



Brusatori
MOTORI ELETTRICI



Brushless servomotors

BR Series

Installation, use and maintenance manual

English version

vers. BR02.01.EN (22-09-2022)

BR

1. Table of contents

1.	Table of contents	3
2.	General	7
2.1	Information	7
2.2	Symbols used.....	8
2.3	Intended use	8
2.4	European directives	9
2.5	Harmonized standards	9
2.6	UL certification	9
3.	Order key	10
4.	Nameplate	12
4.1	Motor nameplate	12
4.2	Nameplate code key	12
5.	Technical data.....	13
5.1	Main features	13
5.2	Available options	14
5.3	Field weakening	14
5.4	Electrical data.....	15
5.4.1	Electrical data BR03.....	15
5.4.2	Electrical data BR05.....	16
5.4.3	Electrical data BR07.....	17
5.4.4	Electrical data BRV7.....	18
5.4.5	Electrical data BR08.....	19
5.4.6	Electrical data BRV8.....	20
5.4.7	Electrical data BR09.....	21
5.4.8	Electrical data BRV9.....	22
5.5	Overall dimensions.....	23
5.5.1	Overall dimensions – BR03.....	23
5.5.2	Overall dimensions – BR05.....	24
5.5.3	Overall dimensions – BR07.....	25
5.5.4	Overall dimensions – BRV7.....	26
5.5.5	Overall dimensions – BR08.....	27
5.5.6	Overall dimensions – BRV8.....	28
5.5.7	Overall dimensions – BR09 (except BR098304)	29
5.5.8	Overall dimensions – BR098304	30
5.5.9	Overall dimensions – BRV9 (except BRV98284)	31
5.5.10	Overall dimensions – BRV98284.....	32
5.6	Characteristic curves torque-speed.....	33
5.6.1	Curves motor series BR03	34
5.6.1.1	Curves BR032 – 230V	34

5.6.1.2	Curves BR032 – 400 V	35
5.6.1.3	Curves BR034 – 230 V	36
5.6.1.4	Curves BR034 – 400 V	37
5.6.1.5	Curves BR036 – 230 V	38
5.6.1.6	Curves BR036 – 400 V	39
5.6.1.7	Curves BR038 – 230 V	40
5.6.1.8	Curves BR038 – 400 V	41
5.6.2	Curves motor series BR05	42
5.6.2.1	Curves BR051 – 400 V	42
5.6.2.2	Curves BR052 – 400 V	43
5.6.2.3	Curves BR053 – 400 V	44
5.6.2.4	Curves BR054 – 400 V	45
5.6.2.5	Curves BR055 – 400 V	46
5.6.2.6	Curves BR056 – 400 V	47
5.6.2.7	Curves BR057 – 400 V	48
5.6.2.8	Curves BR058 – 400 V	49
5.6.3	Curves motor series BR07	50
5.6.3.1	Curves BR071 – 400 V	50
5.6.3.2	Curves BR072 – 400 V	51
5.6.3.3	Curves BR073 – 400 V	52
5.6.3.4	Curves BR074 – 400 V	53
5.6.3.5	Curves BR075 – 400 V	54
5.6.3.6	Curves BR076 – 400 V	55
5.6.3.7	Curves BR077 – 400 V	56
5.6.3.8	Curves BR078 – 400 V	57
5.6.4	Curves motor series BRV7	58
5.6.4.1	Curves BRV71 – 400 V	58
5.6.4.2	Curves BRV72 – 400 V	59
5.6.4.3	Curves BRV73 – 400 V	60
5.6.4.4	Curves BRV74 – 400 V	61
5.6.4.5	Curves BRV75 – 400 V	62
5.6.4.6	Curves BRV76 – 400 V	63
5.6.4.7	Curves BRV77 – 400 V	64
5.6.4.8	Curves BRV78 – 400 V	65
5.6.5	Curves motori serie BR08	66
5.6.5.1	Curves BR082 – 400 V	66
5.6.5.2	Curves BR084 – 400 V	67
5.6.5.3	Curves BR086 – 400 V	68
5.6.5.4	Curves BR088 – 400 V	69
5.6.6	Curves motori serie BRV8	70
5.6.6.1	Curves BRV82 – 400 V	70
5.6.6.2	Curves BRV84 – 400 V	71
5.6.6.3	Curves BRV86 – 400 V	72
5.6.6.4	Curves BRV88 – 400 V	73
5.6.7	Curves motor series BR09	74

5.6.7.1	Curves BR092 – 400 V	74
5.6.7.2	Curves BR094 – 400 V	75
5.6.7.3	Curves BR096 – 400 V	76
5.6.7.4	Curves BR098 – 400 V	77
5.6.8	Curves motor series BRV9	78
5.6.8.1	Curves BRV92 – 400 V	78
5.6.8.2	Curves BRV94 – 400 V	79
5.6.8.3	Curves BRV96 – 400 V	80
5.6.8.4	Curves BRV98 – 400 V	81
6.	Parts and components	82
6.1	Cooling fan (optional)	82
6.1.1	Fan connection diagrams	83
6.2	Holding brake (optional)	84
6.2.1	Brakes: general safety notes	84
6.2.2	Safety and maintenance notes for permanent magnet brakes	85
6.2.3	Permanent magnet brakes	86
6.2.4	Spring brake (emergency brake)	87
6.3	Position sensor.....	88
6.3.1	Transducer operating temperature	88
6.3.2	Resolver (standard).....	88
6.3.3	Encoder SinCos (optional).....	89
6.3.4	Encoder Hiperface (optional).....	89
6.3.5	Encoder EnDat (optional)	89
6.4	Thermal protection	90
6.4.1	Thermistor PTC (standard).....	90
6.4.2	Bimetal switch (optional).....	91
6.4.3	Bimetal switch (optional for ventilation starting).....	91
6.4.4	Thermo-resistance Pt100 or Pt1000 (optional).....	91
6.5	Bearings.....	92
6.6	Maximum radial load on 20000 hours of operation	92
7.	Electrical connections	94
7.1	Instructions on safety	94
7.2	Power connection.....	96
7.2.1	Power connection with connector M23 8 poles (standard)	96
7.2.2	Power connection with connector MIL 4 poles (optional without brake)	96
7.2.3	Power connection with connector MIL 6 poles (optional with brake)	96
7.2.4	Power connection with terminal board (standard / optional)	97
7.3	Signal connection.....	99
7.3.1	Resolver with connector M23 – 12 poles (standard)	100
7.3.2	Resolver with connector MIL series – 19 poles (optional)	100
7.3.3	Encoder SinCos with connector M23 – 17 poles (standard).....	101
7.3.4	Encoder SinCos with connector MIL series – 19 poles (optional).....	101
7.3.5	Encoder Hiperface with connector M23 – 12 poles (standard)	102
7.3.6	Encoder Hiperface with connector MIL series – 19 poles (optional).....	102
7.3.7	Encoder EnDat01 with connector M23 – 17 poles (standard)	103

7.3.8	Encoder EnDat01 with connector MIL series – 19 poles (optional)	103
7.3.9	Encoder EnDat22 with connector M23 – 17 poles (standard)	104
7.3.10	Encoder EnDat22 with connector MIL series – 19 poles (optional)	104
7.3.11	Incremental encoder + Hall sensor and connector M23 – 17 poles (obsolete)	105
7.3.12	Incremental encoder + Hall sensor and connector MIL series – 19 poles (obsolete)	106
7.4	Flying connectors (optional)	107
7.4.1	Flying power connector M23 8 poles (optional)	107
7.4.1.1	Flying power connector 8 poles BSTA078FR05420100000	107
7.4.1.2	Flying power connector 8 poles BSTA078FR35590100000	107
7.4.1.3	Mounting instructions flying power connector BSTA078FR05420100000	108
7.4.1.4	Mounting instructions flying power connector BSTA078FR35590100000	109
7.4.2	Flying power connector 4/6 Poles MIL series (optional)	110
7.4.2.1	Flying power connector MIL 4 poles MS3106PHM211810SA23	110
7.4.2.2	Flying power connector MIL 6 poles MS3106PHM211806SA23	110
7.4.3	Flying signal connector M23 12/17 poles (optional)	111
7.4.3.1	Flying signal connector M23 12 poles ASTA021FS04400166000	111
7.4.3.2	Flying signal connector M23 17 poles ASTA035FS04400166000	111
7.4.3.3	Mounting instructions flying signal connectors M23 12/17 poles	112
7.4.4	Flying signal connector 19P MIL series (optional)	113
7.4.4.1	Flying signal connector MIL 19 poles 62IN16PHM111419S4416	113
8.	Transport and storage	113
8.1	Transport conditions	113
8.2	Storage conditions	113
9.	Installation	114
9.1	Mounting	114
9.2	Commissioning	115
9.3	Balance	116
10.	Operating conditions	117
10.1	Environmental conditions	117
10.2	Derating of the motor in function of temperature / altitude	117
10.3	Safety information	118
11.	Maintenance	119
11.1	Maintenance instructions	119
11.2	Troubleshooting	120
12.	Disposal	121
13.	Certifications	121
13.1	RoHS directive	121
13.2	EMC directive	121
13.3	EU Declaration of Conformity	121
13.4	Quality management system ISO 9001: 2015	121
13.5	UL/CSA Certificate of compliance (optional)	121
14.	Contacts	123

2. General

2.1 Information

WARNING!

All tasks like transport, storage, connection, commissioning and maintenance on the motor must be carried out by qualified personnel, which must be provided with protection equipment, trained for the job and must be familiar with all operations and safety rules.
You must read this manual carefully before any operation.



This manual is available to the user and includes every motor of the Brusatori BR series.

Non-observance of safety instructions can damage people and equipment.

In case of any doubt, uncertainty or miscomprehension, stop any operation immediately and contact our technical department.

Follow national standards and requirements of your country and environment.

WARNING!

Technical specifications of special versions and design variations may differ from motors described in the manual.

If you have any doubt, contact our customer service, providing us type and serial code of the motor.







Brusatori Srl reserves the right to change/adapt specifications and technical data without prior notice.

Special variations agreed with the customer may have priority over the content of this manual.

Machinery's manufacturer must incorporate safety guidelines required for end customers into the operating instructions.

2.2 Symbols used

	DANGER	CAUTION	WARNING
	ELECTRICAL DANGER		
	SUSPENDED LOADS DANGER		
	MAGNETIC FIELDS DANGER		
	HOT SURFACE DANGER		

2.3 Intended use

Electric motors in this manual comply with LOW VOLTAGE DIRECTIVE 2014/35/EU and are intended to be used in standard industrial systems.

They also comply with Directive 2011/65/EU (RoHS) and EMC Directive 2014/30/EU.

Motors are designed and built to be incorporated with other machines or to be assembled with other machinery to make a machine, according to standard MACHINERY DIRECTIVE 2006/42/EC.

If used for other purposes, take the necessary precautions to ensure safety in the intended environment.

WARNING!

Use is prohibited until it has been determined that the machine complies with the provisions of MACHINERY DIRECTIVE 2006/42/EC.

Machinery's manufacturer must also verify that the machine complies with EMC DIRECTIVE 2014/30/EU.



WARNING!

Permanent magnets in the motor can interfere with pacemakers and other devices.

Take the necessary precautions in order to avoid damage to people or things, keeping them distant from the magnets.



This document is intended for the machine's manufacturer, not for the end user.

Machine manufacturer in which the motor will be incorporated must provide to end user proper documentation about installation, use and maintenance.

2.4 European directives

LOW VOLTAGE DIRECTIVE (LVD) 2014/35/EU	Compliance
RoHS DIRECTIVE 2011/65/EU and following Delegated Directives	Compliance
MACHINERY DIRECTIVE 2006/42/EC	Responsibility on machinery's manufacturer
EMC DIRECTIVE 2014/30/EU	Compliance (if equipped with electronic components) Responsibility on machinery's manufacturer

2.5 Harmonized standards

CEI EN 60034-1: 2011	Rotating electrical machines - Part 1: Nominal and operating characteristics
CEI EN 60034-5: 2021	Rotating electrical machines - Part 5: Degree of protection provided by cases of rotating machines (integral project) (IP Code) -Classification
CEI EN 60034-6: 1997	Rotating electrical machines - Part 6: Cooling methods
CEI EN 60034-7: 1997 / A1:2001	Rotating electrical machines - Part 7: Classification of types of constructions and mounting arrangements (IM Code)
CEI EN 60034-8: 2008 / A1:2015	Rotating electrical machines - Part 8: Marking of terminals and rotation sense
CEI EN 60204-1: 2018	Safety of machinery - Electrical equipment of machines - Part 1: General requirements
UL 1446 *	Standard for Systems of Insulating Materials - General
CAN/CSA 22.2 No. 0-M91 Appendix B *	General Requirements - Canadian Electrical Code, Part II
UL 1004-1 *	Rotating Electrical Machines – General Requirements
UL 1004-6 *	Servo and Stepper Motors
CAN/CSA C22.2 No. 100-14 *	Motors and Generators

* Only for UL and CSA certified motors (Optional)

2.6 UL certification

On request	OBJY2/8	Certificated UL/CSA insulation system	File E316823
On request*	PRHZ2/8	UL/CSA certification of the motor	File E526644

* Only for BR 7, BR 8 and BR 9 series.

Only for terminal board or M23 connectors, and permanent magnet brake (if present).

3. Order key

Configuration of a BR series motor is described with the following order key:

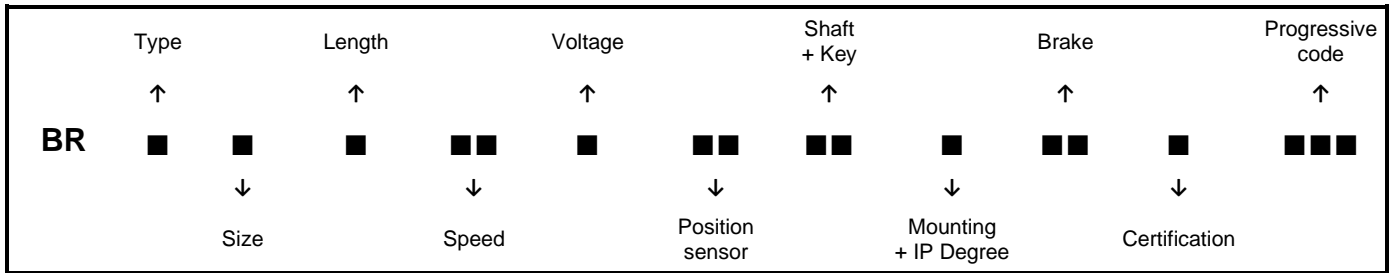





Type		BR■□□□□□□□□□□□□□□□□□□
	0 V	Motor BR0 Motor BRV Without ventilation Air forced ventilation
Size		BR□■□□□□□□□□□□□□□□□□
	3 5 7 8 9	Size 3 Size 5 Size 7 Size 8 Size 9
Length		BR□□■□□□□□□□□□□□□□□
	1 2 3 4 5 6 7 8	Length 1 Length 2 Length 3 Length 4 Length 5 Length 6 Length 7 Length 8
Speed		BR□□□■□□□□□□□□□□□□□□
	10 15 20 28 30 40 60	1000 rpm 1500 rpm 2000 rpm 2800 rpm 3000 rpm 4000 rpm 6000 rpm
Voltage		BR□□□□■□□□□□□□□□□□□□□
	2 4	230 V 400 V
Transducer		BR□□□□□■□□□□□□□□□□□□
	xx	Resolver / Encoder type (Ref. chapter 7.3 of this manual)

Shaft + Key		BR□□□□□□□□■□□□□□□□			
	D1	11x23	with key	Standard	BR 3
	D2	11x23	without key	Optional	BR 3
	E1	14x30	with key	Oversize	BR 3
	E2	14x30	without key	Optional	BR 3
	F1	19x40	with key	Standard	BR 5
	F2	19x40	without key	Optional	BR 5
	G1	24x50	with key	Standard	BR 71÷76
	G2	24x50	without key	Optional	BR 71÷76
	H1	28x60	with key	Standard	BR 77÷78
	H2	28x60	without key	Optional	BR 77÷78
	M3	42x82	with key	Standard	BR 8
	M4	42x82	without key	Optional	BR 8
	N1	48x110	with key	Standard	BR 9
	N2	48x110	without key	Optional	BR 9
Mounting + IP Degree		BR□□□□□□□□□□■□□□□□□□			
	3	B5 + IP 54		Standard	
	4	B5 + IP 65		Optional (with oil seal)	
	5	B35 + IP 54		Optional	
	6	B35 + IP 65		Optional (with oil seal)	
Brake		BR□□□□□□□□□□□□■□□□□□			
	00	No brake			
	xx	Brake type (Ref. chapter 6.2 of this manual)			
Certification		BR□□□□□□□□□□□□□□■□□□□			
	C	CE		Standard	
	I	CE + Insulation system		UL/CSA (OBJY2/8)	
	P	CE + UL/CSA certification		UL/CSA (PRHZ2/8)	
Progressive code		BR□□□□□□□□□□□□□□□□■□■□			
<p>Last 3 digits represent a progressive code, that defines other variants of the motor, such as:</p> <ul style="list-style-type: none"> -Phasing -Power connector -Signal connector -Terminal box position -Cable outlet direction -Thermal protection -Ventilation -Connection diagram -Inertia -Coating -Other customizations... 					

4. Nameplate

Each motor has its own nameplate on it in order to identify it, affixed on the motor as adhesive label. Nominal values and operating conditions are indicated on the plate. Check before commissioning that the values are correct. Plate must be always visible on the motor and the removal is forbidden.

4.1 Motor nameplate

			
Made in Italy BRUSATORI srl I-20012-Cuggiono www.brusatori.eu		S/N A002/001 - yyyy/ww 2020/49 Mat. No.: CUSTOMER CODE	
			
Code 0943042WN1340I001		<i>Brushless Servomotor</i>	
Duty	n_N [rpm]	T₀ [Nm]	T_N [Nm]
S1	3000	175	0
S3 40% 1min	3000	270	150
k_t [Nm/Ams]	1,96	I_{max} [Ams]	168
Feedback: Res. TS2640N1901E64		f [Hz]	200,0
Brake: 24Vdc 225 Nm		J_m [kgcm ²]	482
Cooling: /		Poles 8	ΔT [°C] 105
Thermal sensor: Pt 1000		Ins. Class	
3ph - IEC 60034-1		IM B5 - IC 410 - IP 54	
		Weight [kg]	133,83
 Insulation system CL F(155) Type 155F E316823			

Note:

Appearance of the nameplates in this manual may differ from the real one.

4.2 Nameplate code key

S/N	Motor serial number
yyyy/ww	Year / Week of production
Mat. No.	Customer motor code (if available)
Code	Brusatori motor code
Duty	Duty service
T₀	Stall torque
I₀	Stall current
T_N	Nominal torque
I_N	Nominal current
P_N	Nominal power
n_N	Nominal speed
k_t	Torque constant
I_{max}	Peak current
V_N	Nominal voltage
f	Nominal frequency
J_m	Motor inertia
Poles	Number of poles
ΔT	Overtemperature reference
Ins. class	Windings insulation class
IM	Mounting
IC	Cooling method
IP	Degree of protection
Brake	Brake type
Cooling	Cooling type
Thermal sensor	Thermal protection type
3ph – IEC 60034-1	Number of phases and standard rule
Weight	Motor weight

5. Technical data

5.1 Main features

Windings	Three-phase Y-connection without accessible neutral wire
Windings insulation	Class F
Dimensioning	Class F
Service type	S1 - Continuous
Number of poles	6 (BR 3) 8 (BR 5, 7, 8, 9)
Degree of protection (CEI EN 60034-5)	IP 54
Ambient temperature	-20 to +40 °C Motors without brake +2 to +40 °C Motors with brake
Environmental conditions	Maximum altitude: 1000 m above sea level Humidity: ≤90% (no condensation) Transport / storage temperature: from -20 to +70 °C
Magnetic material	Neodymium-Iron-Boron
Color	RAL 9005 Black
Cooling (CEI EN 60034-6)	IC 410 (no servo-ventilation) IC 416 (servo-ventilation)
Ventilation	Fan starts when supply is connected
Vibration severity (CEI EN 60034-14)	Grade A Half-key balancing
Thermal protection	Thermistor PTC
Type of construction (CEI EN 60034-7)	IM B5 (IM 3001) IM B35 (IM 2001)
Position sensor	Resolver 2 poles
Bearings	Lubricated for life
Running position	Any
Power connection	M23 connector (Series 03, 05, 07) Three-phase terminal board (Series V7, 08, V8, 09, V9)
Signal connection	M23 connector
DC link voltage of the Drive	Designed for values up to 640V Up to 800V if voltage spikes are maintained below 1200V using suitable filters

WARNING!

The motor can only be used for its intended use.
Nominal values and operating conditions are indicated on the nameplate, check before commissioning that the data are correct.



5.2 Available options

Position sensor	Sine-wave encoder Absolute encoder EnDat Absolute encoder Hiperface Other types (after evaluation)
Degree of protection (CEI EN 60034-5)	IP 65 (no servo-ventilation, with oil seal) (*)
Holding brake	Permanent magnet brake (Standard BR 3, 5, 7, 8) Spring brake (Standard BR 9, Optional BR 5, 7, 8)
Thermal protection	Bimetal switch (normally closed) Thermo-resistance Pt100 Thermo-resistance Pt1000
UL/CSA certification	Insulation system UL/CSA (ccn OBJ2/8 - file E316823) Motor certification UL/CSA (ccn PRHZ2/8 - file E526644)
Shaft	Without key Splined According to client's drawing
MIL panel connector	For power and signal
Flying connector	M23 or MIL for power and signal
Oil seal	When needed for coupling in oil bath (*)
Oil exhaust	For direct gearbox coupling (Series 08, V8, 09, V9)
Ventilation	Fan starts when windings temperature reaches 70 °C
Special requirements	On client's request

(*) In case of coupling with gearbox in oil bath, the oil seal must be present, and it is forbidden to put the motor in rotation without oil, in order to avoid damage to the oil seal.

In case of coupling with dry gearbox, or with another flange (without oil), it is possible to remove the oil seal, if installed on the motor, but this decreases the overall protection degree of the motor.

It is suggested to seal the coupling between flange and gearbox (or the other flange), to avoid liquids passing through the shaft.

Manufacturer does not take any responsibility for liquid penetration caused by a damaged or missing oil seal.

5.3 Field weakening

WARNING!

For each motor size to function properly, the converter you use must have a field weakening function.



5.4 Electrical data

5.4.1 Electrical data BR03

BR motor – Without servo-ventilation – 3000 rpm			Drive 3-phase supply 230 Vac				Drive 3-phase supply 400 Vac			
			032302	034302	036302	038302	032304	034304	036304	038304
Stall torque ^{1) 3)}	T ₀	Nm	0.8	1.6	2.4	3	0.8	1.6	2.4	3
Nominal power ¹⁾	P _N	W	201	408	597	723	201	408	597	723
Nominal torque ¹⁾	T _N	Nm	0.64	1.3	1.9	2.3	0.64	1.3	1.9	2.3
Nominal speed	n _N	rpm	3000	3000	3000	3000	3000	3000	3000	3000
Peak torque 20°C	T _{max}	Nm	2.4	4.8	7.2	9	2.4	4.8	7.2	9
Nominal current ¹⁾	I _N	Arms	0.78	1.43	2.15	2.58	0.54	0.88	1.37	1.49
Stall current ^{1) 3)}	I ₀	Arms	0.94	1.7	2.61	3.25	0.65	1.05	1.66	1.87
Peak current	I _{max}	Arms	2.75	4.95	7.61	9.46	1.9	3.05	4.85	5.46
Rotor inertia	J _m	kgcm ²	0.4	0.75	1.1	1.45	0.4	0.75	1.1	1.45
Voltage constant 20°C ²⁾	k _e	Vs/rad	0.53	0.59	0.57	0.58	0.77	0.95	0.90	1.00
Torque constant 20°C with stall rotor ²⁾	k _t	Nm/Arms	0.89	0.99	0.97	0.97	1.29	1.6	1.51	1.68
Ke and kt reduction coeff. over temperature	dk/dt	[%/°C]	-0.11	-0.11	-0.11	-0.11	-0.11	-0.11	-0.11	-0.11
Winding resistance 20°C ²⁾	R _c	Ohm	23.7	9.34	4.8	3.3	49	24.1	12	10
Winding inductance ²⁾	L _c	mH	53	24	14	6.3	160	67	40	18
E.M.F at 1000 rpm 20°C ²⁾	V1000	V/krpm	55.5	61.7	60.2	60.5	80.2	100	94.4	105
Nominal voltage ¹⁾	V _N	V _{rms}	181	191	182	180	266	309	287	312
Weight	m	kg	2.3	3.3	4.3	5.3	2.3	3.3	4.3	5.3
Number of poles	2p		6	6	6	6	6	6	6	6

BR motor – Without servo-ventilation – 4000 rpm			Drive 3-phase supply 230 Vac				Drive 3-phase supply 400 Vac			
			032402	034402	036402	038402	032404	034404	036404	038404
Stall torque ^{1) 3)}	T ₀	Nm	0.8	1.6	2.4	3	0.8	1.6	2.4	3
Nominal power ¹⁾	P _N	W	268	545	796	963	268	545	796	963
Nominal torque ¹⁾	T _N	Nm	0.64	1.3	1.9	2.3	0.64	1.3	1.9	2.3
Nominal speed	n _N	rpm	4000	4000	4000	4000	4000	4000	4000	4000
Peak torque 20°C	T _{max}	Nm	2.4	4.8	7.2	9	2.4	4.8	7.2	9
Nominal current ¹⁾	I _N	Arms	1.08	1.91	2.79	3.33	0.68	1.15	1.64	1.95
Stall current ^{1) 3)}	I ₀	Arms	1.3	2.26	3.39	4.19	0.82	1.36	2	2.45
Peak current	I _{max}	Arms	3.78	6.59	9.89	12.2	2.38	3.96	5.82	7.13
Rotor inertia	J _m	kgcm ²	0.4	0.75	1.1	1.45	0.4	0.75	1.1	1.45
Voltage constant 20°C ²⁾	k _e	Vs/rad	0.39	0.44	0.44	0.45	0.61	0.74	0.75	0.77
Torque constant 20°C with stall rotor ²⁾	k _t	Nm/Arms	0.65	0.74	0.74	0.75	1.03	1.24	1.26	1.29
Ke and kt reduction coeff. over temperature	dk/dt	[%/°C]	-0.11	-0.11	-0.11	-0.11	-0.11	-0.11	-0.11	-0.11
Winding resistance 20°C ²⁾	R _c	Ohm	12.3	5.2	2.82	1.97	30.6	14.8	8.42	5.73
Winding inductance ²⁾	L _c	mH	30	14	8.3	3.7	80	36	24	11
E.M.F at 1000 rpm 20°C ²⁾	V1000	V/krpm	40.4	46.3	46.3	46.9	64.2	77.1	78.7	80.2
Nominal voltage ¹⁾	V _N	V _{rms}	170	187	184	183	271	311	313	313
Weight	m	kg	2.3	3.3	4.3	5.3	2.3	3.3	4.3	5.3
Number of poles	2p		6	6	6	6	6	6	6	6

BR motor – Without servo-ventilation – 6000 rpm			Drive 3-phase supply 230 Vac				Drive 3-phase supply 400 Vac			
			032602	034602	036602	038602	032604	034604	036604	038604
Stall torque ^{1) 3)}	T ₀	Nm	0.8	1.6	2.4	3	0.8	1.6	2.4	3
Nominal power ¹⁾	P _N	W	402	817	1194	1445	402	817	1194	1445
Nominal torque ¹⁾	T _N	Nm	0.64	1.3	1.9	2.3	0.64	1.3	1.9	2.3
Nominal speed	n _N	rpm	6000	6000	6000	6000	6000	6000	6000	6000
Peak torque 20°C	T _{max}	Nm	2.4	4.8	7.2	9	2.4	4.8	7.2	9
Nominal current ¹⁾	I _N	Arms	1.62	2.98	4.23	5.28	0.88	1.68	2.49	2.94
Stall current ^{1) 3)}	I ₀	Arms	1.95	3.54	5.14	6.63	1.06	2	3.03	3.7
Peak current	I _{max}	Arms	5.68	10.3	15	19.3	3.09	5.82	8.83	10.8
Rotor inertia	J _m	kgcm ²	0.4	0.75	1.1	1.45	0.4	0.75	1.1	1.45
Voltage constant 20°C ²⁾	k _e	Vs/rad	0.26	0.28	0.29	0.28	0.47	0.50	0.49	0.51
Torque constant 20°C with stall rotor ²⁾	k _t	Nm/Arms	0.43	0.48	0.49	0.48	0.79	0.84	0.83	0.85
Ke and kt reduction coeff. over temperature	dk/dt	[%/°C]	-0.11	-0.11	-0.11	-0.11	-0.11	-0.11	-0.11	-0.11
Winding resistance 20°C ²⁾	R _c	Ohm	5.42	2.17	1.26	0.78	18.9	6.86	3.7	2.5
Winding inductance ²⁾	L _c	mH	13.3	6	3.6	1.52	42	19	12	5.4
E.M.F at 1000 rpm 20°C ²⁾	V1000	V/krpm	26.8	29.6	30.5	29.6	49.4	52.4	51.8	53.1
Nominal voltage ¹⁾	V _N	V _{rms}	164	176	179	171	302	311	304	328
Weight	m	kg	2.3	3.3	4.3	5.3	2.3	3.3	4.3	5.3
Number of poles	2p		6	6	6	6	6	6	6	6

Torque and power values refer to motor flanged and suspended in horizontal positions (aluminium flange 200x250x25 mm)

Minimum PWM 8kHz, DC bus test voltage 590 Vdc, tested with resolver

¹⁾ Continuous service S1 (dT=105°C)

²⁾ Tolerance ± 10%

³⁾ Value referred to 100 rpm

5.4.2 Electrical data BR05

BR motor – Without servo-ventilation – 2000 rpm			051204	052204	053204	054204	055204	056204	057204	058204
Stall torque ¹⁾³⁾	T ₀	Nm	2	4	5.4	6.9	8.2	9.3	10.4	11.5
Nominal power ¹⁾	P _N	W	377	775	1047	1319	1529	1717	1864	2011
Nominal torque ¹⁾	T _N	Nm	1.8	3.7	5	6.3	7.3	8.2	8.9	9.6
Nominal speed	n _N	rpm	2000	2000	2000	2000	2000	2000	2000	2000
Peak torque 20°C	T _{max}	Nm	6	12	16.2	20.7	24.6	27.9	31.2	34.5
Nominal current ¹⁾	I _N	Arms	0.81	1.57	2.23	2.76	3.15	3.69	3.88	4.32
Stall current ¹⁾³⁾	I ₀	Arms	0.87	1.64	2.32	2.92	3.41	4.03	4.37	4.99
Peak current	I _{max}	Arms	2.53	4.78	6.76	8.5	9.95	11.8	12.7	14.5
Rotor inertia	J _m	kgcm ²	1.25	2	2.8	3.5	4.25	5	5.8	6.5
Voltage constant 20°C ²⁾	k _e	Vs/rad	1.44	1.52	1.46	1.48	1.50	1.44	1.49	1.44
Torque constant 20°C with stall rotor ²⁾	k _t	Nm/Arms	2.42	2.56	2.45	2.48	2.52	2.42	2.5	2.42
Ke and kt reduction coeff. over temperature	dk/dt	[%/°C]	-0.11	-0.11	-0.11	-0.11	-0.11	-0.11	-0.11	-0.11
Winding resistance 20°C ²⁾	R _c	Ohm	84.3	28.7	15.5	9.77	7.73	5.51	4.88	3.9
Winding inductance ²⁾	L _c	mH	192	92.9	48.3	34.6	31.8	23.1	21.6	16
E.M.F at 1000 rpm 20°C ²⁾	V1000	V/krpm	151	160	152	155	157	151	156	151
Nominal voltage ¹⁾	V _n	Vrms	381	368	335	328	330	312	319	306
Weight	m	kg	4.2	5.1	6	6.9	7.8	8.7	9.6	10.5
Number of poles	2p		8	8	8	8	8	8	8	8

BR motor – Without servo-ventilation – 3000 rpm			051304	052304	053304	054304	055304	056304	057304	058304
Stall torque ¹⁾³⁾	T ₀	Nm	2	4	5.4	6.9	8.2	9.3	10.4	11.5
Nominal power ¹⁾	P _N	W	550	1131	1508	1885	2136	2356	2513	2670
Nominal torque ¹⁾	T _N	Nm	1.75	3.6	4.8	6	6.8	7.5	8	8.5
Nominal speed	n _N	rpm	3000	3000	3000	3000	3000	3000	3000	3000
Peak torque 20°C	T _{max}	Nm	6	12	16.2	20.7	24.6	27.9	31.2	34.5
Nominal current ¹⁾	I _N	Arms	1.26	2.38	3.16	3.9	4.44	5.02	5.35	5.53
Stall current ¹⁾³⁾	I ₀	Arms	1.39	2.55	3.43	4.32	5.16	5.99	6.7	7.2
Peak current	I _{max}	Arms	4.04	7.44	9.99	12.6	15	17.5	19.5	21
Rotor inertia	J _m	kgcm ²	1.25	2	2.8	3.5	4.25	5	5.8	6.5
Voltage constant 20°C ²⁾	k _e	Vs/rad	0.90	0.98	0.98	1.00	0.99	0.97	0.97	1.00
Torque constant 20°C with stall rotor ²⁾	k _t	Nm/Arms	1.51	1.65	1.65	1.68	1.67	1.63	1.63	1.68
Ke and kt reduction coeff. over temperature	dk/dt	[%/°C]	-0.11	-0.11	-0.11	-0.11	-0.11	-0.11	-0.11	-0.11
Winding resistance 20°C ²⁾	R _c	Ohm	32.7	12.3	6.71	4.67	3.37	2.52	2.06	1.87
Winding inductance ²⁾	L _c	mH	70.7	36.9	21.2	17.6	14.1	9.9	9.2	7.7
E.M.F at 1000 rpm 20°C ²⁾	V1000	V/krpm	94.3	103	103	105	104	102	102	105
Nominal voltage ¹⁾	V _n	Vrms	328	336	322	323	316	304	302	308
Weight	m	kg	4.2	5.1	6	6.9	7.8	8.7	9.6	10.5
Number of poles	2p		8	8	8	8	8	8	8	8

BR motor – Without servo-ventilation – 4000 rpm			051404	052404	053404	054404	055404	056404	057404	058404
Stall torque ¹⁾³⁾	T ₀	Nm	2	4	5.4	6.9	8.2	9.3	10.4	11.5
Nominal power ¹⁾	P _N	W	712	1466	1927	2346	2597	2806	2932	3142
Nominal torque ¹⁾	T _N	Nm	1.7	3.5	4.6	5.6	6.2	6.7	7	7.5
Nominal speed	n _N	rpm	4000	4000	4000	4000	4000	4000	4000	4000
Peak torque 20°C	T _{max}	Nm	6	12	16.2	20.7	24.6	27.9	31.2	34.5
Nominal current ¹⁾	I _N	Arms	1.52	3.03	4.06	4.91	5.44	5.81	6.11	6.58
Stall current ¹⁾³⁾	I ₀	Arms	1.72	3.34	4.59	5.83	6.93	7.77	8.74	9.72
Peak current	I _{max}	Arms	5.02	9.73	13.4	17	20.2	22.6	25.5	28.3
Rotor inertia	J _m	kgcm ²	1.25	2	2.8	3.5	4.25	5	5.8	6.5
Voltage constant 20°C ²⁾	k _e	Vs/rad	0.73	0.75	0.73	0.74	0.74	0.75	0.74	0.74
Torque constant 20°C with stall rotor ²⁾	k _t	Nm/Arms	1.22	1.26	1.23	1.24	1.24	1.26	1.25	1.24
Ke and kt reduction coeff. over temperature	dk/dt	[%/°C]	-0.11	-0.11	-0.11	-0.11	-0.11	-0.11	-0.11	-0.11
Winding resistance 20°C ²⁾	R _c	Ohm	20.8	7.03	3.7	2.58	1.84	1.53	1.24	1.02
Winding inductance ²⁾	L _c	mH	48.5	21.4	13.3	10	7.7	5.9	5.4	4.2
E.M.F at 1000 rpm 20°C ²⁾	V1000	V/krpm	76	78.4	76.9	77.4	77.4	78.4	77.9	77.4
Nominal voltage ¹⁾	V _n	Vrms	339	331	314	312	306	307	303	320
Weight	m	kg	4.2	5.1	6	6.9	7.8	8.7	9.6	10.5
Number of poles	2p		8	8	8	8	8	8	8	8

Torque and power values refer to motor flanged and suspended in horizontal positions (aluminium flange 350x350x25 mm)

Minimum PWM 8kHz, DC bus test voltage 590 Vdc, tested with resolver

¹⁾ Continuous service S1 (dT=105°C)

²⁾ Tolerance ± 10%

³⁾ Value referred to 100 rpm

5.4.3 Electrical data BR07

BR motor – Without servo-ventilation – 1500 rpm			071154	072154	073154	074154	075154	076154	077154	078154
Stall torque ¹⁾³⁾	T ₀	Nm	5.8	11.6	17.5	22	25.5	30	34.2	38.7
Nominal power ¹⁾	P _N	W	880	1602	2592	3220	3770	4320	4791	5262
Nominal torque ¹⁾	T _N	Nm	5.6	10.2	16.5	20.5	24	27.5	30.5	33.5
Nominal speed	n _N	rpm	1500	1500	1500	1500	1500	1500	1500	1500
Peak torque 20°C	T _{max}	Nm	13.2	25.9	37.7	48.3	63.0	74.4	87.9	100
Nominal current ¹⁾	I _N	Arms	1.9	3.4	5.3	6.4	7.8	8.8	9.9	10.8
Stall current ¹⁾³⁾	I ₀	Arms	1.9	3.7	5.5	6.6	8.0	9.2	10.7	12.0
Peak current	I _{max}	Arms	4.5	8.6	12.1	14.9	20.3	23.6	28.2	32.0
Rotor inertia	J _m	kgcm ²	5.23	8.52	11.82	15.10	18.40	21.69	24.98	28.27
Voltage constant 20°C ²⁾	k _e	Vs/rad	1.90	1.94	2.00	2.08	1.99	2.03	2.00	2.01
Torque constant 20°C with stall rotor ²⁾	k _t	Nm/Arms	3.19	3.26	3.36	3.49	3.35	3.41	3.36	3.38
Ke and kt reduction coeff. over temperature	dk/dt	[%/°C]	-0.11	-0.11	-0.11	-0.11	-0.11	-0.11	-0.11	-0.11
Winding resistance 20°C ²⁾	R _c	Ohm	23.58	8.02	4.635	3.4	2.34	1.93	1.59	1.37
Winding inductance ²⁾	L _c	mH	88.3	50.2	32.3	26.4	18.76	15.5	13.3	10.7
E.M.F at 1000 rpm 20°C ²⁾	V1000	V/krpm	199	203	210	218	209	212	210	210
Nominal voltage ¹⁾	V _n	Vrms	345	330	336	343	323	326	320	318
Weight	m	kg	9.5	11.9	14.2	16.6	18.9	21.3	23.6	26
Number of poles	2p		8	8	8	8	8	8	8	8

BR motor – Without servo-ventilation – 2000 rpm			071204	072204	073204	074204	075204	076204	077204	078204
Stall torque ¹⁾³⁾	T ₀	Nm	5.8	11.6	17.5	22	25.5	30	34.2	38.7
Nominal power ¹⁾	P _N	W	1152	2094	3351	4189	4880	5362	5843	6367
Nominal torque ¹⁾	T _N	Nm	5.5	10	16	20	23.3	25.6	27.9	30.4
Nominal speed	n _N	rpm	2000	2000	2000	2000	2000	2000	2000	2000
Peak torque 20°C	T _{max}	Nm	12.7	25.6	38.6	50.0	61.1	75.9	88.0	100
Nominal current ¹⁾	I _N	Arms	2.4	4.4	7.0	8.5	9.7	11.0	11.9	12.9
Stall current ¹⁾³⁾	I ₀	Arms	2.4	4.9	7.4	9.0	10.2	12.4	14.1	15.9
Peak current	I _{max}	Arms	5.5	11.0	16.7	21.1	25.2	32.4	37.3	42.2
Rotor inertia	J _m	kgcm ²	5.23	8.52	11.82	15.10	18.40	21.69	24.98	28.27
Voltage constant 20°C ²⁾	k _e	Vs/rad	1.50	1.49	1.48	1.52	1.56	1.51	1.52	1.52
Torque constant 20°C with stall rotor ²⁾	k _t	Nm/Arms	2.52	2.50	2.49	2.56	2.62	2.53	2.55	2.56
Ke and kt reduction coeff. over temperature	dk/dt	[%/°C]	-0.11	-0.11	-0.11	-0.11	-0.11	-0.11	-0.11	-0.11
Winding resistance 20°C ²⁾	R _c	Ohm	14.72	4.6	2.55	1.83	1.43	1.07	0.905	0.782
Winding inductance ²⁾	L _c	mH	58	29.3	18.14	14.2	10.96	9.3	7.81	5.86
E.M.F at 1000 rpm 20°C ²⁾	V1000	V/krpm	157	156	155	160	163	158	159	160
Nominal voltage ¹⁾	V _n	Vrms	349	328	324	328	330	317	316	314
Weight	m	kg	9.5	11.9	14.2	16.6	18.9	21.3	23.6	26
Number of poles	2p		8	8	8	8	8	8	8	8

BR motor – Without servo-ventilation – 3000 rpm			071304	072304	073304	074304	075304	076304	077304	078304
Stall torque ¹⁾³⁾	T ₀	Nm	5.8	11.6	17.5	22	25.5	30	34.2	38.7
Nominal power ¹⁾	P _N	W	1696	3079	4430	5184	5812	6283	6692	6974
Nominal torque ¹⁾	T _N	Nm	5.4	9.8	14.1	16.5	18.5	20	21.3	22.2
Nominal speed	n _N	rpm	3000	3000	3000	3000	3000	3000	3000	3000
Peak torque 20°C	T _{max}	Nm	12.4	25.4	37.5	50.0	62.5	75.0	88.2	100
Nominal current ¹⁾	I _N	Arms	3.3	6.2	8.8	10.3	11.5	12.5	13.4	13.9
Stall current ¹⁾³⁾	I ₀	Arms	3.5	7.2	10.6	13.4	15.5	18.2	20.9	23.5
Peak current	I _{max}	Arms	7.6	16.0	23.2	30.9	38.6	46.4	55.0	61.8
Rotor inertia	J _m	kgcm ²	5.23	8.52	11.82	15.10	18.40	21.69	24.98	28.27
Voltage constant 20°C ²⁾	k _e	Vs/rad	1.05	1.02	1.04	1.04	1.04	1.04	1.03	1.04
Torque constant 20°C with stall rotor ²⁾	k _t	Nm/Arms	1.76	1.72	1.75	1.75	1.75	1.75	1.73	1.75
Ke and kt reduction coeff. over temperature	dk/dt	[%/°C]	-0.11	-0.11	-0.11	-0.11	-0.11	-0.11	-0.11	-0.11
Winding resistance 20°C ²⁾	R _c	Ohm	7.25	2.19	1.26	0.849	0.65	0.515	0.419	0.361
Winding inductance ²⁾	L _c	mH	30.23	12.4	9.23	6.39	4.78	4.09	3.09	2.94
E.M.F at 1000 rpm 20°C ²⁾	V1000	V/krpm	110	107	109	109	109	109	108	109
Nominal voltage ¹⁾	V _n	Vrms	356	326	329	322	319	317	311	313
Weight	m	kg	9.5	11.9	14.2	16.6	18.9	21.3	23.6	26
Number of poles	2p		8	8	8	8	8	8	8	8

Torque and power values refer to motor flanged and suspended in horizontal positions (steel flange 500x500x40 mm)

Minimum PWM 8kHz, DC bus test voltage ≤ 560 Vdc uncontrolled, tested with resolver

¹⁾ Continuous service S1 (dT=105°C)

²⁾ Tolerance ± 10%

³⁾ Value referred to 100 rpm

5.4.4 Electrical data BRV7

BR motor – With servo-ventilation – 1500 rpm			V71154	V72154	V73154	V74154	V75154	V76154	V77154	V78154
Stall torque ¹⁾³⁾	T ₀	Nm	8.1	15.4	23.0	31.0	37.0	42.0	48.0	54.0
Nominal power ¹⁾	P _N	W	1166	2296	3456	4555	5341	6126	6959	7697
Nominal torque ¹⁾	T _N	Nm	7.4	14.6	22.0	29.0	34.0	39.0	44.3	49.0
Nominal speed	n _N	rpm	1500	1500	1500	1500	1500	1500	1500	1500
Peak torque 20°C	T _{max}	Nm	15.9	31.1	45.2	58.0	75.7	89.2	105.5	120
Nominal current ¹⁾	I _N	Arms	2.5	4.9	7.1	9.0	11.1	12.5	14.4	15.8
Stall current ¹⁾³⁾	I ₀	Arms	2.7	5.0	7.2	9.3	11.6	12.9	15.0	16.8
Peak current	I _{max}	Arms	5.4	10.3	14.5	17.9	24.4	28.3	33.9	38.4
Rotor inertia	J _m	kgcm ²	5.2	8.5	11.8	15.1	18.4	21.7	25.0	28.3
Voltage constant 20°C ²⁾	k _e	Vs/rad	1.90	1.94	2.00	2.08	1.99	2.03	2.00	2.01
Torque constant 20°C with stall rotor ²⁾	k _t	Nm/Arms	3.19	3.26	3.36	3.49	3.35	3.41	3.36	3.38
Ke and kt reduction coeff. over temperature	dk/dt	[%/°C]	-0.11	-0.11	-0.11	-0.11	-0.11	-0.11	-0.11	-0.11
Winding resistance 20°C ²⁾	R _c	Ohm	23.58	8.02	4.635	3.4	2.34	1.93	1.59	1.37
Winding inductance ²⁾	L _c	mH	88.3	50.2	32.3	26.4	18.76	15.5	13.3	10.7
E.M.F at 1000 rpm 20°C ²⁾	V1000	V/krpm	199	203	210	218	209	212	210	210
Nominal voltage ¹⁾	V _N	Vrms	371	357	356	365	342	342	337	333
Weight	m	kg	11.5	14	16.7	19.1	21.9	24.3	27.1	29.5
Number of poles	2p		8	8	8	8	8	8	8	8

BR motor – With servo-ventilation – 2000 rpm			V71204	V72204	V73204	V74204	V75204	V76204	V77204	V78204
Stall torque ¹⁾³⁾	T ₀	Nm	8.1	15.4	23.0	31.0	37.0	42.0	48.0	54.0
Nominal power ¹⁾	P _N	W	1466	2932	4503	5864	6807	7854	8796	9844
Nominal torque ¹⁾	T _N	Nm	7.0	14.0	21.5	28.0	32.5	37.5	42.0	47.0
Nominal speed	n _N	rpm	2000	2000	2000	2000	2000	2000	2000	2000
Peak torque 20°C	T _{max}	Nm	15.3	30.7	46.3	60.0	73.3	91.0	105.6	120
Nominal current ¹⁾	I _N	Arms	3.0	6.1	9.4	11.9	13.5	16.1	18.0	20.0
Stall current ¹⁾³⁾	I ₀	Arms	3.4	6.5	9.7	12.7	14.8	17.4	19.8	22.1
Peak current	I _{max}	Arms	6.5	13.2	20.1	25.3	30.2	38.8	44.8	50.6
Rotor inertia	J _m	kgcm ²	5.2	8.5	11.8	15.1	18.4	21.7	25.0	28.3
Voltage constant 20°C ²⁾	k _e	Vs/rad	1.50	1.49	1.48	1.52	1.56	1.51	1.52	1.52
Torque constant 20°C with stall rotor ²⁾	k _t	Nm/Arms	2.52	2.50	2.49	2.56	2.62	2.53	2.55	2.56
Ke and kt reduction coeff. over temperature	dk/dt	[%/°C]	-0.11	-0.11	-0.11	-0.11	-0.11	-0.11	-0.11	-0.11
Winding resistance 20°C ²⁾	R _c	Ohm	14.72	4.6	2.55	1.83	1.43	1.07	0.905	0.782
Winding inductance ²⁾	L _c	mH	58	29.3	18.14	14.2	10.96	9.3	7.81	5.86
E.M.F at 1000 rpm 20°C ²⁾	V1000	V/krpm	157	156	155	160	163	158	159	160
Nominal voltage ¹⁾	V _N	Vrms	369	349	341	346	345	333	331	327
Weight	m	kg	11.5	14	16.7	19.1	21.9	24.3	27.1	29.5
Number of poles	2p		8	8	8	8	8	8	8	8

BR motor – With servo-ventilation – 3000 rpm			V71304	V72304	V73304	V74304	V75304	V76304	V77304	V78304
Stall torque ¹⁾³⁾	T ₀	Nm	8.1	15.4	23.0	31.0	37.0	42.0	48.0	54.0
Nominal power ¹⁾	P _N	W	1979	3958	6126	7540	8954	10367	11310	12252
Nominal torque ¹⁾	T _N	Nm	6.3	12.6	19.5	24.0	28.5	33.0	36.0	39.0
Nominal speed	n _N	rpm	3000	3000	3000	3000	3000	3000	3000	3000
Peak torque 20°C	T _{max}	Nm	14.9	30.5	45.0	60.0	75.0	90.0	105.9	120.0
Nominal current ¹⁾	I _N	Arms	3.9	8.0	12.2	15.0	17.8	20.6	22.7	24.3
Stall current ¹⁾³⁾	I ₀	Arms	4.8	9.4	13.8	18.6	22.2	25.3	29.1	32.5
Peak current	I _{max}	Arms	9.1	19.2	27.8	37.1	46.4	55.7	66.0	74.2
Rotor inertia	J _m	kgcm ²	5.2	8.5	11.8	15.1	18.4	21.7	25.0	28.3
Voltage constant 20°C ²⁾	k _e	Vs/rad	1.05	1.02	1.04	1.04	1.04	1.04	1.03	1.04
Torque constant 20°C with stall rotor ²⁾	k _t	Nm/Arms	1.76	1.72	1.75	1.75	1.75	1.75	1.73	1.75
Ke and kt reduction coeff. over temperature	dk/dt	[%/°C]	-0.11	-0.11	-0.11	-0.11	-0.11	-0.11	-0.11	-0.11
Winding resistance 20°C ²⁾	R _c	Ohm	7.25	2.19	1.26	0.849	0.65	0.515	0.419	0.361
Winding inductance ²⁾	L _c	mH	30.23	12.4	9.23	6.39	4.78	4.09	3.09	2.94
E.M.F at 1000 rpm 20°C ²⁾	V1000	V/krpm	110	107	109	109	109	109	108	109
Nominal voltage ¹⁾	V _N	Vrms	364	338	345	336	331	330	322	324
Weight	m	kg	11.5	14	16.7	19.1	21.9	24.3	27.1	29.5
Number of poles	2p		8	8	8	8	8	8	8	8

Torque and power values refer to motor flanged and suspended in horizontal positions (steel flange 500x500x40 mm)

Minimum PWM 8kHz, DC bus test voltage ≤ 560 Vdc uncontrolled, tested with resolver

¹⁾ Continuous service S1 (dT=105°C)

²⁾ Tolerance ± 10%

³⁾ Value referred to 100 rpm

5.4.5 Electrical data BR08

BR motor – Without servo-ventilation – 1000 rpm			082104	084104	086104	088104
Stall torque ¹⁾³⁾	T ₀	Nm	32.5	60	82	102
Nominal power ¹⁾	P _N	W	3299	5864	7540	9425
Nominal torque ¹⁾	T _N	Nm	31.5	56	72	90
Nominal speed	n _N	rpm	1000	1000	1000	1000
Peak torque 20°C	T _{max}	Nm	88	165	239	290
Nominal current ¹⁾	I _N	Arms	6.7	13.1	15.3	19.7
Stall current ¹⁾³⁾	I ₀	Arms	6.72	13.6	17	21.7
Peak current	I _{max}	Arms	18.4	37.9	49.9	62.4
Rotor inertia	J _m	kgcm ²	49	89	128	167
Voltage constant 20°C ²⁾	k _e	Vs/rad	2.99	2.72	2.99	2.9
Torque constant 20°C with stall rotor ²⁾	k _t	Nm/Arms	5.03	4.57	5.03	4.88
Ke and kt reduction coeff. over temperature	dk/dt	[%/°C]	0.89	2.89	4.89	-0.11
Winding resistance 20°C ²⁾	R _c	Ohm	4.86	1.34	0.9	0.62
Winding inductance ²⁾	L _c	mH	47.8	19.8	15.9	11.2
E.M.F at 1000 rpm 20°C ²⁾	V1000	V/krpm	314	285	314	304
Nominal voltage ¹⁾	V _n	Vrms	351	302	321	308
Weight	m	kg	30	43	54	68
Number of poles	2p		8	8	8	8

BR motor – Without servo-ventilation – 2000 rpm			082204	084204	086204	088204
Stall torque ¹⁾³⁾	T ₀	Nm	32.5	60	82	102
Nominal power ¹⁾	P _N	W	6388	10681	12985	15980
Nominal torque ¹⁾	T _N	Nm	30.5	51	62	76.3
Nominal speed	n _N	rpm	2000	2000	2000	2000
Peak torque 20°C	T _{max}	Nm	88	165	239	290
Nominal current ¹⁾	I _N	Arms	14.3	22.4	29	33.5
Stall current ¹⁾³⁾	I ₀	Arms	14.8	25.6	37.3	43.5
Peak current	I _{max}	Arms	40.4	71	110	125
Rotor inertia	J _m	kgcm ²	49	89	128	167
Voltage constant 20°C ²⁾	k _e	Vs/rad	1.36	1.45	1.36	1.45
Torque constant 20°C with stall rotor ²⁾	k _t	Nm/Arms	2.29	2.44	2.29	2.44
Ke and kt reduction coeff. over temperature	dk/dt	[%/°C]	-0.11	-0.11	-0.11	-0.11
Winding resistance 20°C ²⁾	R _c	Ohm	0.95	0.39	0.19	0.16
Winding inductance ²⁾	L _c	mH	9.9	5.6	3.3	2.81
E.M.F at 1000 rpm 20°C ²⁾	V1000	V/krpm	143	152	143	152
Nominal voltage ¹⁾	V _n	Vrms	300	307	281	297
Weight	m	kg	30	43	54	68
Number of poles	2p		8	8	8	8

BR motor – Without servo-ventilation – 3000 rpm			082304	084304	086304	088304
Stall torque ¹⁾³⁾	T ₀	Nm	32.5	60	82	102
Nominal power ¹⁾	P _N	W	9268	13823	16650	20420
Nominal torque ¹⁾	T _N	Nm	29.5	44	53	65
Nominal speed	n _N	rpm	3000	3000	3000	3000
Peak torque 20°C	T _{max}	Nm	88	165	239	290
Nominal current ¹⁾	I _N	Arms	18.8	30.9	31	38
Stall current ¹⁾³⁾	I ₀	Arms	20.2	40.9	46.6	58
Peak current	I _{max}	Arms	55.1	114	137	166
Rotor inertia	J _m	kgcm ²	49	89	128	167
Voltage constant 20°C ²⁾	k _e	Vs/rad	1.00	0.91	1.09	1.09
Torque constant 20°C with stall rotor ²⁾	k _t	Nm/Arms	1.68	1.52	1.83	1.83
Ke and kt reduction coeff. over temperature	dk/dt	[%/°C]	-0.11	-0.11	-0.11	-0.11
Winding resistance 20°C ²⁾	R _c	Ohm	0.49	0.15	0.13	0.09
Winding inductance ²⁾	L _c	mH	5.3	2.19	2.11	1.58
E.M.F at 1000 rpm 20°C ²⁾	V1000	V/krpm	105	95	114	114
Nominal voltage ¹⁾	V _n	Vrms	322	281	331	329
Weight	m	kg	30	43	54	68
Number of poles	2p		8	8	8	8

Torque and power values refer to motor flanged and suspended in horizontal positions (steel flange 500x500x40 mm)

Minimum PWM 8kHz, DC bus test voltage ≤ 560 Vdc uncontrolled, tested with resolver

¹⁾ Continuous service S1 (dT=105°C)

²⁾ Tolerance ± 10%

³⁾ Value referred to 100 rpm

5.4.6 Electrical data BRV8

BR motor – With servo-ventilation – 1000 rpm			V82104	V84104	V86104	V88104
Stall torque ¹⁾³⁾	T ₀	Nm	45	89	130	163
Nominal power ¹⁾	P _N	W	4472	9111	12985	16127
Nominal torque ¹⁾	T _N	Nm	42.7	87	124	154
Nominal speed	n _N	rpm	1000	1000	1000	1000
Peak torque 20°C	T _{max}	Nm	100	218	300	400
Nominal current ¹⁾	I _N	Arms	9.08	20.4	26.4	33.8
Stall current ¹⁾³⁾	I ₀	Arms	9.3	20.2	26.9	34.7
Peak current	I _{max}	Arms	21.9	52.4	65.6	90.2
Rotor inertia	J _m	kgcm ²	49	89	128	167
Voltage constant 20°C ²⁾	k _e	Vs/rad	2.99	2.72	2.99	2.9
Torque constant 20°C with stall rotor ²⁾	k _t	Nm/Arms	5.03	4.57	5.03	4.88
Ke and kt reduction coeff. over temperature	dk/dt	[%/°C]	-0.11	-0.11	-0.11	-0.11
Winding resistance 20°C ²⁾	R _c	Ohm	4.86	1.34	0.9	0.62
Winding inductance ²⁾	L _c	mH	47.8	19.8	15.9	11.2
E.M.F at 1000 rpm 20°C ²⁾	V1000	V/krpm	314	285	314	304
Nominal voltage ¹⁾	V _n	Vrms	380	332	355	338
Weight	m	kg	37	49	64	78
Number of poles	2p		8	8	8	8

BR motor – With servo-ventilation – 2000 rpm			V82204	V84204	V86204	V88204
Stall torque ¹⁾³⁾	T ₀	Nm	45	89	130	163
Nominal power ¹⁾	P _N	W	8796	17802	24714	30159
Nominal torque ¹⁾	T _N	Nm	42	85	118	144
Nominal speed	n _N	rpm	2000	2000	2000	2000
Peak torque 20°C	T _{max}	Nm	100	218	300	400
Nominal current ¹⁾	I _N	Arms	19.7	37.3	55.2	63.2
Stall current ¹⁾³⁾	I ₀	Arms	20.5	37.9	59.1	69.5
Peak current	I _{max}	Arms	48.1	98.3	144	180
Rotor inertia	J _m	kgcm ²	49	89	128	167
Voltage constant 20°C ²⁾	k _e	Vs/rad	1.36	1.45	1.36	1.45
Torque constant 20°C with stall rotor ²⁾	k _t	Nm/Arms	2.29	2.44	2.29	2.44
Ke and kt reduction coeff. over temperature	dk/dt	[%/°C]	-0.11	-0.11	-0.11	-0.11
Winding resistance 20°C ²⁾	R _c	Ohm	0.95	0.39	0.19	0.16
Winding inductance ²⁾	L _c	mH	9.9	5.6	3.3	2.81
E.M.F at 1000 rpm 20°C ²⁾	V1000	V/krpm	143	152	143	152
Nominal voltage ¹⁾	V _n	Vrms	321	336	308	322
Weight	m	kg	37	49	64	78
Number of poles	2p		8	8	8	8

BR motor – With servo-ventilation – 3000 rpm			V82304	V84304	V86304	V88304
Stall torque ¹⁾³⁾	T ₀	Nm	45	89	130	163
Nominal power ¹⁾	P _N	W	13509	25133	34872	43040
Nominal torque ¹⁾	T _N	Nm	43	80	111	137
Nominal speed	n _N	rpm	3000	3000	3000	3000
Peak torque 20°C	T _{max}	Nm	100	218	300	400
Nominal current ¹⁾	I _N	Arms	27.4	56.1	64.9	80.1
Stall current ¹⁾³⁾	I ₀	Arms	27.9	60.7	73.9	92.7
Peak current	I _{max}	Arms	65.6	157	180	241
Rotor inertia	J _m	kgcm ²	49	89	128	167
Voltage constant 20°C ²⁾	k _e	Vs/rad	1.00	0.91	1.09	1.09
Torque constant 20°C with stall rotor ²⁾	k _t	Nm/Arms	1.68	1.52	1.83	1.83
Ke and kt reduction coeff. over temperature	dk/dt	[%/°C]	-0.11	-0.11	-0.11	-0.11
Winding resistance 20°C ²⁾	R _c	Ohm	0.49	0.15	0.13	0.09
Winding inductance ²⁾	L _c	mH	5.3	2.19	2.11	1.49
E.M.F at 1000 rpm 20°C ²⁾	V1000	V/krpm	105	95	114	114
Nominal voltage ¹⁾	V _n	Vrms	346	306	360	351
Weight	m	kg	37	49	64	78
Number of poles	2p		8	8	8	8

Torque and power values refer to motor flanged and suspended in horizontal positions (steel flange 500x500x40 mm)

Minimum PWM 8kHz, DC bus test voltage ≤ 560 Vdc uncontrolled, tested with resolver

¹⁾ Continuous service S1 (dT=105°C)

²⁾ Tolerance ± 10%

³⁾ Value referred to 100 rpm

5.4.7 Electrical data BR09

BR motor – Without servo-ventilation – 1000 rpm			092104	094104	096104	098104
Stall torque ¹⁾³⁾ () ⁵⁾	T ₀	Nm	100 (153)	182 (270)	270 (400)	340 (493)
Nominal power ¹⁾ () ⁵⁾	P _N	W	9739 (14870)	15708 (24086)	21468 (33510)	28274 (38746)
Nominal torque ¹⁾ () ⁵⁾	T _N	Nm	93 (142)	150 (230)	205 (320)	270 (370)
Nominal speed	n _N	rpm	1000	1000	1000	1000
Peak torque 20°C	T _{max}	Nm	168	295	440	530
Nominal current ¹⁾ () ⁵⁾	I _N	Arms	21.6 (33)	32.7 (50.1)	47.6 (74.3)	58.8 (80.6)
Stall current ¹⁾³⁾ () ⁴⁾	I ₀	Arms	21.6 (33)	36.8 (54.7)	58.3 (86.4)	68.8 (99.8)
Peak current	I _{max}	Arms	38.3	63.1	100	113
Rotor inertia	J _m	kgcm ²	224	401	577	753
Voltage constant 20°C ²⁾	k _e	Vs/rad	2.92	3.12	2.92	3.12
Torque constant 20°C with stall rotor ²⁾	k _t	Nm/Arms	4.91	5.24	4.91	5.24
Ke and kt reduction coeff. over temperature	dk/dt	[%/°C]	-0.11	-0.11	-0.11	-0.11
Winding resistance 20°C ²⁾	R _c	Ohm	0.826	0.312	0.155	0.115
Winding inductance ²⁾	L _c	mH	13.21	6.50	4.41	4.26
E.M.F at 1000 rpm 20°C ²⁾	V1000	V/krpm	306	326	306	326
Nominal voltage ¹⁾ () ⁵⁾	V _n	Vrms	323 (355)	325 (344)	303 (321)	325 (339)
Weight	m	kg	75	109	143	177
Number of poles	2p		8	8	8	8

BR motor – Without servo-ventilation – 2000 rpm			092204	094204	096204	098204
Stall torque ¹⁾³⁾ () ⁵⁾	T ₀	Nm	100 (151)	182 (270)	270 (440)	340 (493)
Nominal power ¹⁾ () ⁵⁾	P _N	W	15917 (27227)	23667 (43982)	24086 (69115)	27227 (71628)
Nominal torque ¹⁾ () ⁵⁾	T _N	Nm	76 (130)	113 (210)	115 (330)	130 (342)
Nominal speed	n _N	rpm	2000	2000 ⁴⁾	2000 ⁴⁾	2000
Peak torque 20°C	T _{max}	Nm	168	295	440	530
Nominal current ¹⁾ () ⁵⁾	I _N	Arms	33.1 (56.6)	49.2 (91.4)	44.5 (128)	56.6 (149)
Stall current ¹⁾³⁾ () ⁴⁾	I ₀	Arms	40.5 (61.1)	73.7 (109)	97.2 (158)	138 (200)
Peak current	I _{max}	Arms	71.9	126	167	227
Rotor inertia	J _m	kgcm ²	224	401	577	753
Voltage constant 20°C ²⁾	k _e	Vs/rad	1.56	1.56	1.75	1.56
Torque constant 20°C with stall rotor ²⁾	k _t	Nm/Arms	2.62	2.62	2.95	2.62
Ke and kt reduction coeff. over temperature	dk/dt	[%/°C]	-0.11	-0.11	-0.11	-0.11
Winding resistance 20°C ²⁾	R _c	Ohm	0.23	0.07	0.05	0.03
Winding inductance ²⁾	L _c	mH	4.40	1.20	0.80	0.60
E.M.F at 1000 rpm 20°C ²⁾	V1000	V/krpm	163	163	184	163
Nominal voltage ¹⁾ () ⁵⁾	V _n	Vrms	330 (367)	311 (321)	345 (357)	326 (315)
Weight	m	kg	75	109	143	177
Number of poles	2p		8	8	8	8

BR motor – Without servo-ventilation – 3000 rpm			092304	094304	096304	098304
Stall torque ¹⁾³⁾ () ⁵⁾	T ₀	Nm	100 (151)	182 (270)	270 (400)	340 (493)
Nominal power ¹⁾ () ⁵⁾	P _N	W	18850 (29217)	14137 (47124)	0 (70686)	0 (76969)
Nominal torque ¹⁾ () ⁵⁾	T _N	Nm	60 (93)	45 (150)	0 (225)	0 (245)
Nominal speed	n _N	rpm	3000 ⁴⁾	3000 ⁴⁾	3000 ⁴⁾	3000 ⁴⁾
Peak torque 20°C	T _{max}	Nm	168	295	440	530
Nominal current ¹⁾ () ⁵⁾	I _N	Arms	34.8 (54)	26.1 (87.1)	0 (131)	0 (142)
Stall current ¹⁾³⁾ () ⁴⁾	I ₀	Arms	54 (81.5)	98 (146)	143 (216)	184 (266)
Peak current	I _{max}	Arms	95.8	168	251	302
Rotor inertia	J _m	kgcm ²	224	401	577	753
Voltage constant 20°C ²⁾	k _e	Vs/rad	1.17	1.17	1.17	1.17
Torque constant 20°C with stall rotor ²⁾	k _t	Nm/Arms	1.96	1.96	1.96	1.96
Ke and kt reduction coeff. over temperature	dk/dt	[%/°C]	-0.11	-0.11	-0.11	-0.11
Winding resistance 20°C ²⁾	R _c	Ohm	0.12	0.04	0.02	0.02
Winding inductance ²⁾	L _c	mH	2.40	1.20	0.80	0.60
E.M.F at 1000 rpm 20°C ²⁾	V1000	V/krpm	122	122	122	122
Nominal voltage ¹⁾ () ⁵⁾	V _n	Vrms	358 (377)	344 (364)	341 (363)	341 (356)
Weight	m	kg	75	109	143	177
Number of poles	2p		8	8	8	8

Torque and power values refer to motor flanged and suspended in horizontal positions (steel flange 500x500x40 mm)

Minimum PWM 4kHz, DC bus test voltage ≤ 560 Vdc uncontrolled, tested with resolver

¹⁾ Continuous service S1 (dT=105°C)

²⁾ Tolerance ± 10%

³⁾ Value referred to 100 rpm

⁴⁾ Inverters connected to these motors must have a field weakening option in order to reach nominal speed

⁵⁾ Duty S3 - 40% - 1 minute

5.4.8 Electrical data BRV9

BR motor – With servo-ventilation – 1000 rpm			V92104	V94104	V96104	V98104
Stall torque ¹⁾³⁾	T ₀	Nm	145	310	440	580
Nominal power ¹⁾	P _N	W	14975	30369	41364	55501
Nominal torque ¹⁾	T _N	Nm	143	290	395	530
Nominal speed	n _N	rpm	1000 ⁴⁾	1000 ⁴⁾	1000	1000 ⁴⁾
Peak torque 20°C	T _{max}	Nm	305	620	840	1100
Nominal current ¹⁾	I _N	Arms	33.2	63.1	91.7	115.4
Stall current ¹⁾³⁾	I ₀	Arms	31.3	62.8	95.0	117.4
Peak current	I _{max}	Arms	69	133	192	235
Rotor inertia	J _m	kgcm ²	224	401	577	753
Voltage constant 20°C ²⁾	k _e	Vs/rad	2.92	3.12	2.92	3.12
Torque constant 20°C with stall rotor ²⁾	k _t	Nm/Arms	4.91	5.24	4.91	5.24
Ke and kt reduction coeff. over temperature	dk/dt	[%/°C]	-0.11	-0.11	-0.11	-0.11
Winding resistance 20°C ²⁾	R _c	Ohm	0.83	0.31	0.16	0.12
Winding inductance ²⁾	L _c	mH	13.21	6.5	4.41	4.26
E.M.F at 1000 rpm 20°C ²⁾	V1000	V/krpm	306	326	306	326
Nominal voltage ¹⁾	V _n	Vrms	356	360	336	366
Weight	m	kg	89	126	164	203
Number of poles	2p		8	8	8	8

BR motor – With servo-ventilation – 2000 rpm			V92204	V94204	V96204	V98204
Stall torque ¹⁾³⁾	T ₀	Nm	145	310	440	580
Nominal power ¹⁾	P _N	W	26180	54454	73304	98437
Nominal torque ¹⁾	T _N	Nm	125	260	350	470
Nominal speed	n _N	rpm	2000 ⁴⁾	2000 ⁴⁾	2000 ⁴⁾	2000 ⁴⁾
Peak torque 20°C	T _{max}	Nm	305	620	840	950
Nominal current ¹⁾	I _N	Arms	54.4	110.2	135.5	204.7
Stall current ¹⁾³⁾	I ₀	Arms	58.7	127.3	158.3	239.3
Peak current	I _{max}	Arms	130	265	319	406
Rotor inertia	J _m	kgcm ²	224	401	577	753
Voltage constant 20°C ²⁾	k _e	Vs/rad	1.56	1.56	1.75	1.56
Torque constant 20°C with stall rotor ²⁾	k _t	Nm/Arms	2.62	2.62	2.95	2.62
Ke and kt reduction coeff. over temperature	dk/dt	[%/°C]	-0.11	-0.11	-0.11	-0.11
Winding resistance 20°C ²⁾	R _c	Ohm	0.23	0.07	0.049	0.027
Winding inductance ²⁾	L _c	mH	4.4	2.13	1.7	1.06
E.M.F at 1000 rpm 20°C ²⁾	V1000	V/krpm	163	163	184	163
Nominal voltage ¹⁾	V _n	Vrms	363	356	387	348
Weight	m	kg	89	126	164	203
Number of poles	2p		8	8	8	8

BR motor – With servo-ventilation – 2800 rpm			V92284	V94284	V96284	V98284
Stall torque ¹⁾³⁾	T ₀	Nm	145	300	440	580
Nominal power ¹⁾	P _N	W	34306	67440	87965	93829
Nominal torque ¹⁾	T _N	Nm	117	230	300	320
Nominal speed	n _N	rpm	2800 ⁴⁾	2800 ⁴⁾	2800 ⁴⁾	2800 ⁴⁾
Peak torque 20°C	T _{max}	Nm	305	600	750	880
Nominal current ¹⁾	I _N	Arms	67.9	133.5	174.2	185.8
Stall current ¹⁾³⁾	I ₀	Arms	78.3	161.9	237.5	313.1
Peak current	I _{max}	Arms	174	342	428	502
Rotor inertia	J _m	kgcm ²	224	401	577	753
Voltage constant 20°C ²⁾	k _e	Vs/rad	1.17	1.17	1.17	1.17
Torque constant 20°C with stall rotor ²⁾	k _t	Nm/Arms	1.96	1.96	1.96	1.96
Ke and kt reduction coeff. over temperature	dk/dt	[%/°C]	-0.11	-0.11	-0.11	-0.11
Winding resistance 20°C ²⁾	R _c	Ohm	0.12	0.038	0.022	0.015
Winding inductance ²⁾	L _c	mH	2.4	1.2	0.8	0.6
E.M.F at 1000 rpm 20°C ²⁾	V1000	V/krpm	122	122	122	122
Nominal voltage ¹⁾	V _n	Vrms	368	363	353	341
Weight	m	kg	89	126	164	203
Number of poles	2p		8	8	8	8

Torque and power values refer to motor flanged and suspended in horizontal positions (steel flange 500x500x40 mm)

Minimum PWM 4kHz, DC bus test voltage ≤ 560 Vdc uncontrolled, tested with resolver

¹⁾ Continuous service S1 (dT=105°C)

²⁾ Tolerance ± 10%

³⁾ Value referred to 100 rpm

⁴⁾ Inverters connected to these motors must have a field weakening option in order to reach nominal speed

5.5 Overall dimensions

5.5.1 Overall dimensions – BR03

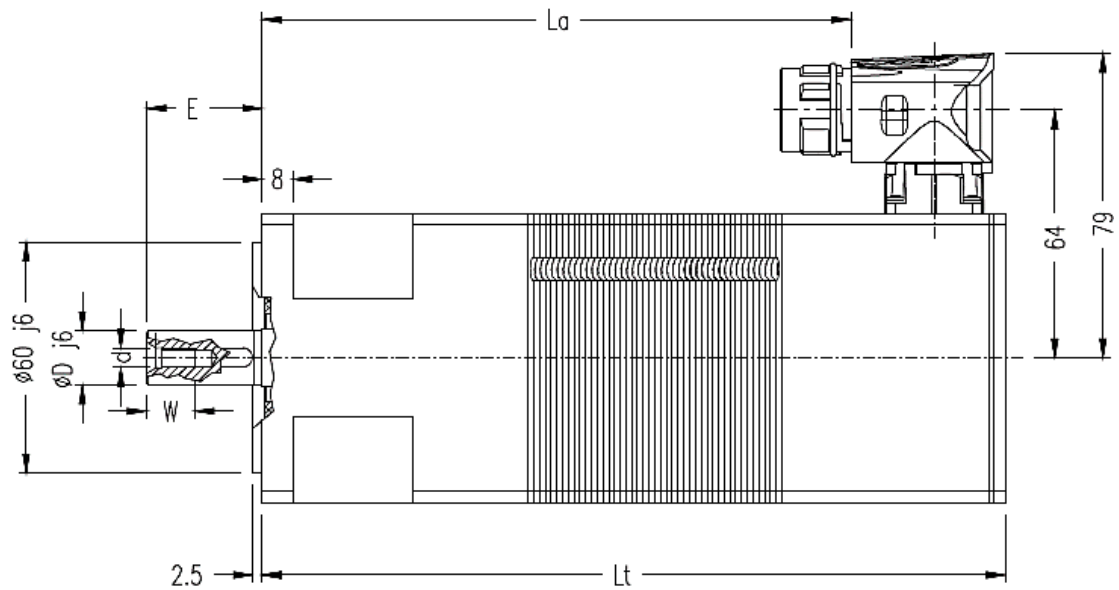

VENTILATION: FREE CONVECTION IC410

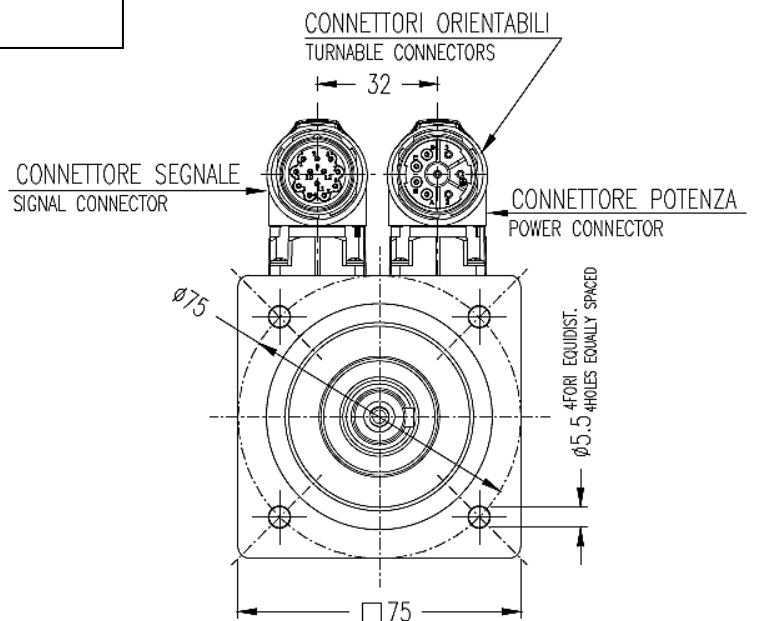
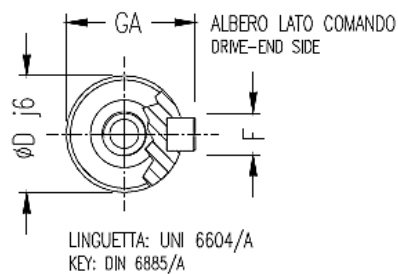

With and without brake - Shaft <i>Standard / (Oversize)</i>							
	Lt	La	ØD J6	E	d x W	F	GA
BR032	151	111	11 (14)	23 (30)	M4x10 (M5x12.5)	4 (5)	12.5 (16)
BR034	172	132					
BR036	193	153					
BR038	214	174					

5.5.2 Overall dimensions – BR05

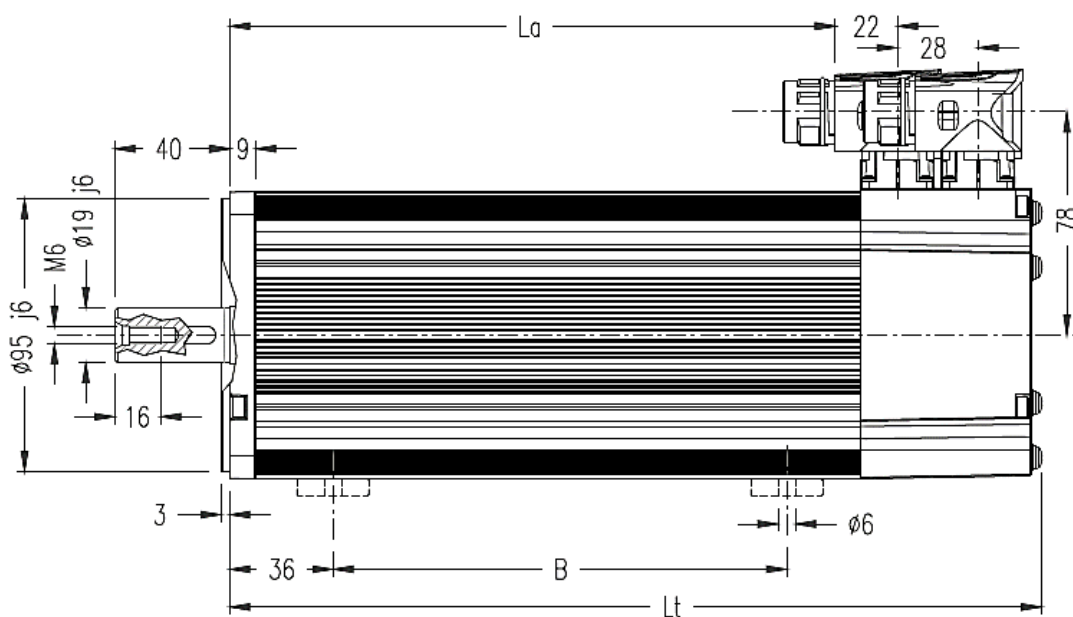

VENTILATION: FREE CONVECTION IC410

	Without brake		
	B	La	Lt
BR051	50	102	176
BR052	72	124	198
BR053	94	146	220
BR054	115	167	241
BR055	137	189	265
BR056	158	210	284
BR057	180	232	306
BR058	202	252	328

	With brake		
	B	La	Lt
BR051	90	142	216
BR052	112	164	238
BR053	134	186	260
BR054	155	207	281
BR055	177	229	305
BR056	198	250	324
BR057	220	272	346
BR058	242	292	368

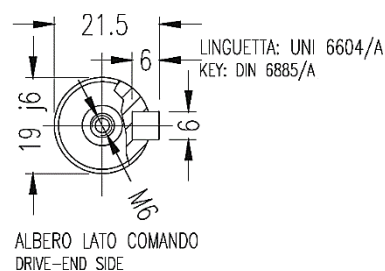
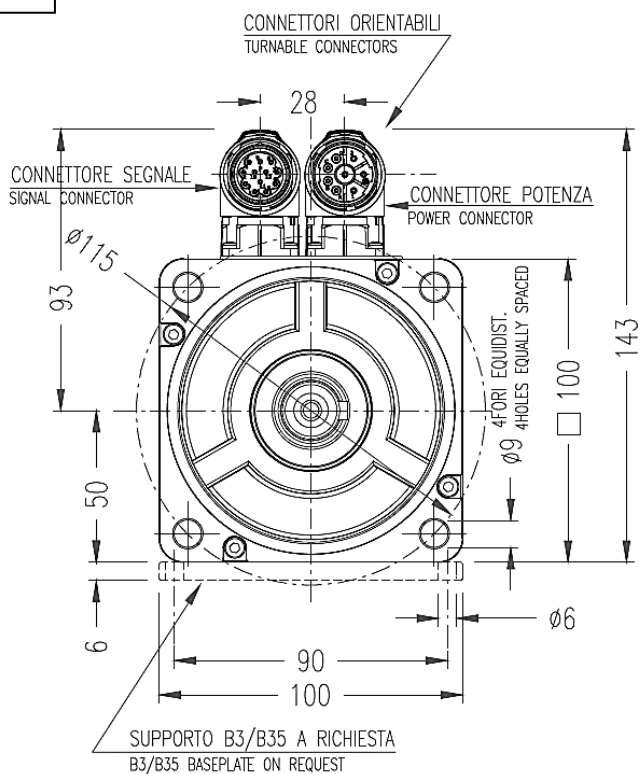

5.5.3 Overall dimensions – BR07

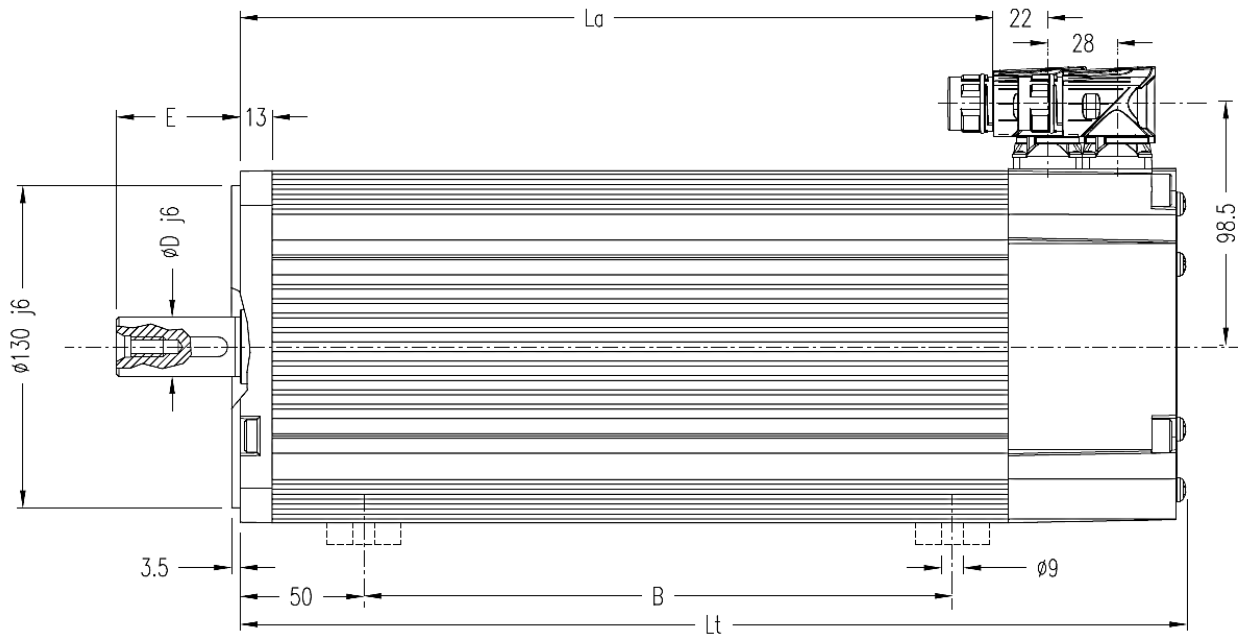

VENTILATION: FREE CONVECTION IC410

	Without brake			ØDxE
	B	La	Lt	
BR071	73	138	217	24x50
BR072	100	166	245	
BR073	128	194	273	
BR074	155	221	300	
BR075	183	249	328	
BR076	210	276	355	
BR077	238	304	383	28x60
BR078	265	331	410	

	With brake			ØDxE
	B	La	Lt	
BR071	123	188	267	24x50
BR072	150	216	295	
BR073	178	244	323	
BR074	205	271	350	
BR075	233	299	378	
BR076	260	326	405	
BR077	288	354	433	28x60
BR078	315	381	460	

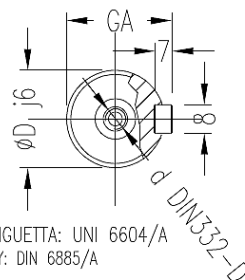
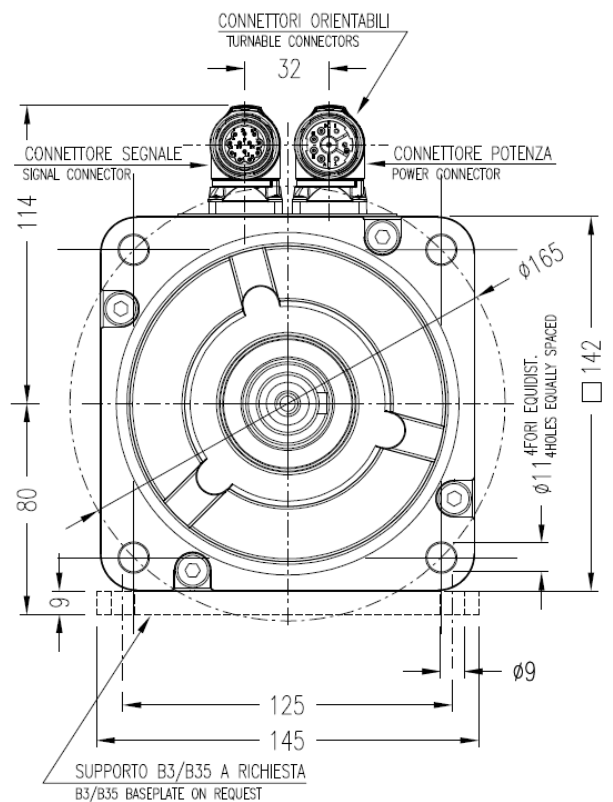

ØDxE	24x50	28x60
GA	27	31
d	M8	M10

5.5.4 Overall dimensions – BRV7

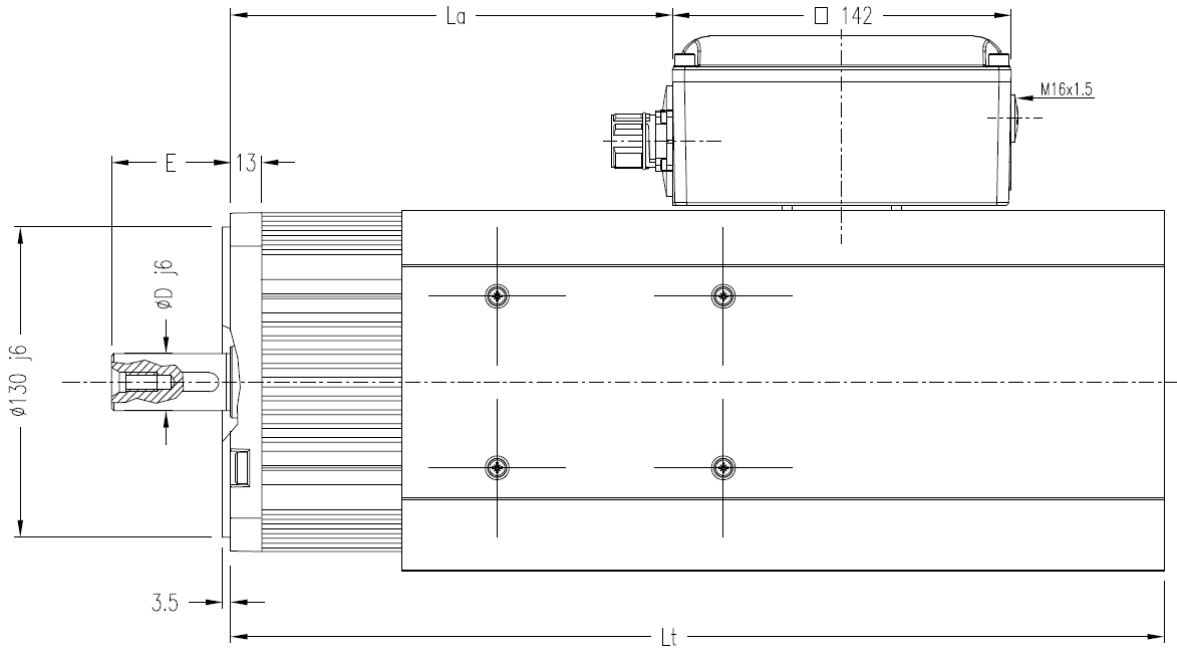

VENTILATION: FORCED CONVECTION IC416

	Without brake		
	La	Lt	ØDxE
BRV71	102	312	24x50
BRV72	130	340	
BRV73	158	368	
BRV74	185	395	
BRV75	213	423	
BRV76	240	450	28x60
BRV77	268	478	
BRV78	295	505	

	With brake		
	La	Lt	ØDxE
BRV71	152	362	24x50
BRV72	180	390	
BRV73	208	418	
BRV74	235	445	
BRV75	263	473	
BRV76	290	500	28x60
BRV77	318	528	
BRV78	345	555	

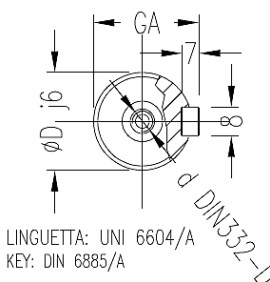
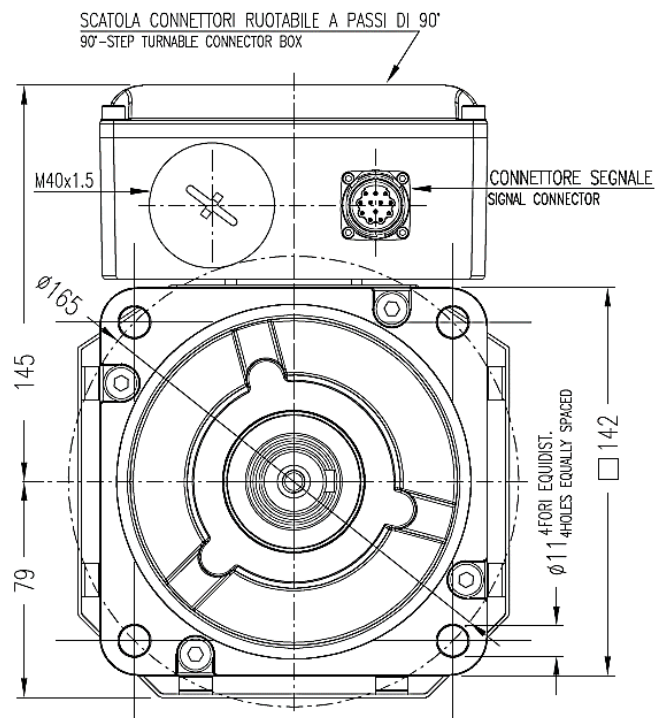

ØDxE	24x50	28x60
GA	27	31
d	M8	M10

5.5.5 Overall dimensions – BR08

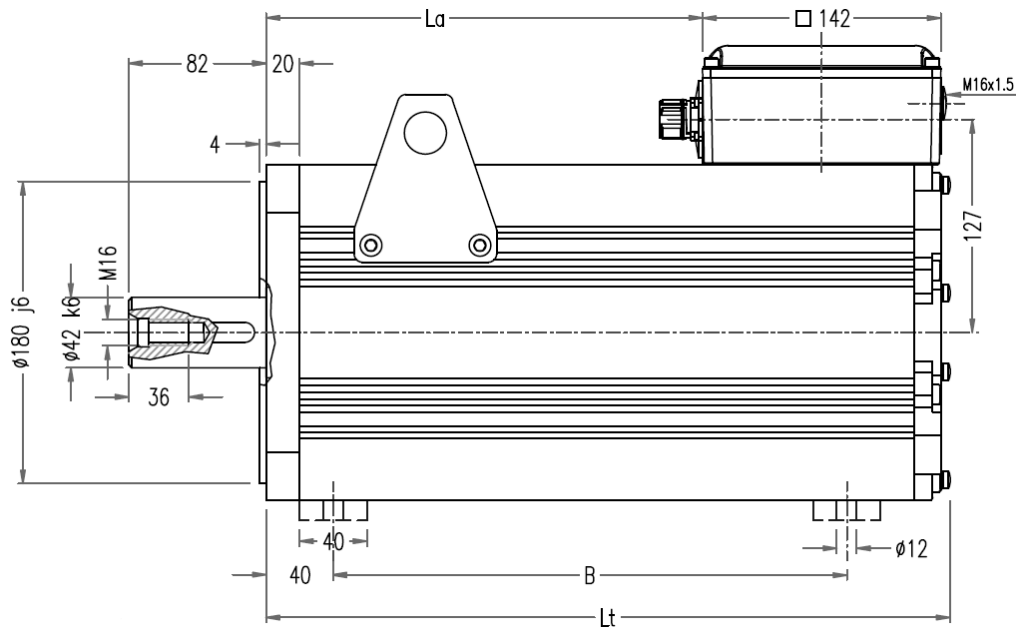

VENTILATION: FREE CONVECTION IC410

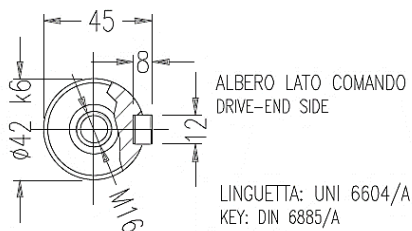

	Without brake		
	B	La	Lt
BR082	156	110	259
BR084	231	185	333
BR086	306	260	408
BR088	380	334	483

	With brake		
	B	La	Lt
BR082	276	230	379
BR084	351	305	453
BR086	426	380	528
BR088	500	454	603

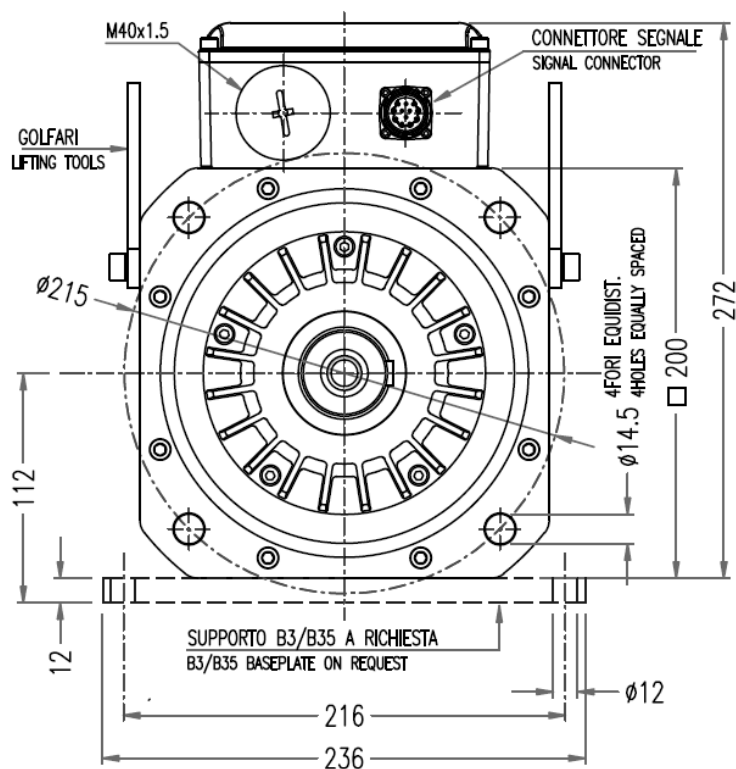

5.5.6 Overall dimensions – BRV8

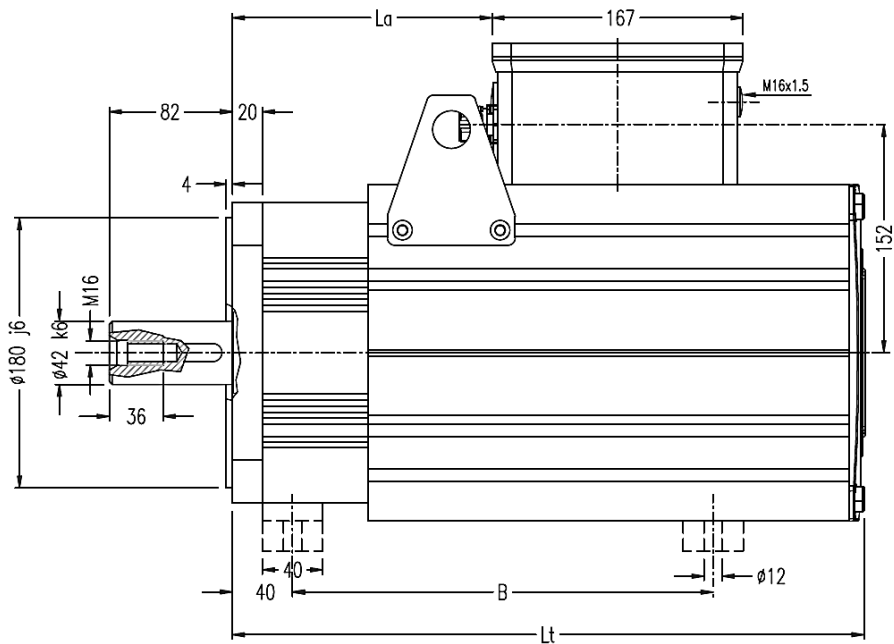

VENTILATION: FORCED CONVECTION IC416

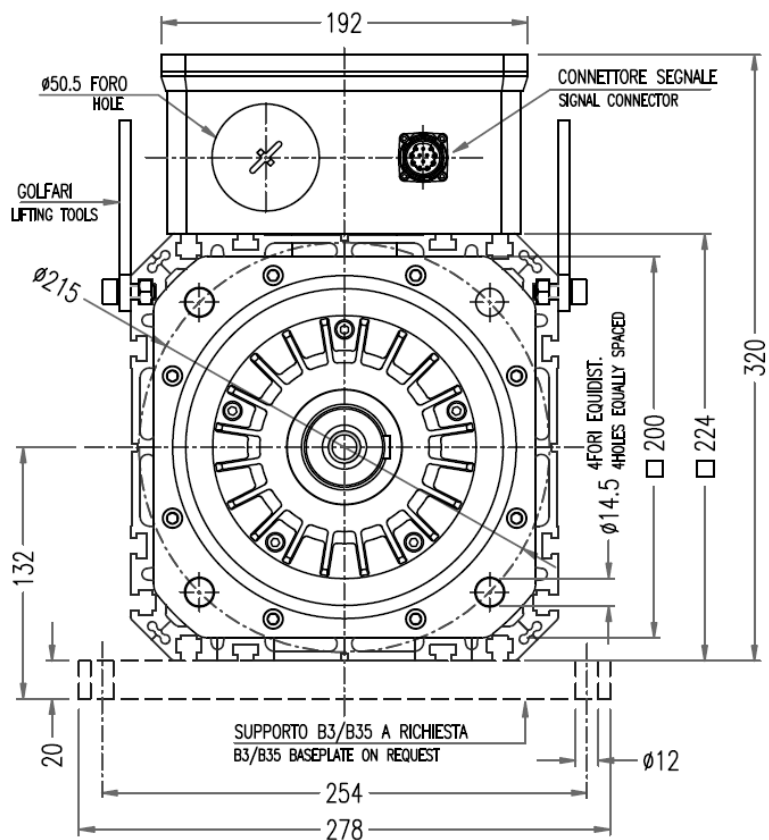
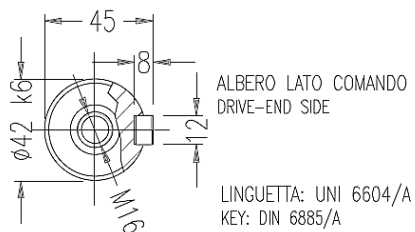

	Without brake		
	B	La	Lt
BRV82	205	98	353
BRV84	280	173	428
BRV86	354	248	502
BRV88	429	323	577

	With brake		
	B	La	Lt
BRV82	325	218	473
BRV84	400	293	548
BRV86	474	368	622
BRV88	549	443	697

5.5.7 Overall dimensions – BR09 (except BR098304)

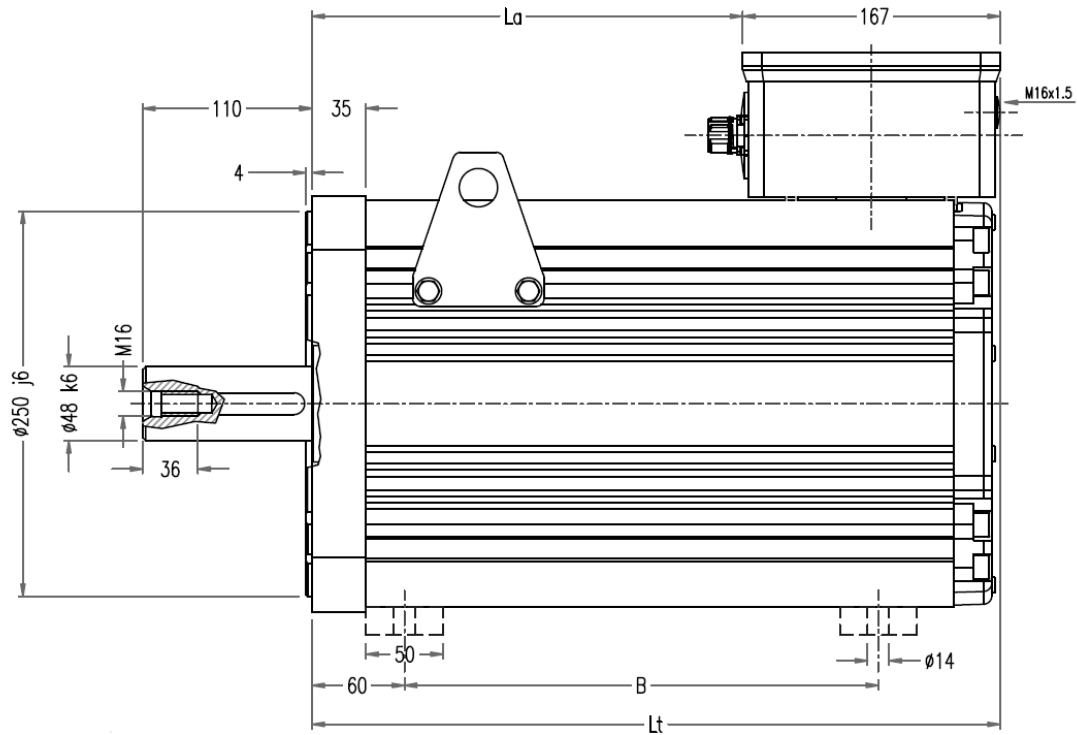

VENTILATION: FREE CONVECTION IC410

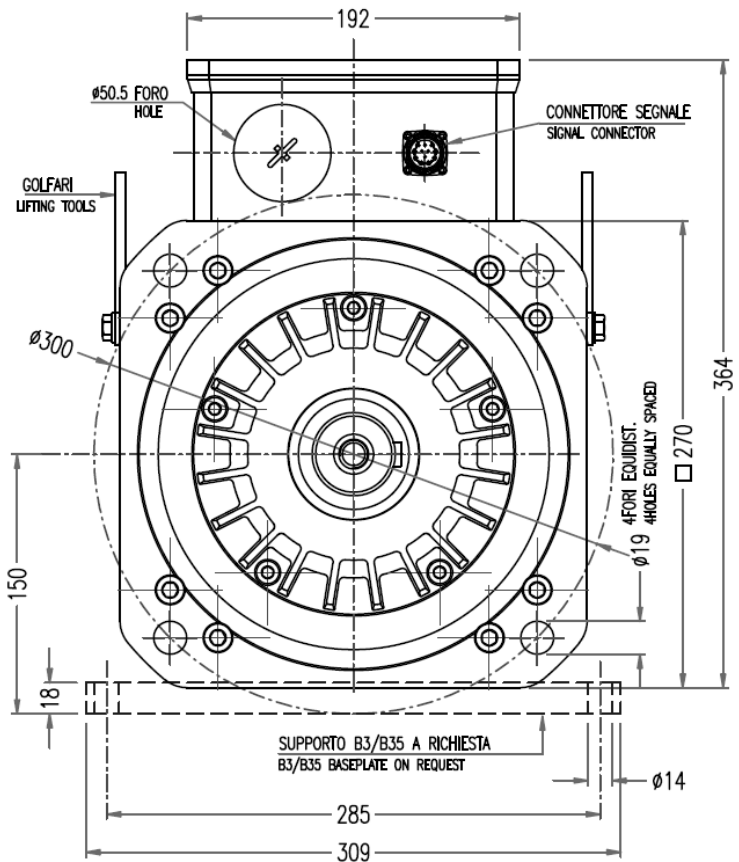
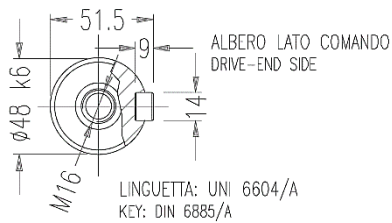

	Without brake		
	B	La	Lt
BR092	200	172	340
BR094	307	279	447
BR096	414	386	554
BR098	521	493	661

	With brake		
	B	La	Lt
BR092	335	307	475
BR094	442	414	582
BR096	549	521	689
BR098	656	628	796

5.5.8 Overall dimensions – BR098304

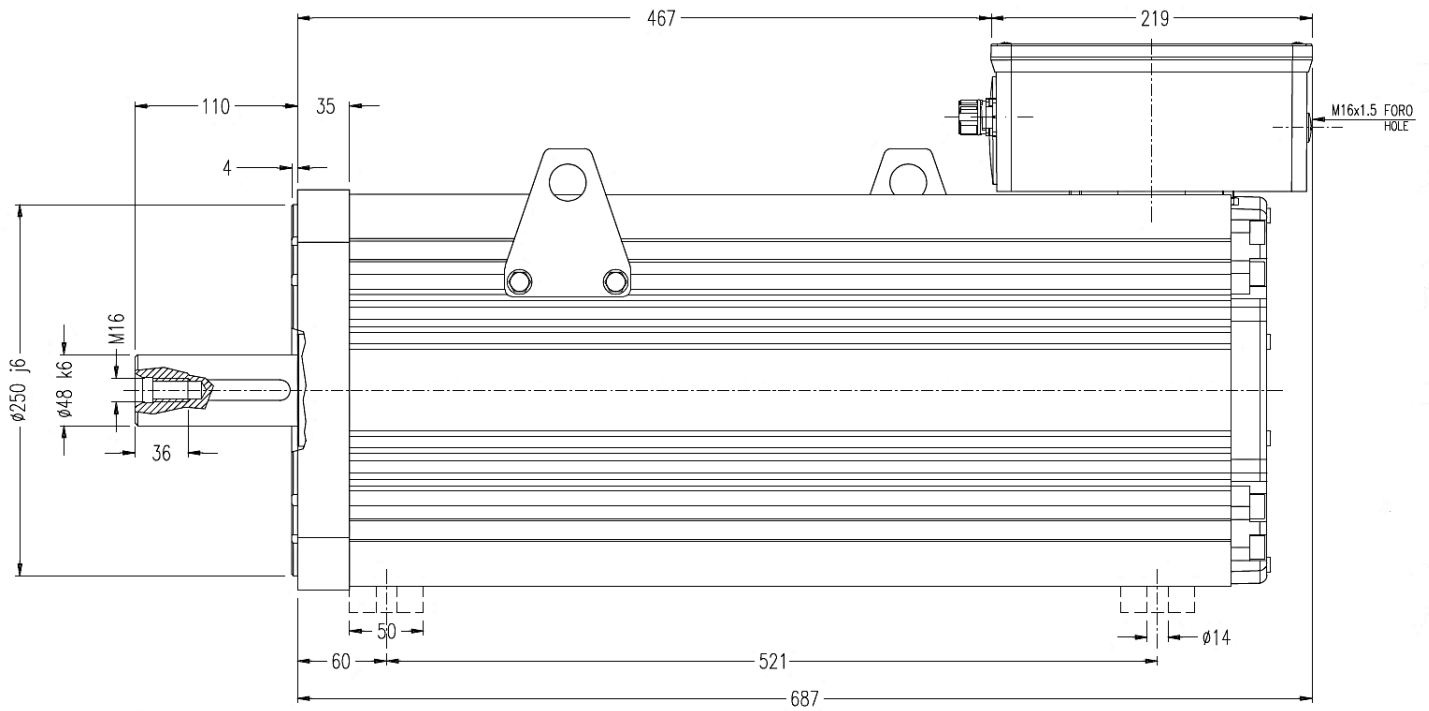

VENTILATION: FREE CONVECTION IC410

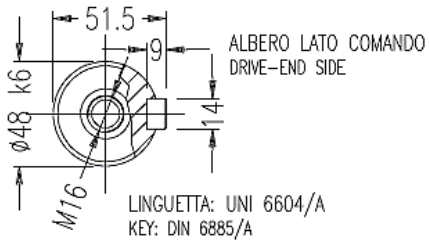

	BR098304		
	B	La	Lt
Without brake	521	467	687
With brake	656	602	822

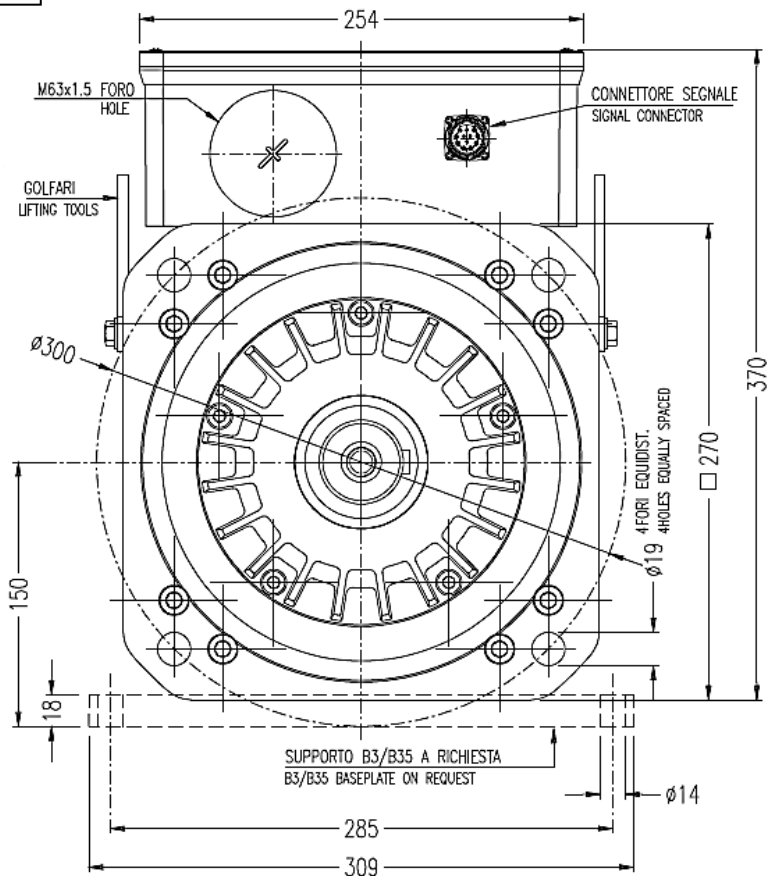

5.5.9 Overall dimensions – BRV9 (except BRV98284)

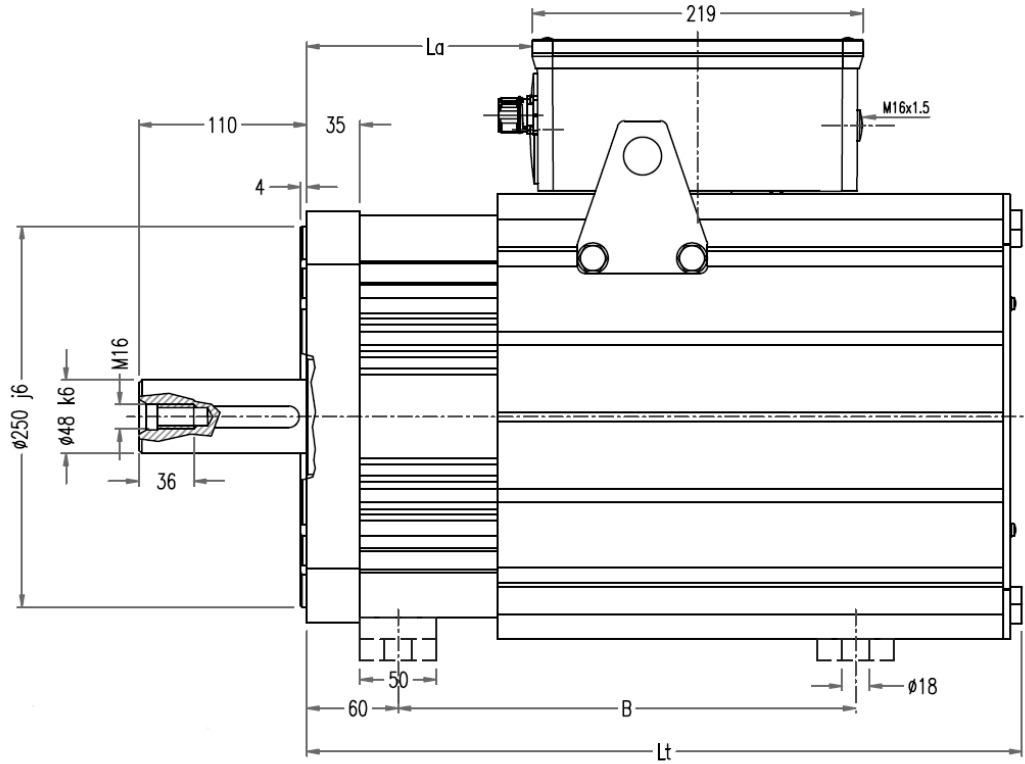

VENTILATION: FORCED CONVECTION IC416

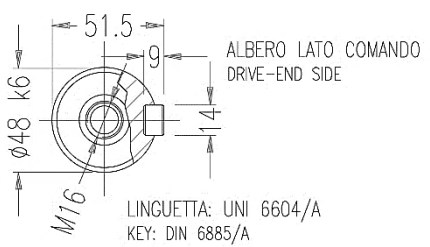

	Without brake		
	B	La	Lt
BRV92	300	146.5	470
BRV94	407	253.5	577
BRV96	514	360.5	684
BRV98	621	467.5	791

	With brake		
	B	La	Lt
BRV92	435	281.5	605
BRV94	542	388.5	712
BRV96	649	495.5	819
BRV98	756	602.5	926

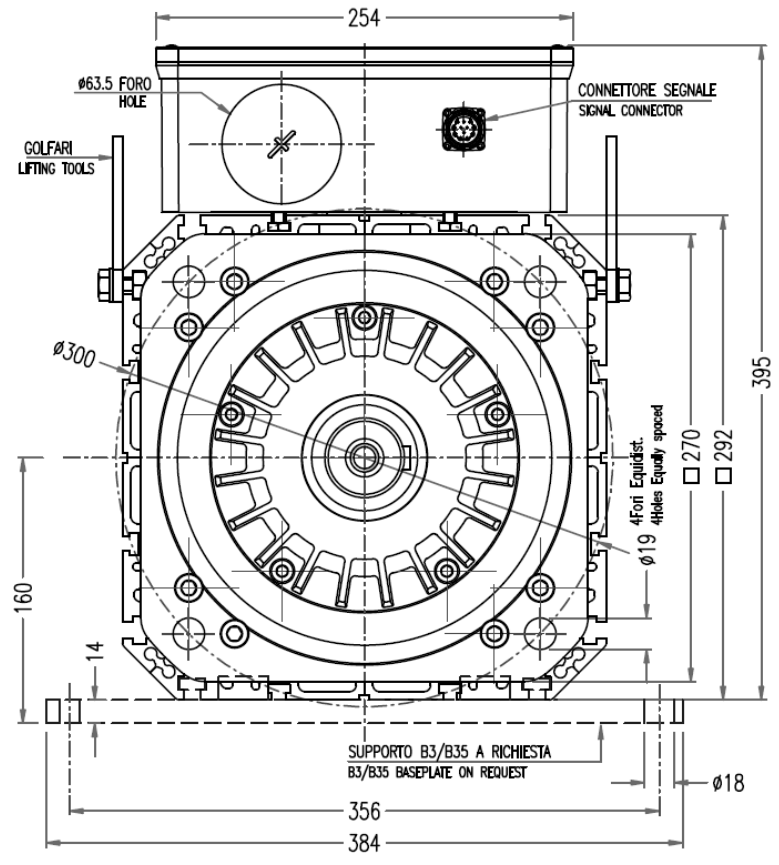

5.5.10 Overall dimensions – BRV98284

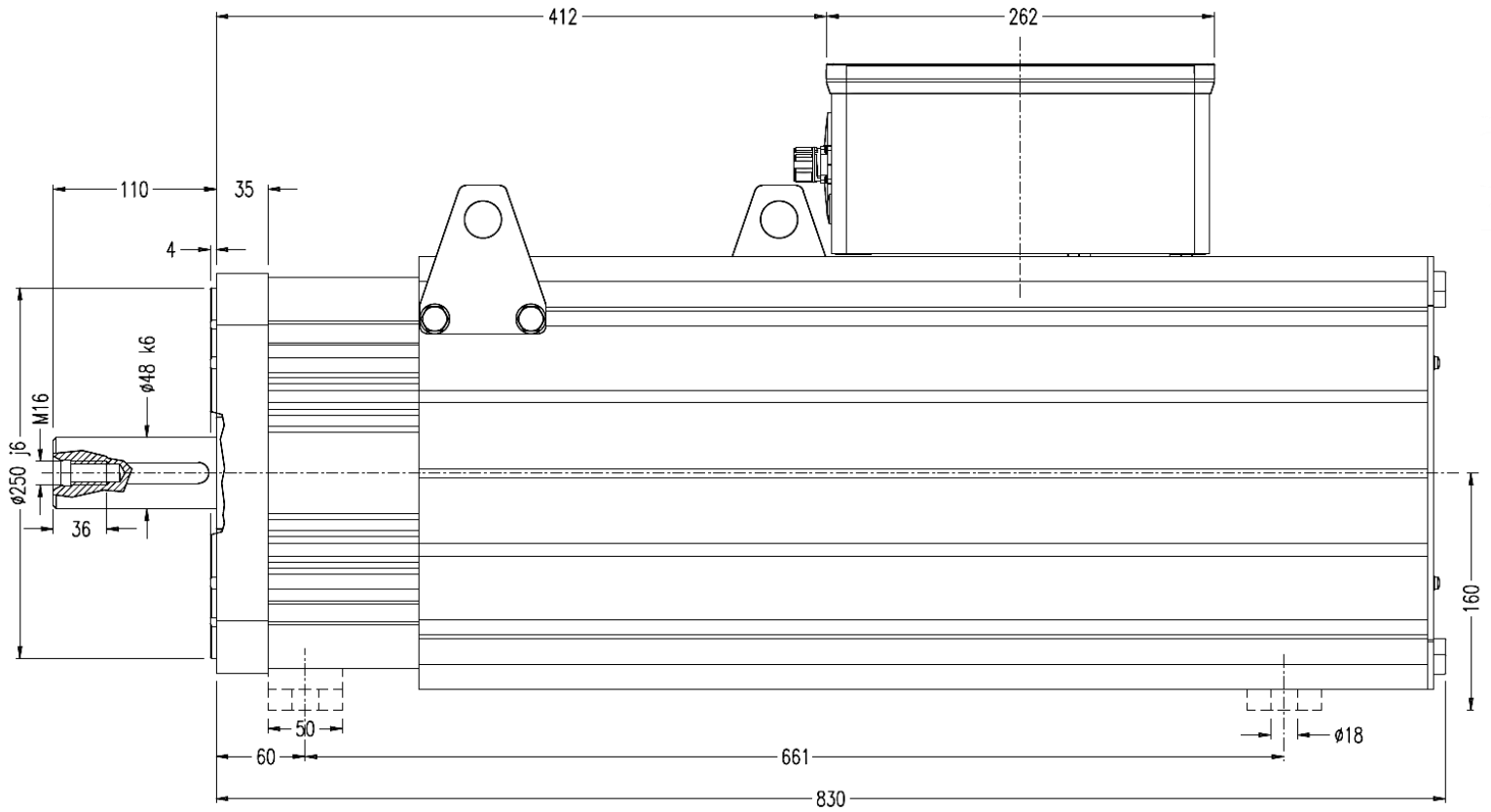

VENTILATION: FORCED CONVECTION IC416

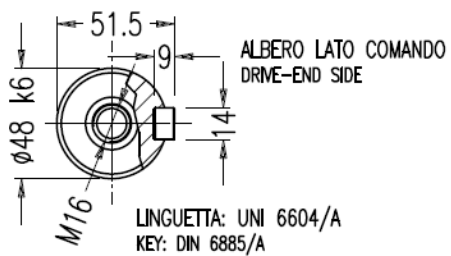

BRV98284			
	B	La	Lt
Without brake	661	412	830
With brake	796	547	965

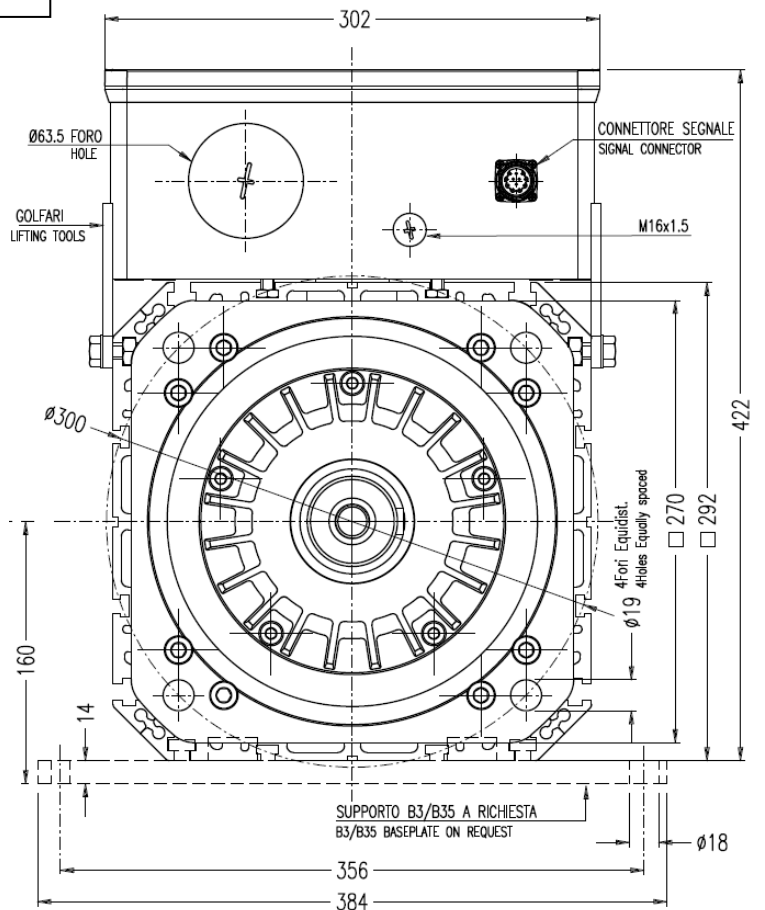

5.6 Characteristic curves torque-speed

This chapter contains torque-speed characteristic curves of the motors described in the manual.

For motors supplied by 230 Vac inverters, curves represented are:

- Peak torque with peak current, motor temperature 20°C, and voltage 215 Vrms
- Peak torque with peak current, motor overtemperature 105 °C, and voltage 215 Vrms
- Peak torque with peak current, motor temperature 20°C, and voltage 250 Vrms
- Peak torque with peak current, motor overtemperature 105 °C, and voltage 250 Vrms
- Nominal torque in Continuous duty S1, motor with 105°C overtemperature

For motors supplied by 400 Vac inverters, curves represented are:

- Peak torque with peak current, motor temperature 20°C, and voltage 360 Vrms
- Peak torque with peak current, motor overtemperature 105 °C, and voltage 360 Vrms
- Peak torque with peak current, motor temperature 20°C, and voltage 420 Vrms
- Peak torque with peak current, motor overtemperature 105 °C, and voltage 420 Vrms
- Nominal torque in continuous duty S1, motor with 105°C overtemperature
- Torque in intermittent periodic duty S3, with duty cycle 40%, 1 minute cycle time, overtemperature 105°C.
This curve is present only for certain motor sizes.

5.6.1 Curves motor series BR03

5.6.1.1 Curves BR032 – 230V

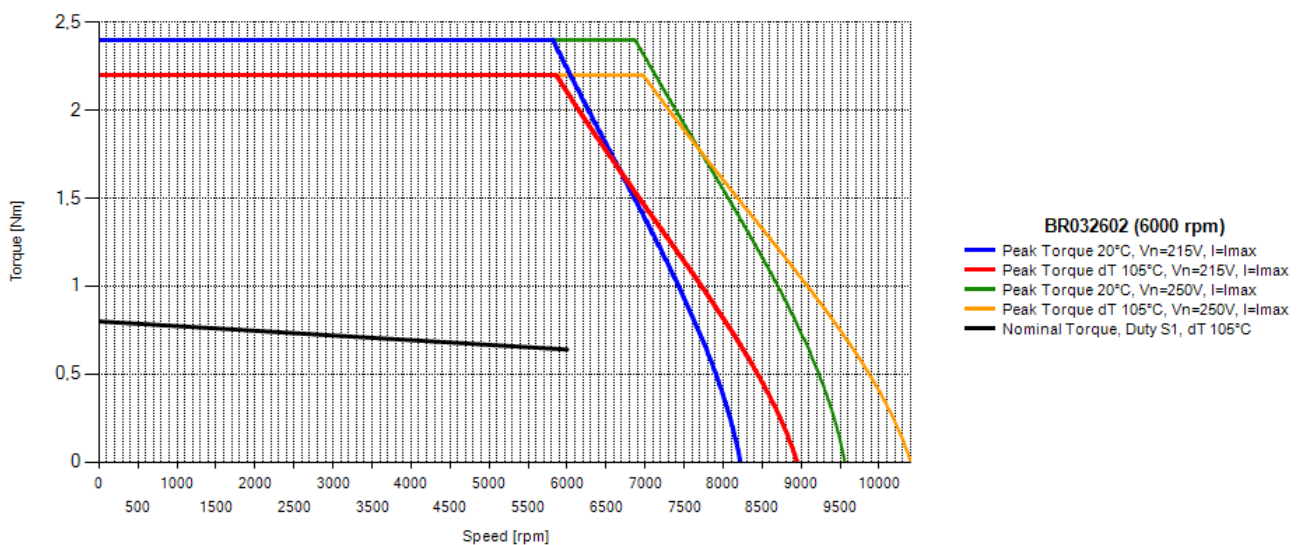
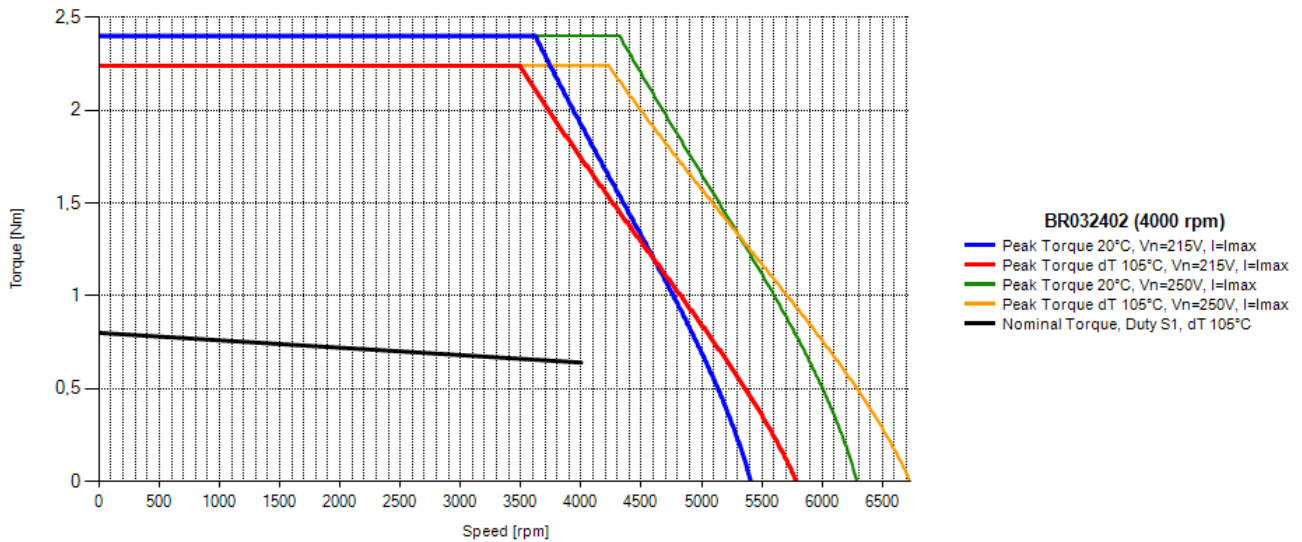
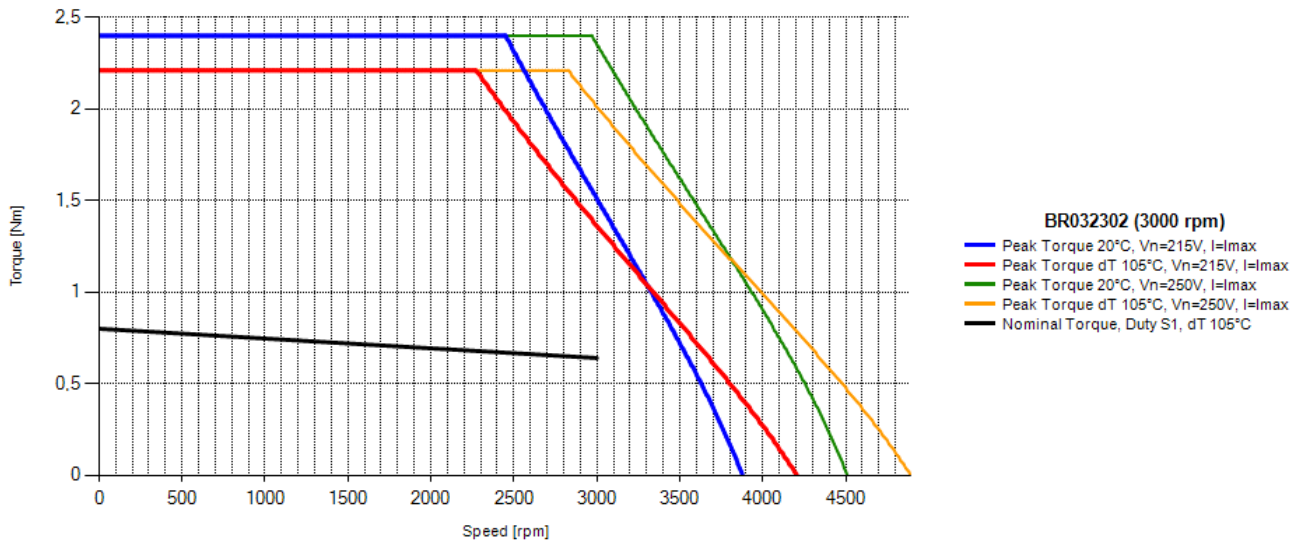

5.6.1.2 Curves BR032 – 400 V

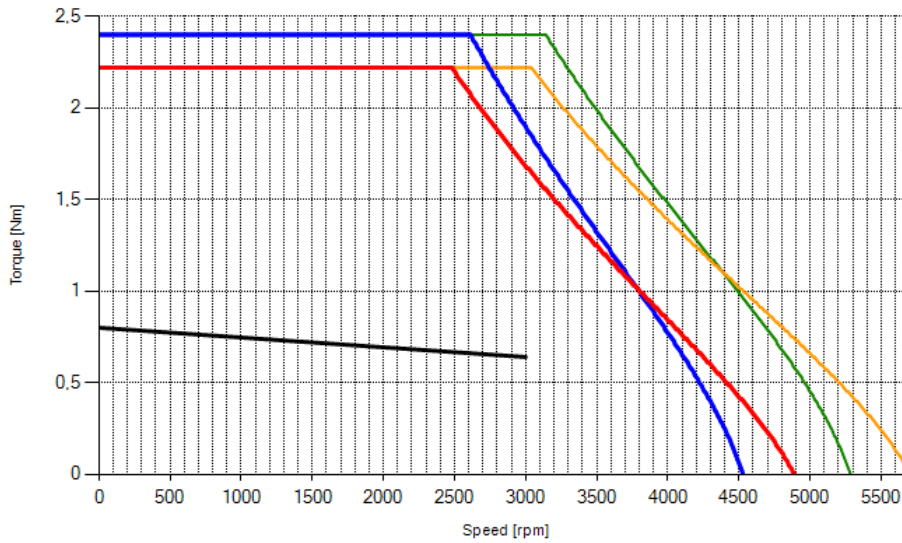

BR032304 (3000 rpm)

- Peak Torque 20°C, Vn=360V, I=Imax
- Peak Torque dT 105°C, Vn=360V, I=Imax
- Peak Torque 20°C, Vn=420V, I=Imax
- Peak Torque dT 105°C, Vn=420V, I=Imax
- Nominal Torque, Duty S1, dT 105°C

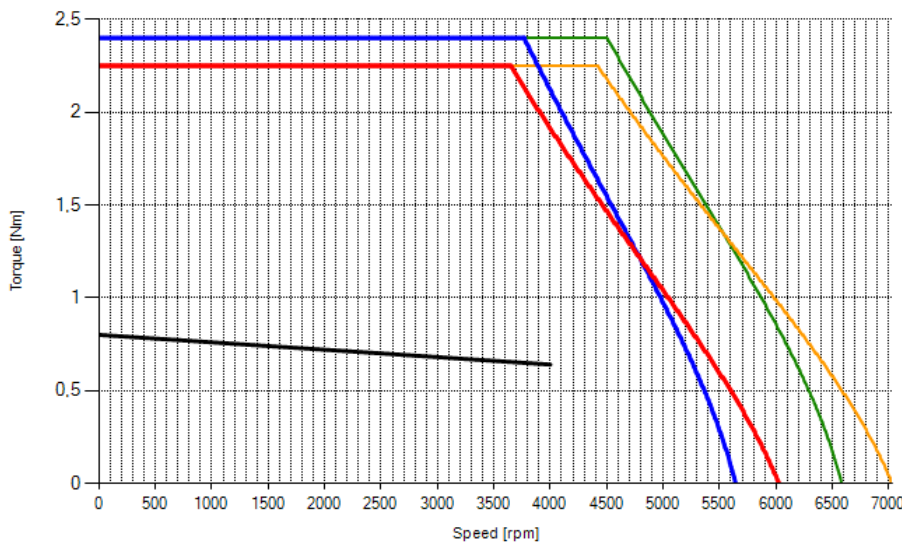

BR032404 (4000 rpm)

- Peak Torque 20°C, Vn=360V, I=Imax
- Peak Torque dT 105°C, Vn=360V, I=Imax
- Peak Torque 20°C, Vn=420V, I=Imax
- Peak Torque dT 105°C, Vn=420V, I=Imax
- Nominal Torque, Duty S1, dT 105°C

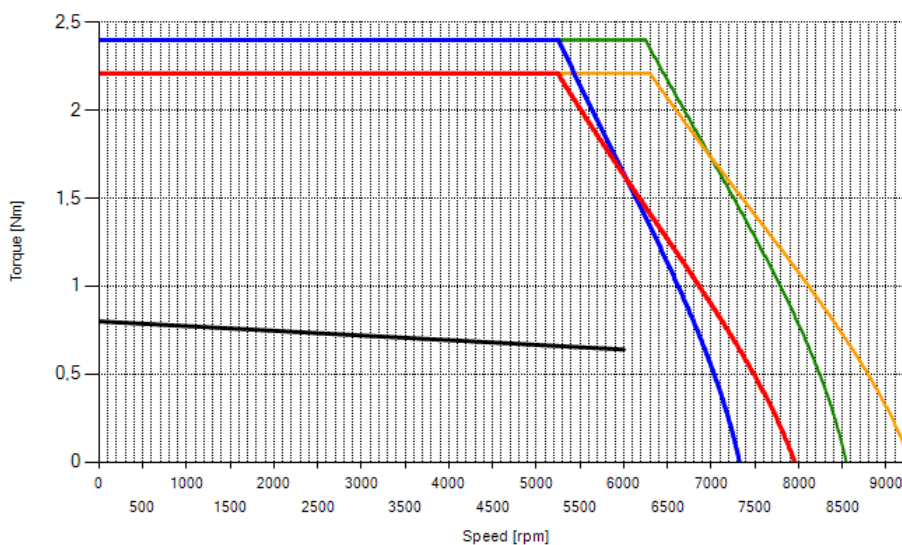

BR032604 (6000 rpm)

- Peak Torque 20°C, Vn=360V, I=Imax
- Peak Torque dT 105°C, Vn=360V, I=Imax
- Peak Torque 20°C, Vn=420V, I=Imax
- Peak Torque dT 105°C, Vn=420V, I=Imax
- Nominal Torque, Duty S1, dT 105°C

5.6.1.3 Curves BR034 – 230 V

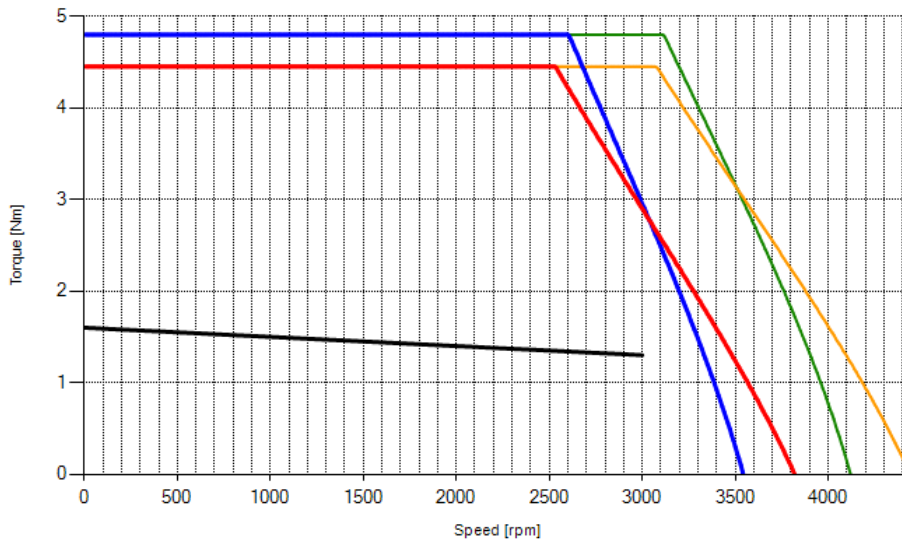

BR034302 (3000 rpm)

- Peak Torque 20°C, Vn=215V, I=Imax
- Peak Torque dT 105°C, Vn=215V, I=Imax
- Peak Torque 20°C, Vn=250V, I=Imax
- Peak Torque dT 105°C, Vn=250V, I=Imax
- Nominal Torque, Duty S1, dT 105°C

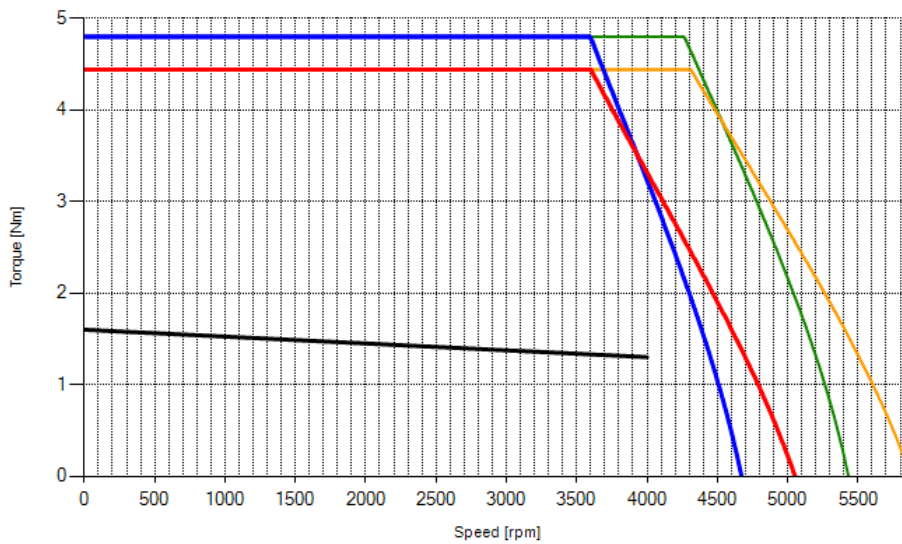

BR034402 (4000 rpm)

- Peak Torque 20°C, Vn=215V, I=Imax
- Peak Torque dT 105°C, Vn=215V, I=Imax
- Peak Torque 20°C, Vn=250V, I=Imax
- Peak Torque dT 105°C, Vn=250V, I=Imax
- Nominal Torque, Duty S1, dT 105°C

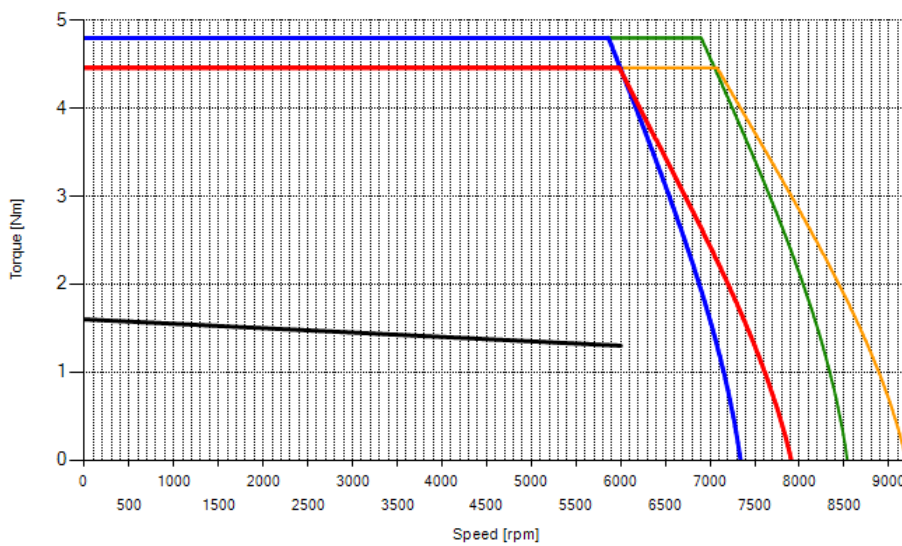

BR034602 (6000 rpm)

- Peak Torque 20°C, Vn=215V, I=Imax
- Peak Torque dT 105°C, Vn=215V, I=Imax
- Peak Torque 20°C, Vn=250V, I=Imax
- Peak Torque dT 105°C, Vn=250V, I=Imax
- Nominal Torque, Duty S1, dT 105°C

5.6.1.4 Curves BR034 – 400 V

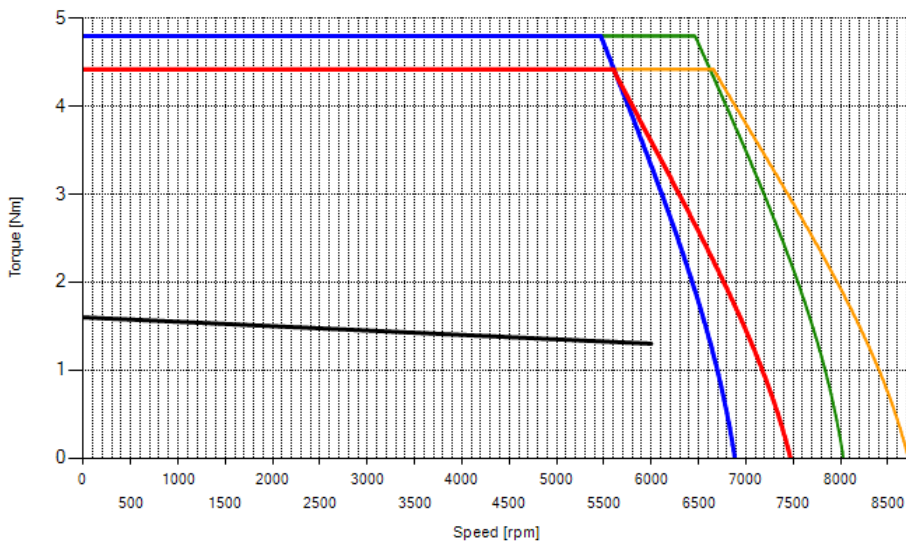
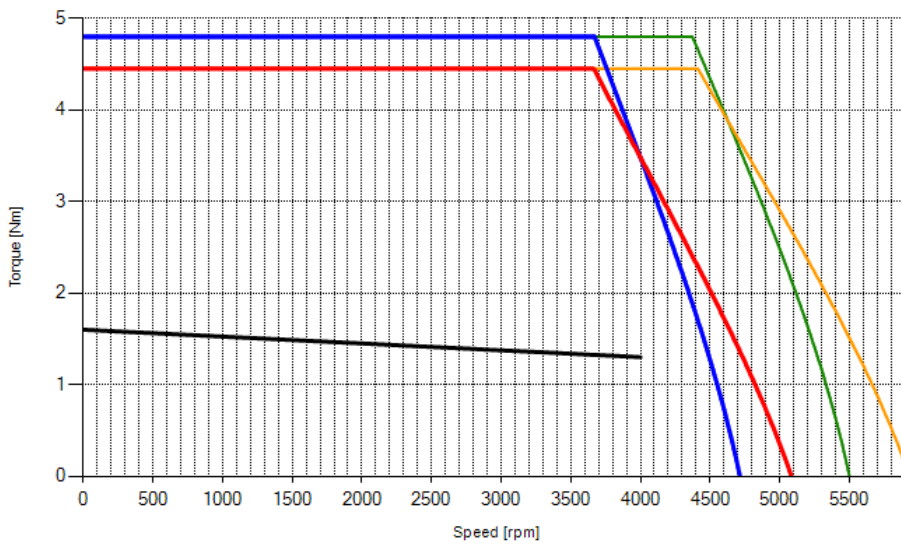
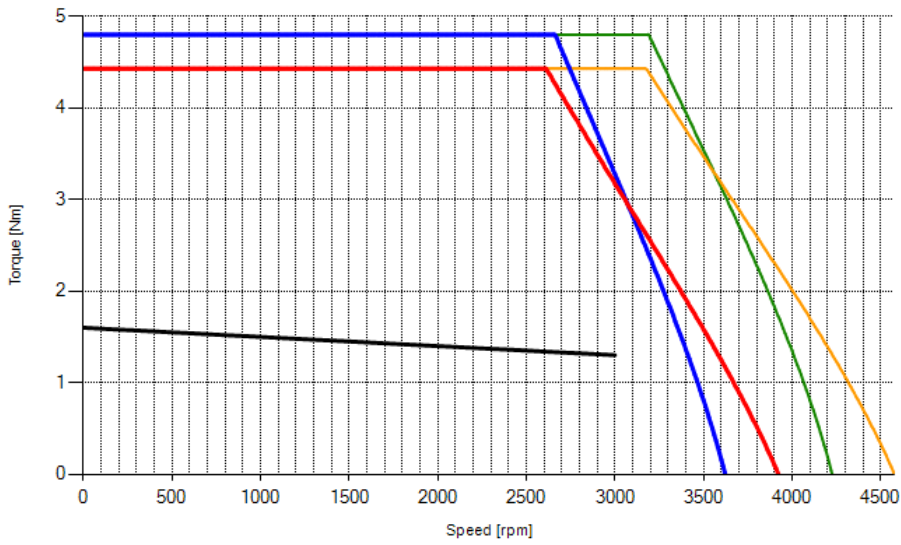

5.6.1.5 Curves BR036 – 230 V

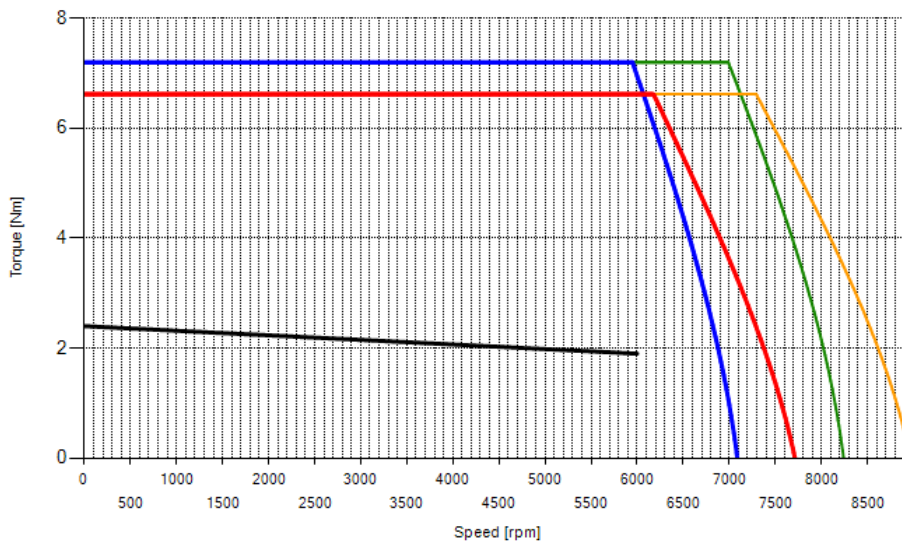
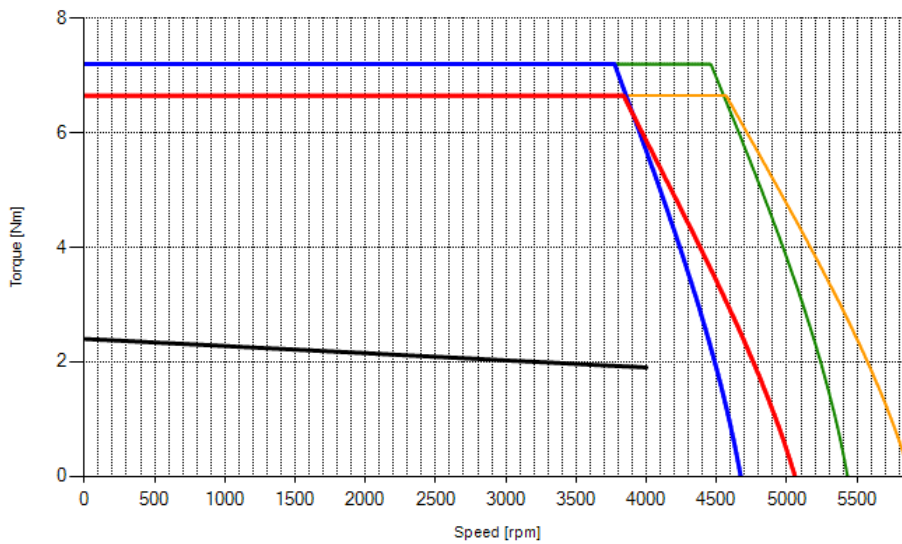
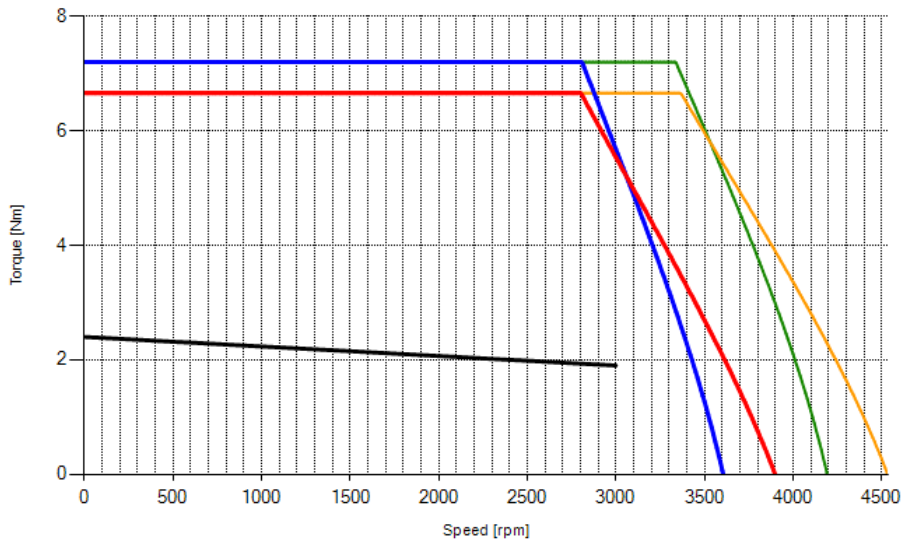

5.6.1.6 Curves BR036 – 400 V

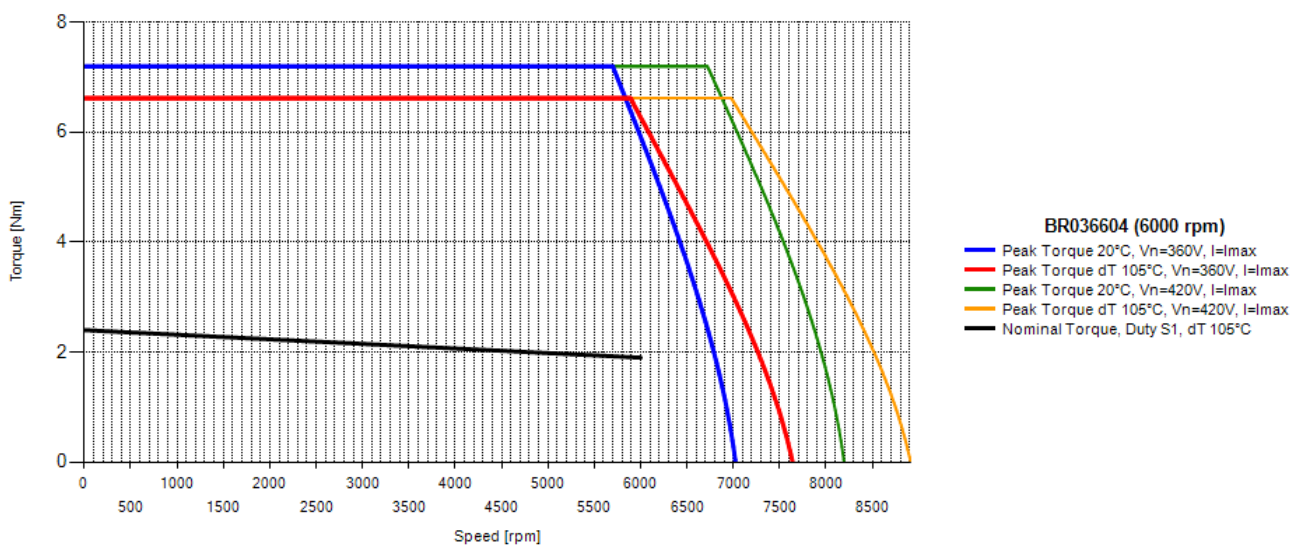
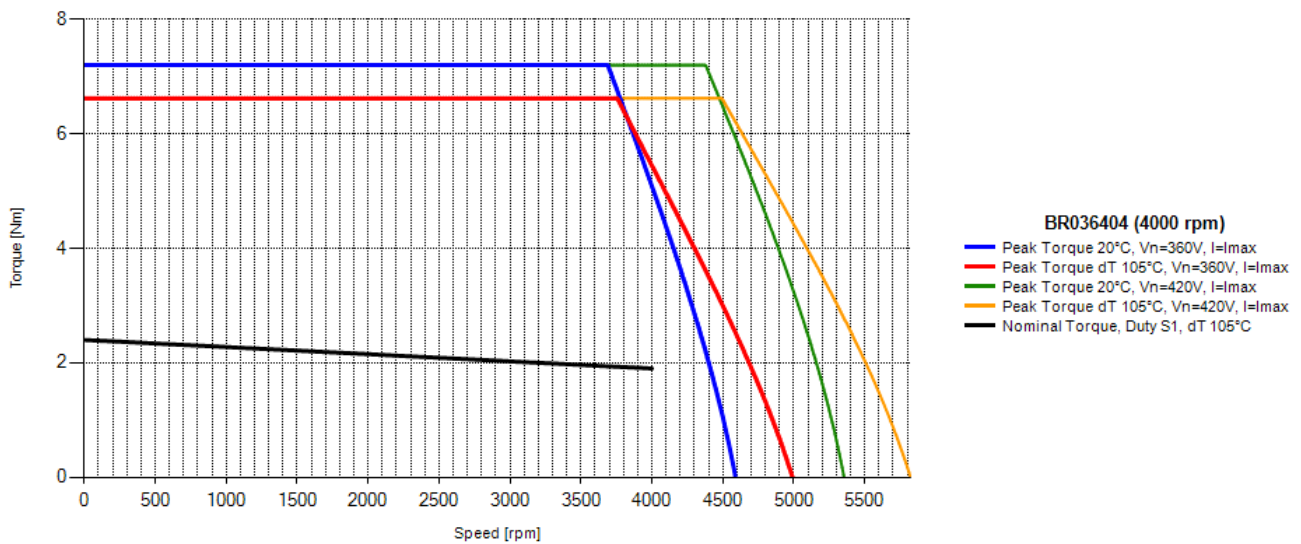
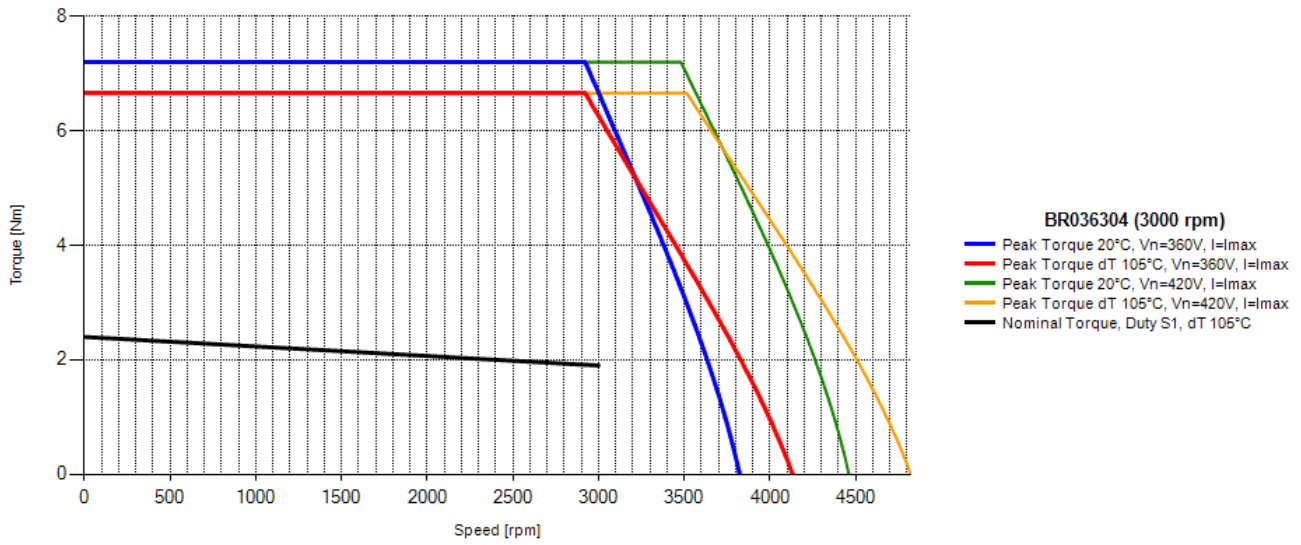

5.6.1.7 Curves BR038 – 230 V

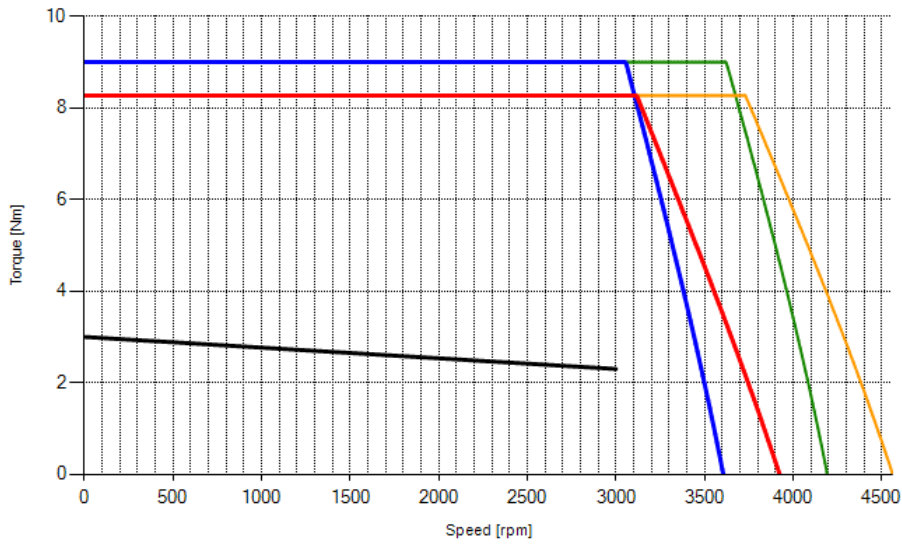

BR038302 (3000 rpm)

- Peak Torque 20°C, Vn=215V, I=Imax
- Peak Torque dT 105°C, Vn=215V, I=Imax
- Peak Torque 20°C, Vn=250V, I=Imax
- Peak Torque dT 105°C, Vn=250V, I=Imax
- Nominal Torque, Duty S1, dT 105°C

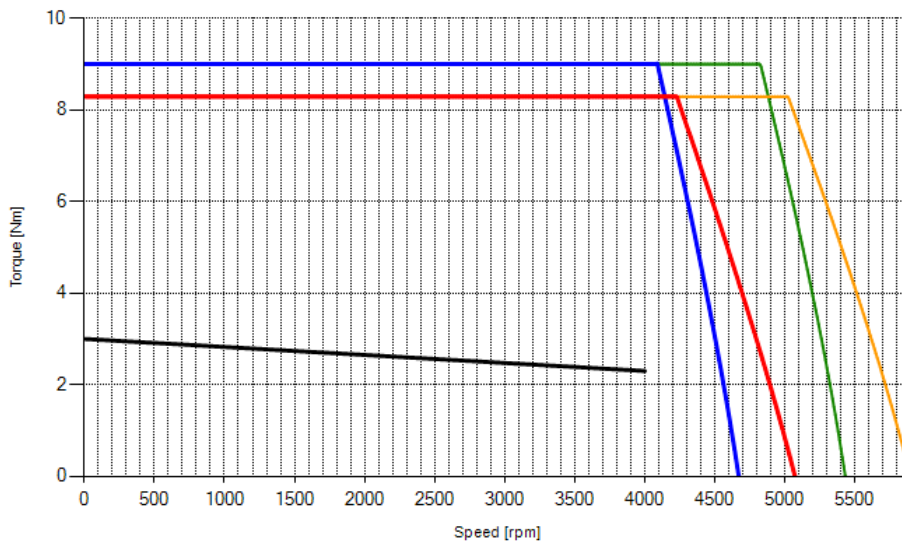

BR038402 (4000 rpm)

- Peak Torque 20°C, Vn=215V, I=Imax
- Peak Torque dT 105°C, Vn=215V, I=Imax
- Peak Torque 20°C, Vn=250V, I=Imax
- Peak Torque dT 105°C, Vn=250V, I=Imax
- Nominal Torque, Duty S1, dT 105°C

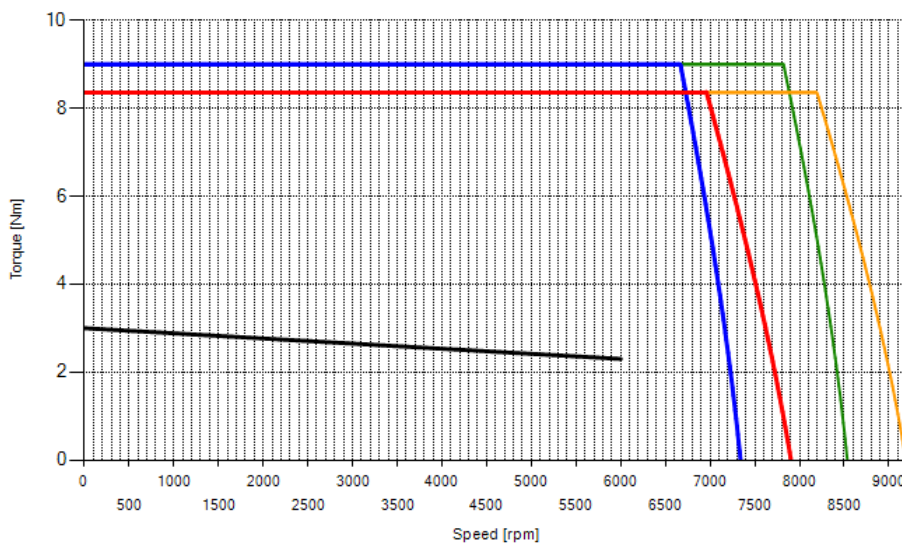

BR038602 (6000 rpm)

- Peak Torque 20°C, Vn=215V, I=Imax
- Peak Torque dT 105°C, Vn=215V, I=Imax
- Peak Torque 20°C, Vn=250V, I=Imax
- Peak Torque dT 105°C, Vn=250V, I=Imax
- Nominal Torque, Duty S1, dT 105°C

5.6.1.8 Curves BR038 – 400 V

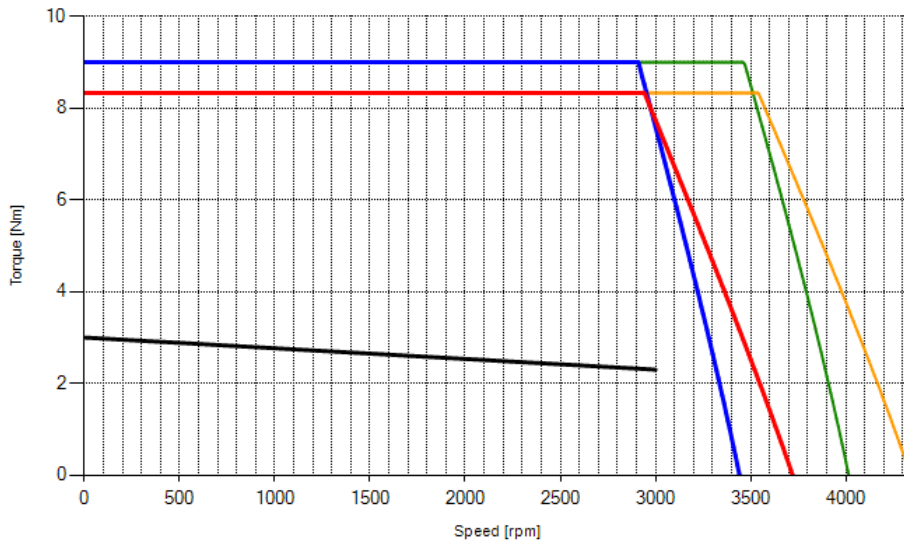

BR038304 (3000 rpm)
 — Peak Torque 20°C, Vn=360V, I=Imax
 — Peak Torque dT 105°C, Vn=360V, I=Imax
 — Peak Torque 20°C, Vn=420V, I=Imax
 — Peak Torque dT 105°C, Vn=420V, I=Imax
 — Nominal Torque, Duty S1, dT 105°C

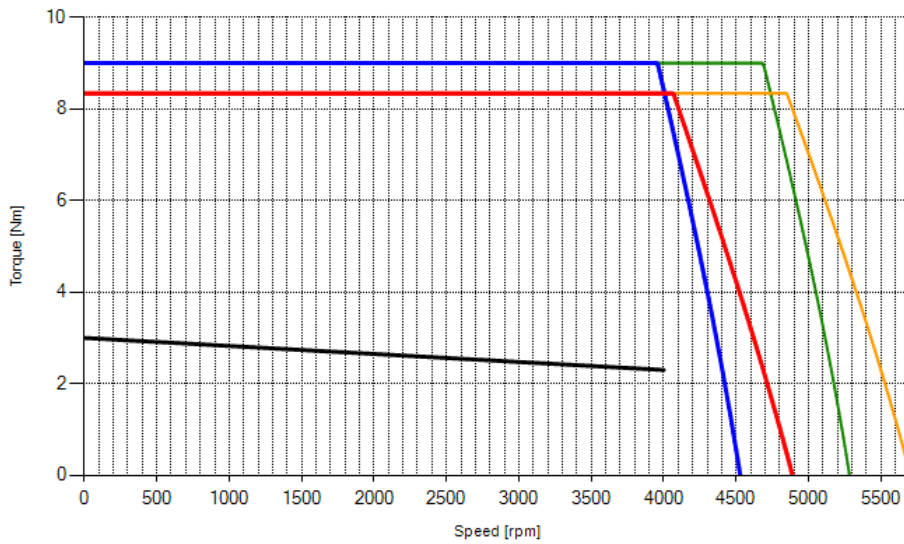

BR038404 (4000 rpm)
 — Peak Torque 20°C, Vn=360V, I=Imax
 — Peak Torque dT 105°C, Vn=360V, I=Imax
 — Peak Torque 20°C, Vn=420V, I=Imax
 — Peak Torque dT 105°C, Vn=420V, I=Imax
 — Nominal Torque, Duty S1, dT 105°C

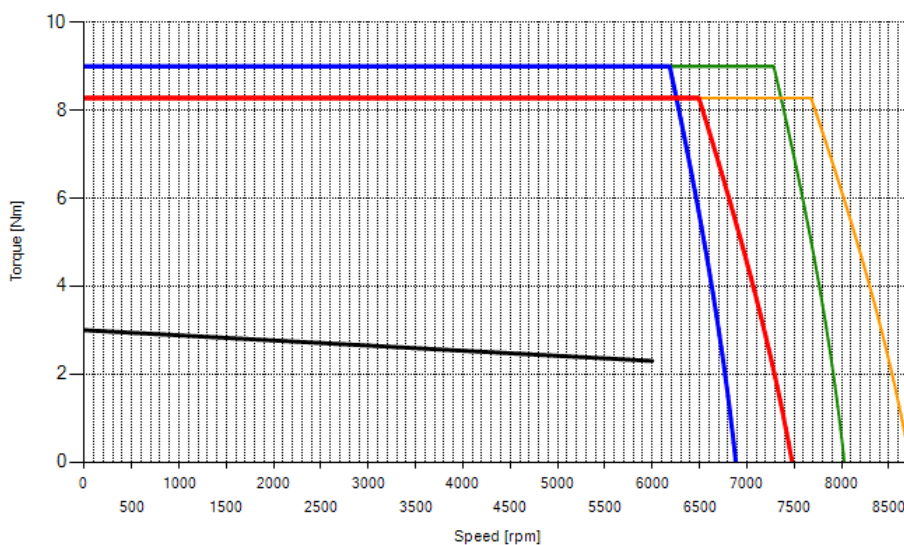

BR038604 (6000 rpm)
 — Peak Torque 20°C, Vn=360V, I=Imax
 — Peak Torque dT 105°C, Vn=360V, I=Imax
 — Peak Torque 20°C, Vn=420V, I=Imax
 — Peak Torque dT 105°C, Vn=420V, I=Imax
 — Nominal Torque, Duty S1, dT 105°C

5.6.2 Curves motor series BR05

5.6.2.1 Curves BR051 – 400 V

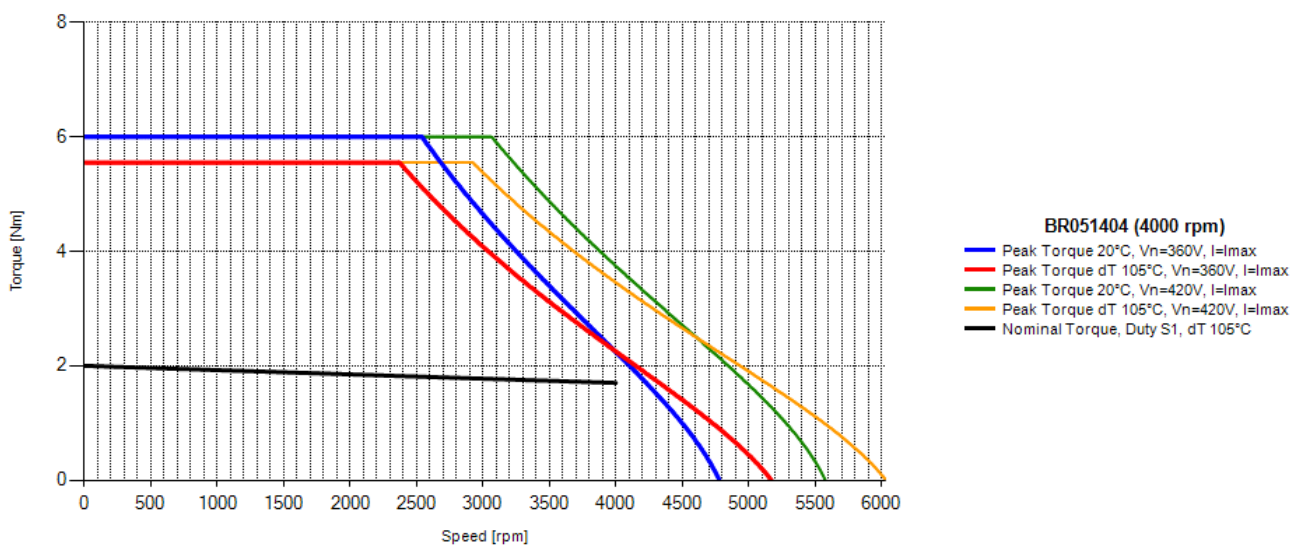
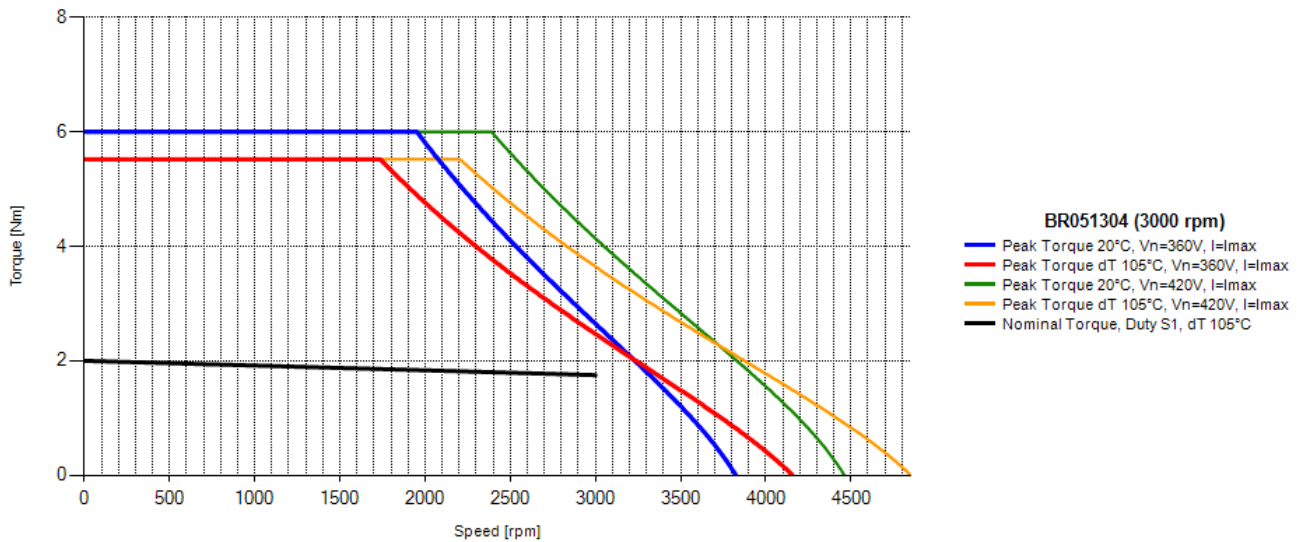
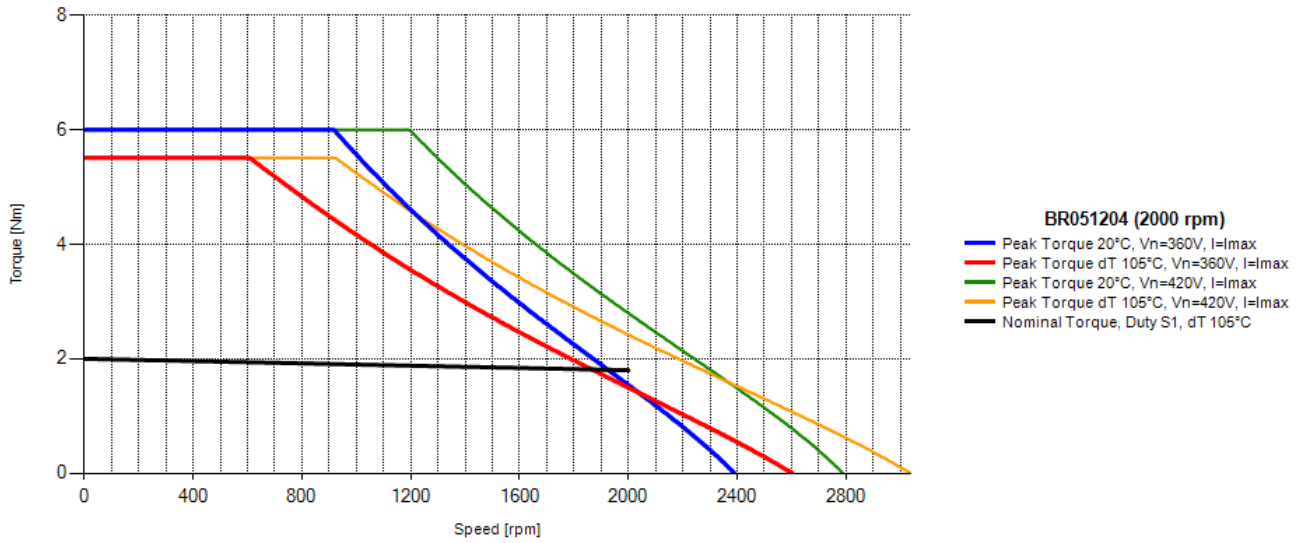

5.6.2.2 Curves BR052 – 400 V

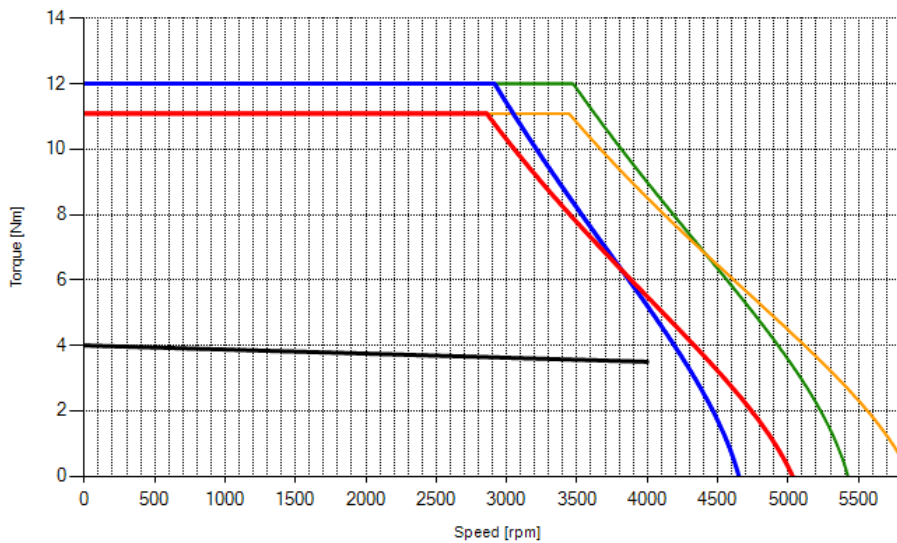
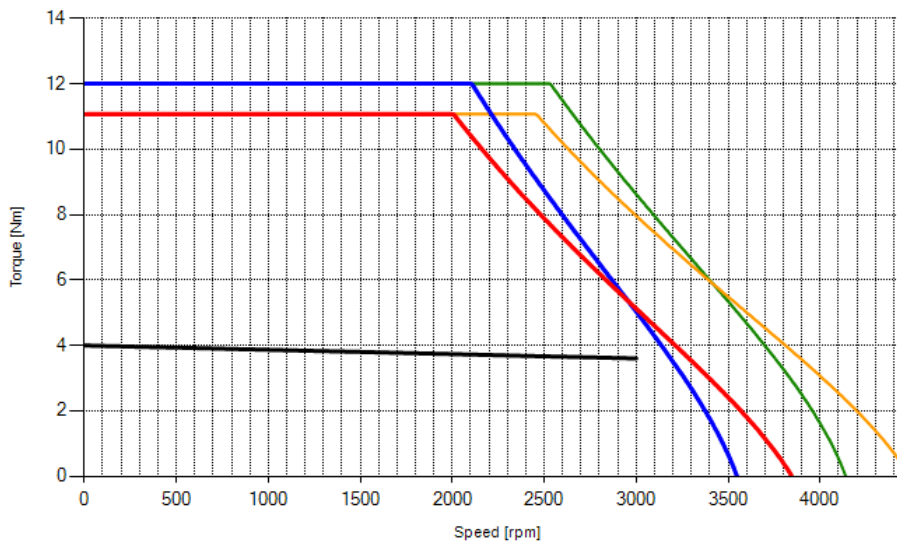
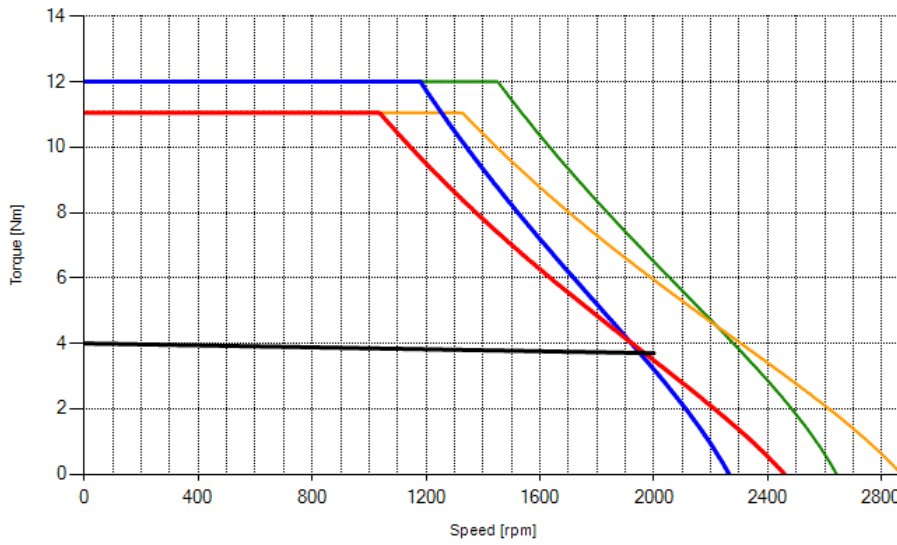

5.6.2.3 Curves BR053 – 400 V

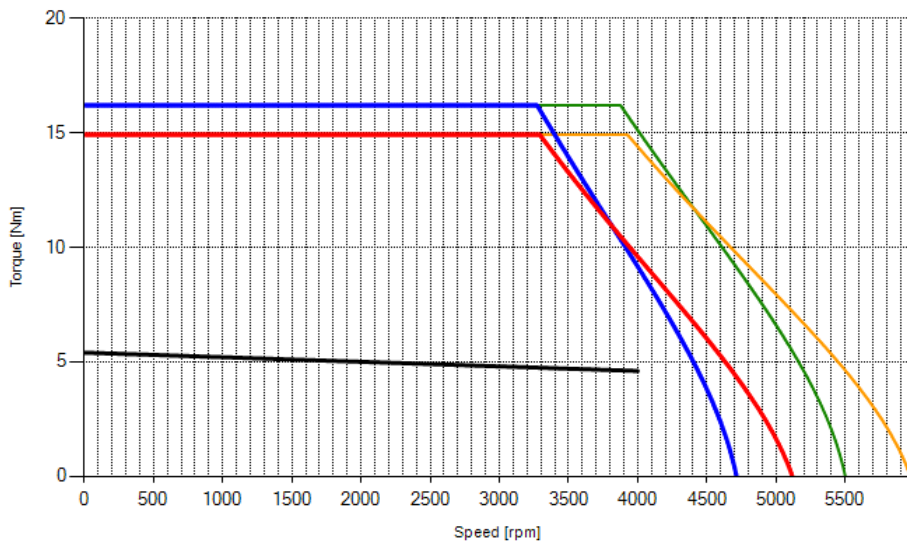
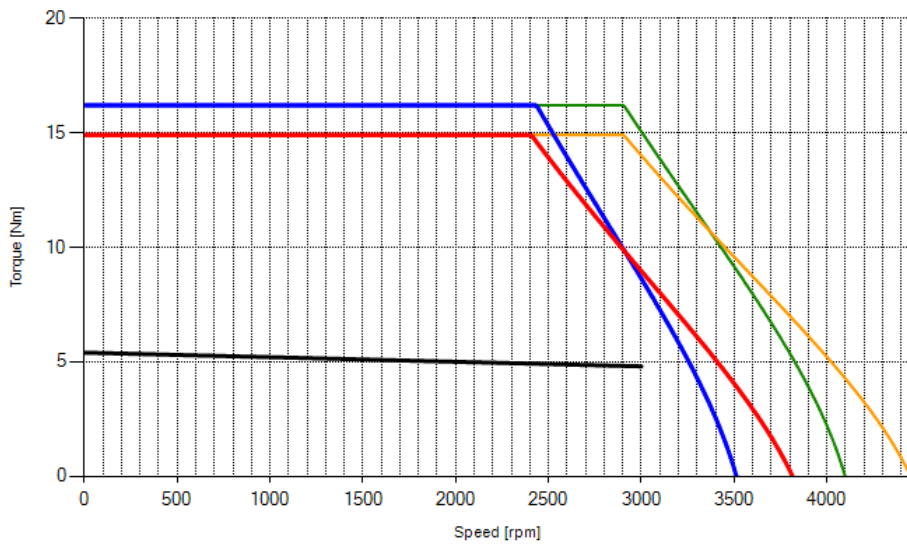
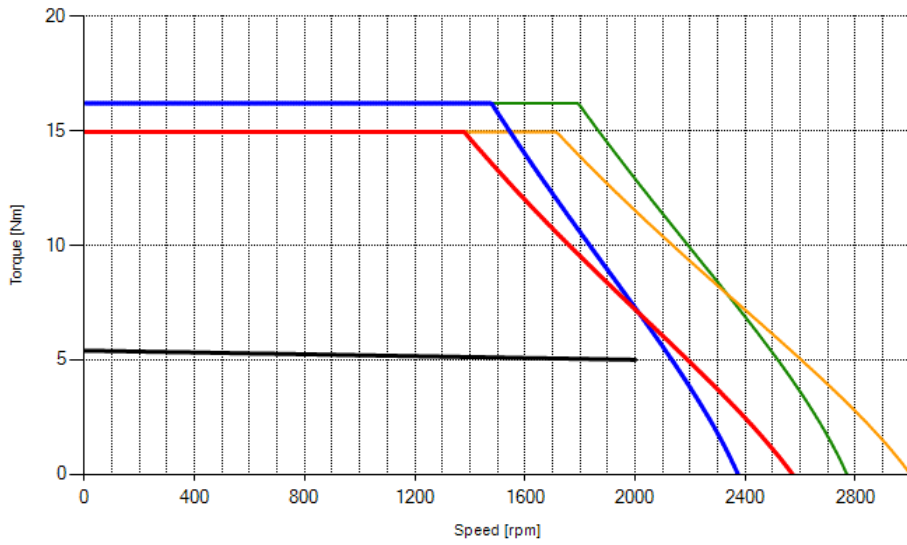

5.6.2.4 Curves BR054 – 400 V

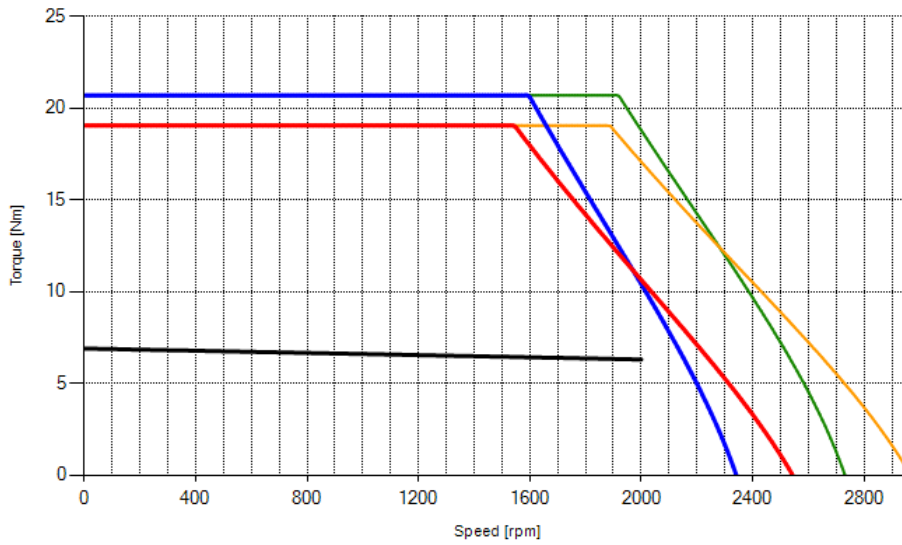

BR054204 (2000 rpm)

- Peak Torque 20°C, Vn=360V, I=Imax
- Peak Torque dT 105°C, Vn=360V, I=Imax
- Peak Torque 20°C, Vn=420V, I=Imax
- Peak Torque dT 105°C, Vn=420V, I=Imax
- Nominal Torque, Duty S1, dT 105°C

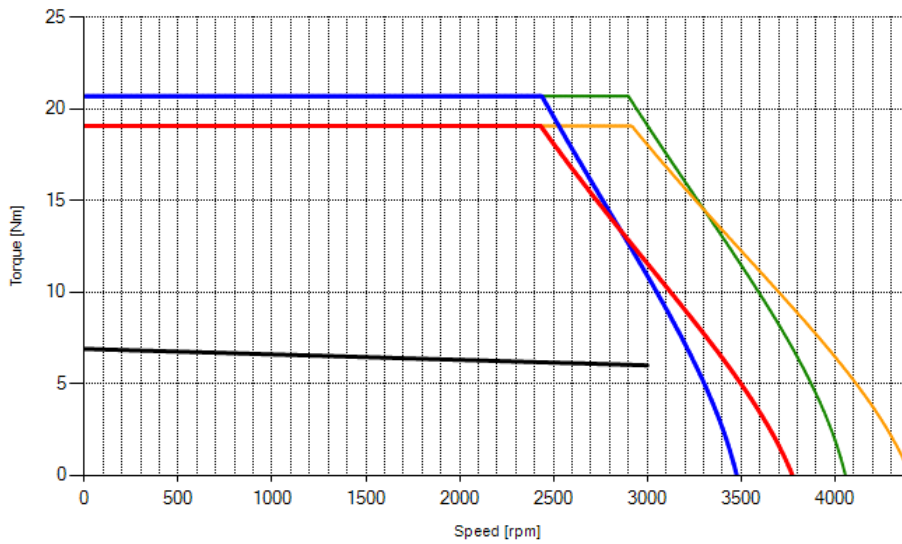

BR054304 (3000 rpm)

- Peak Torque 20°C, Vn=360V, I=Imax
- Peak Torque dT 105°C, Vn=360V, I=Imax
- Peak Torque 20°C, Vn=420V, I=Imax
- Peak Torque dT 105°C, Vn=420V, I=Imax
- Nominal Torque, Duty S1, dT 105°C

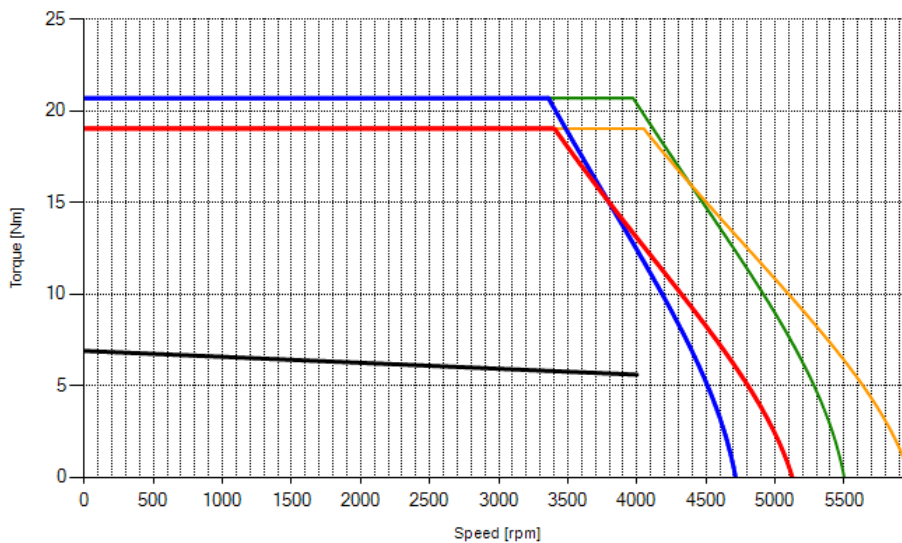

BR054404 (4000 rpm)

- Peak Torque 20°C, Vn=360V, I=Imax
- Peak Torque dT 105°C, Vn=360V, I=Imax
- Peak Torque 20°C, Vn=420V, I=Imax
- Peak Torque dT 105°C, Vn=420V, I=Imax
- Nominal Torque, Duty S1, dT 105°C

5.6.2.5 Curves BR055 – 400 V

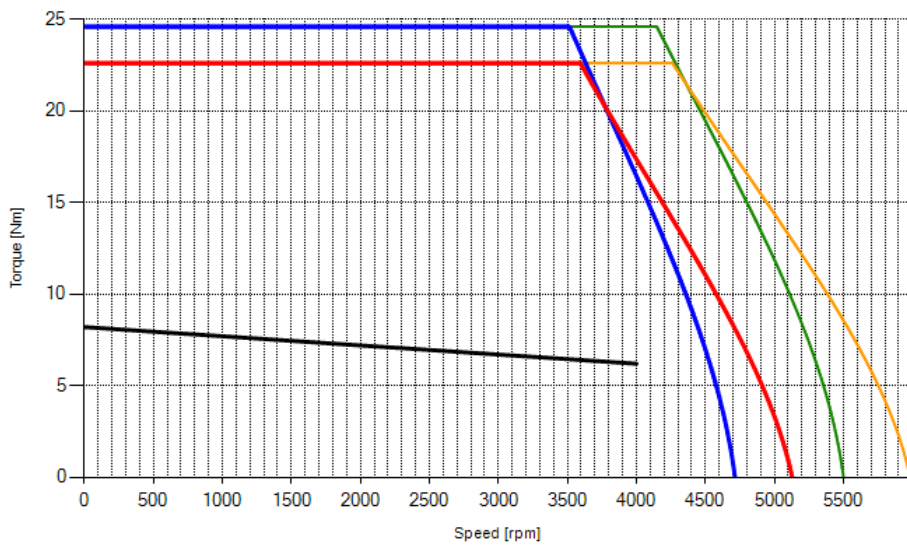
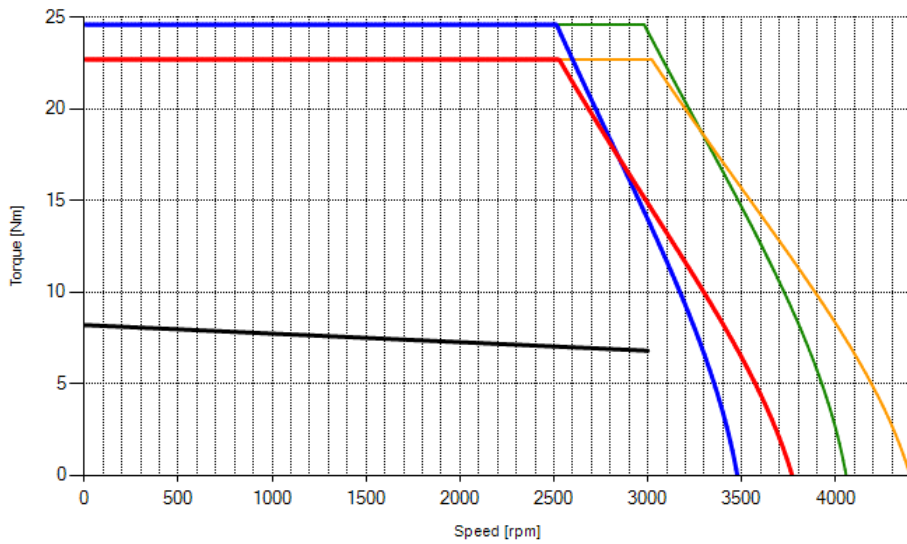
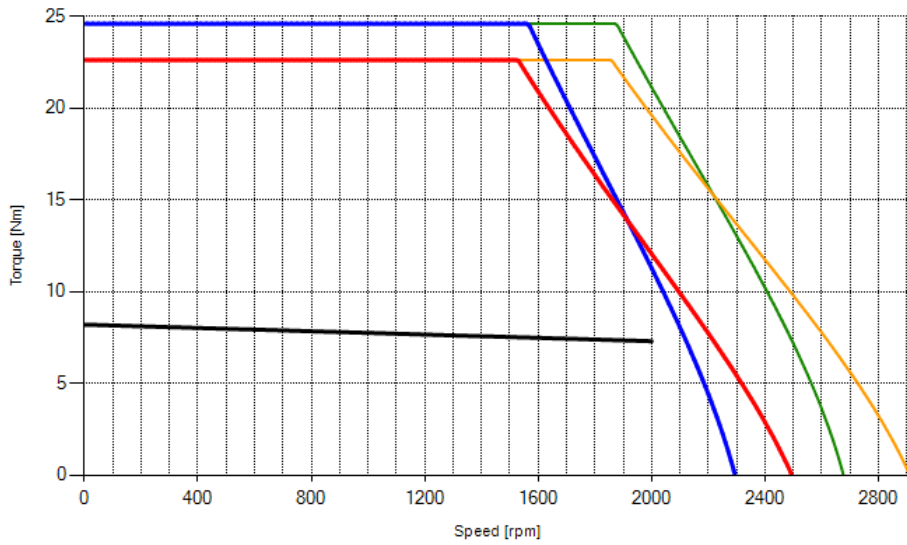

5.6.2.6 Curves BR056 – 400 V

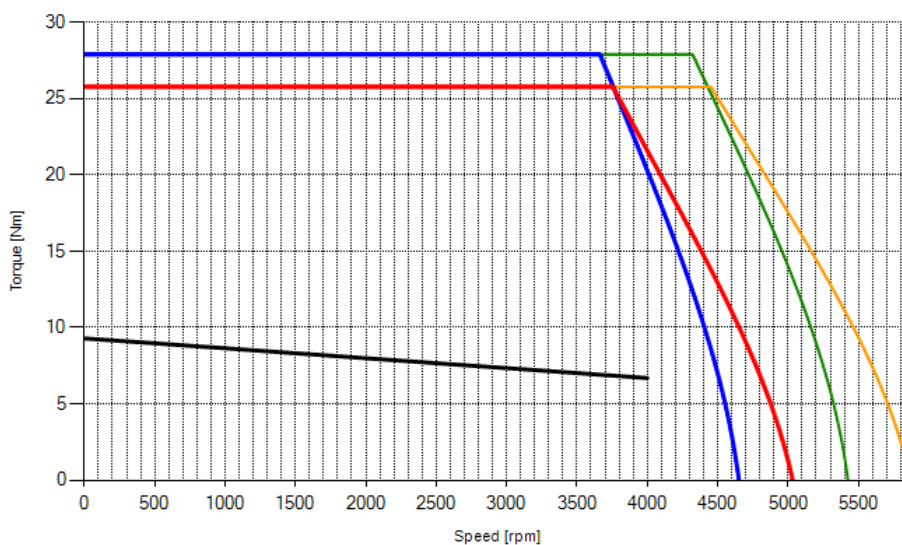
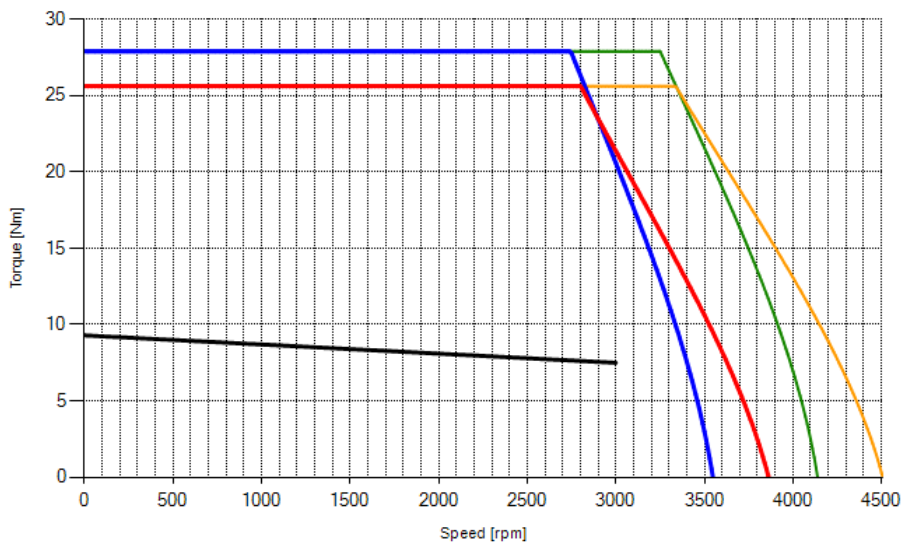
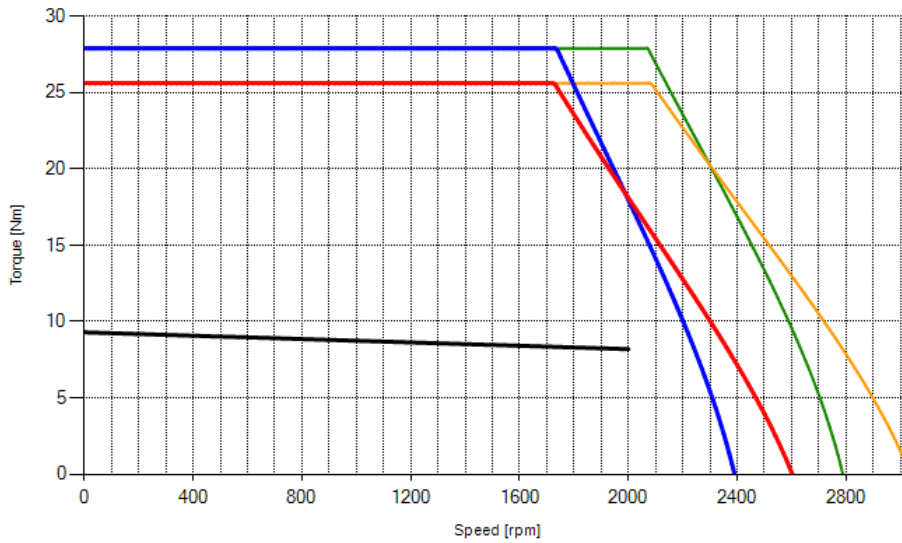

5.6.2.7 Curves BR057 – 400 V

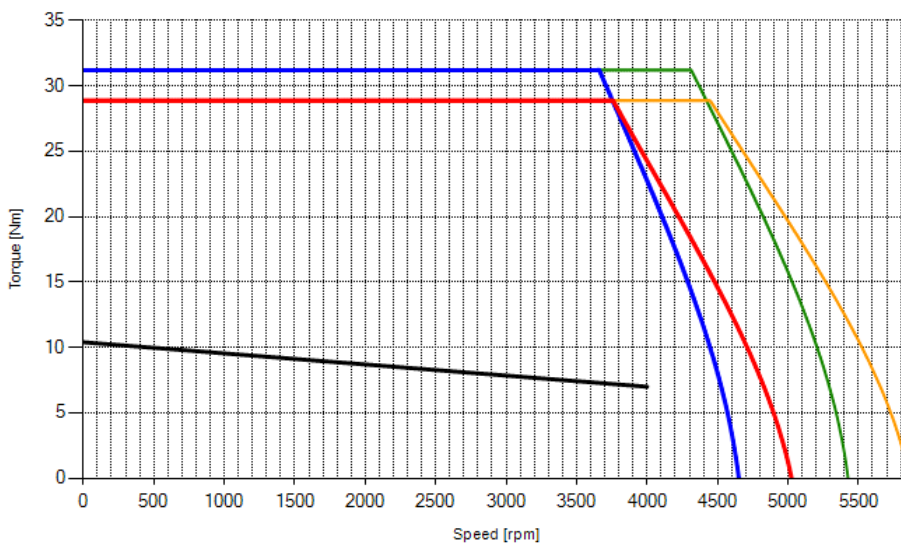
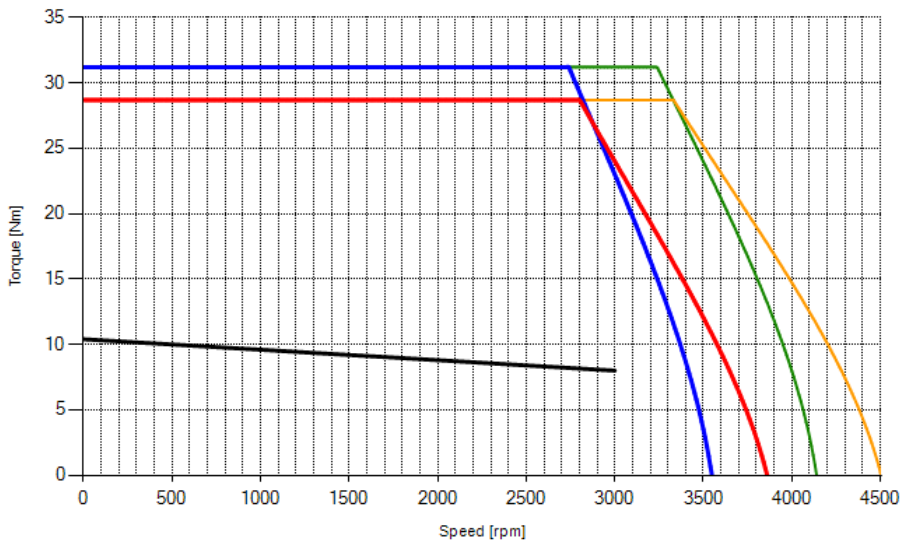
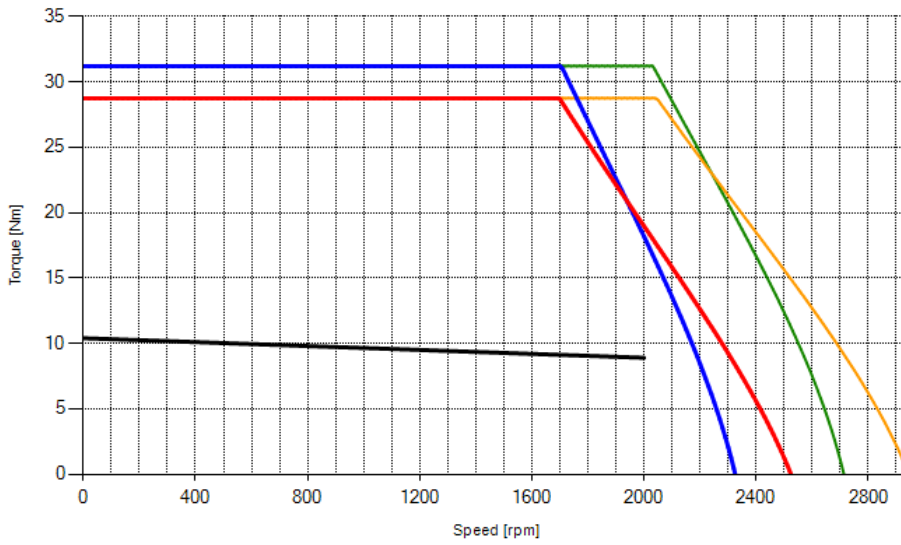

5.6.2.8 Curves BR058 – 400 V

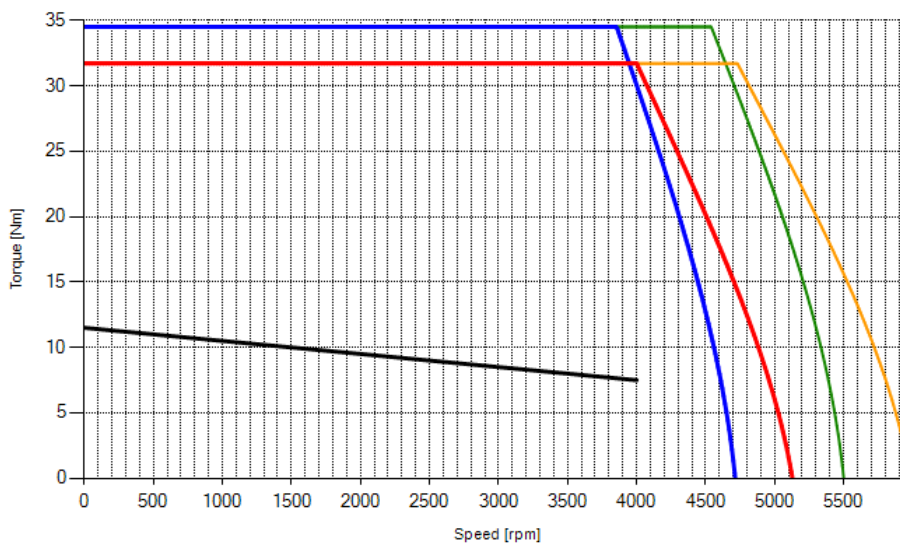
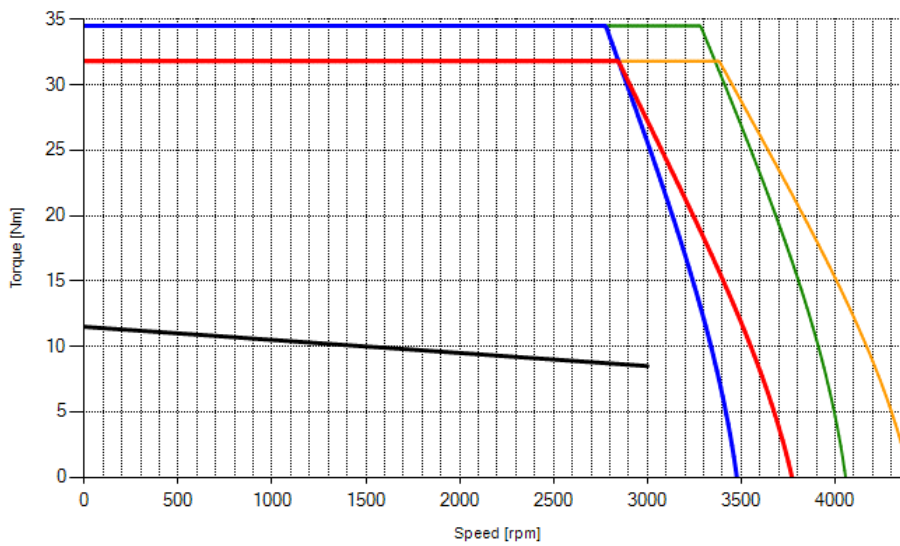
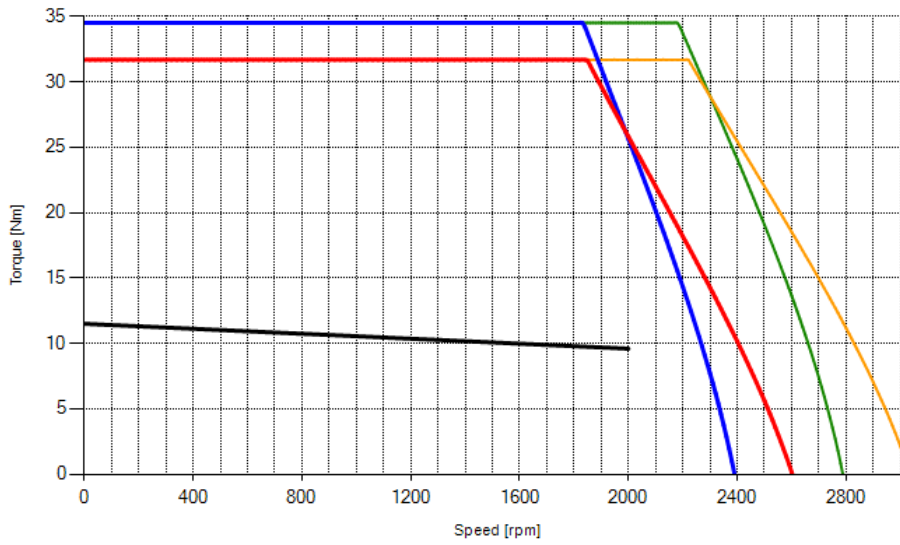

5.6.3 Curves motor series BR07

5.6.3.1 Curves BR071 – 400 V

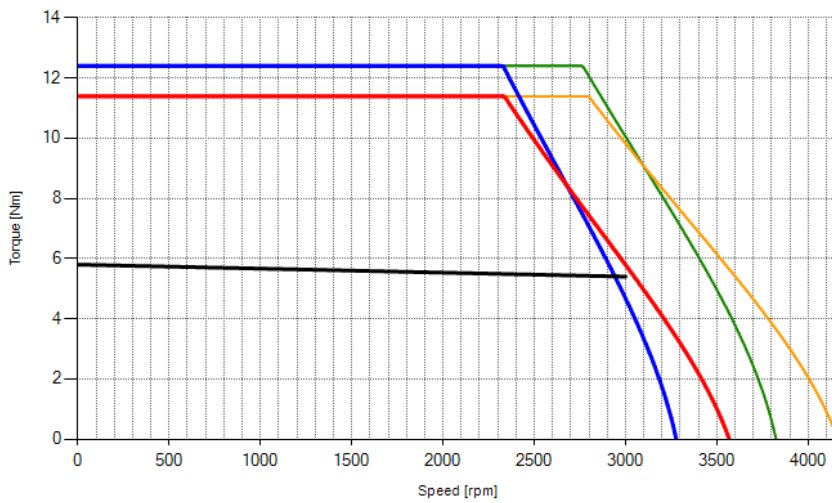
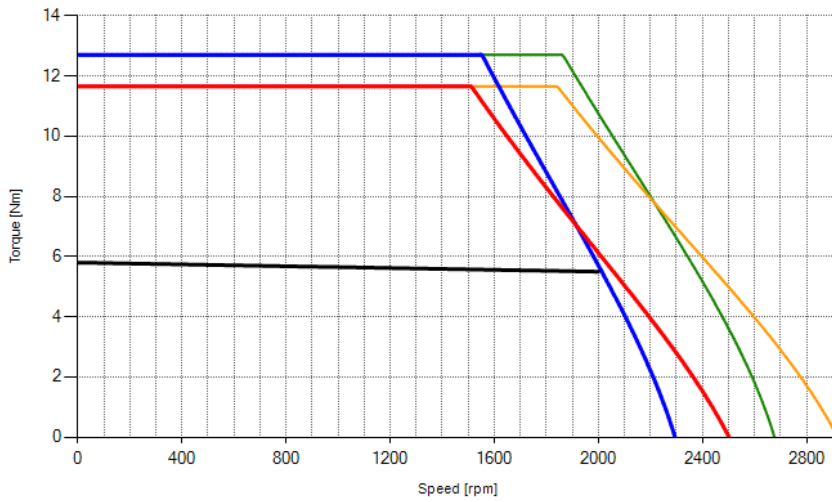
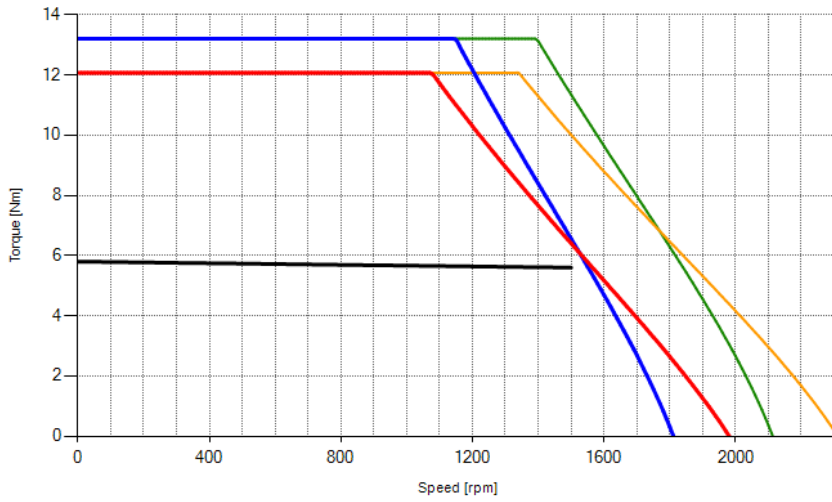

5.6.3.2 Curves BR072 – 400 V

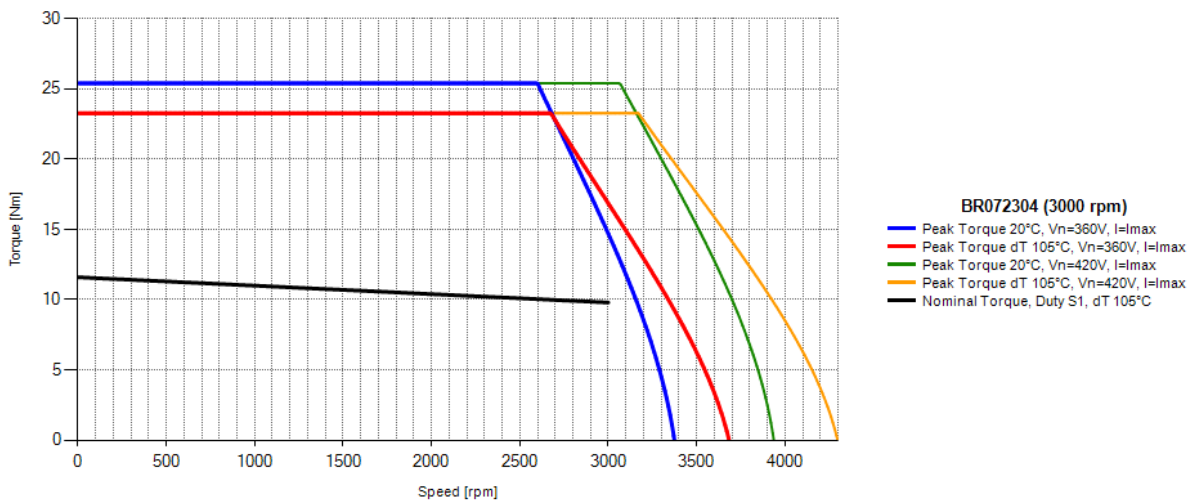
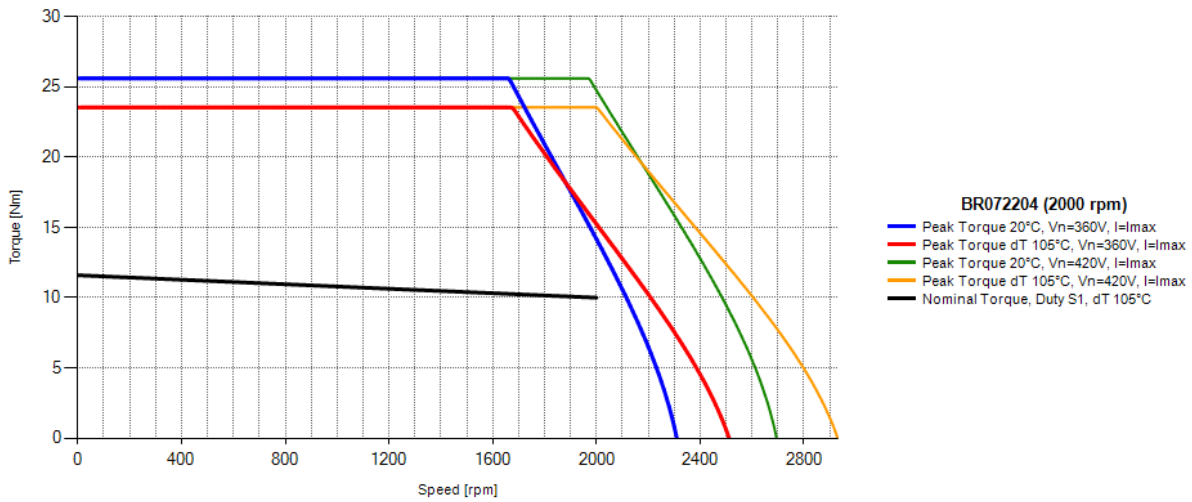
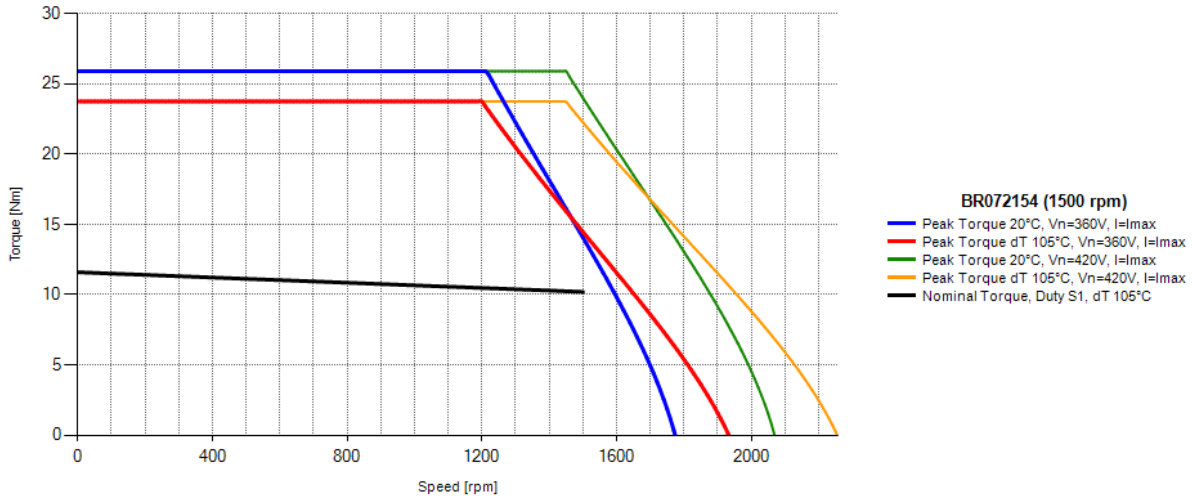

5.6.3.3 Curves BR073 – 400 V

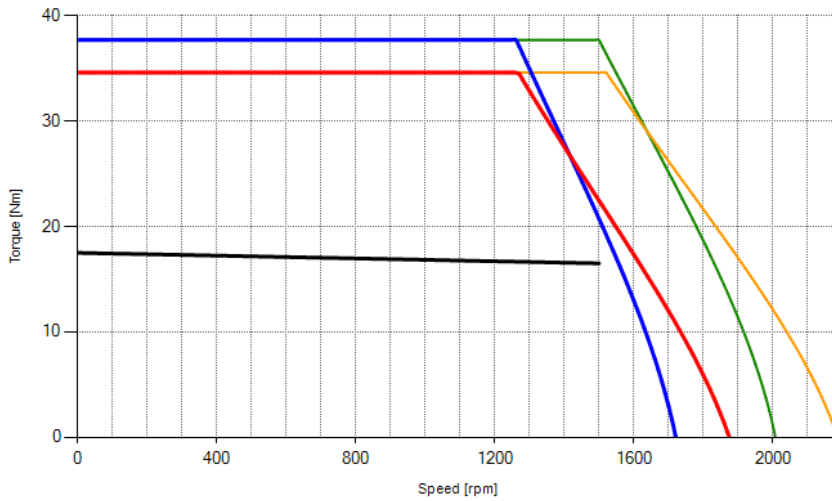

BR073154 (1500 rpm)
 — Peak Torque 20°C, Vn=360V, I=Imax
 — Peak Torque dT 105°C, Vn=360V, I=Imax
 — Peak Torque 20°C, Vn=420V, I=Imax
 — Peak Torque dT 105°C, Vn=420V, I=Imax
 — Nominal Torque, Duty S1, dT 105°C

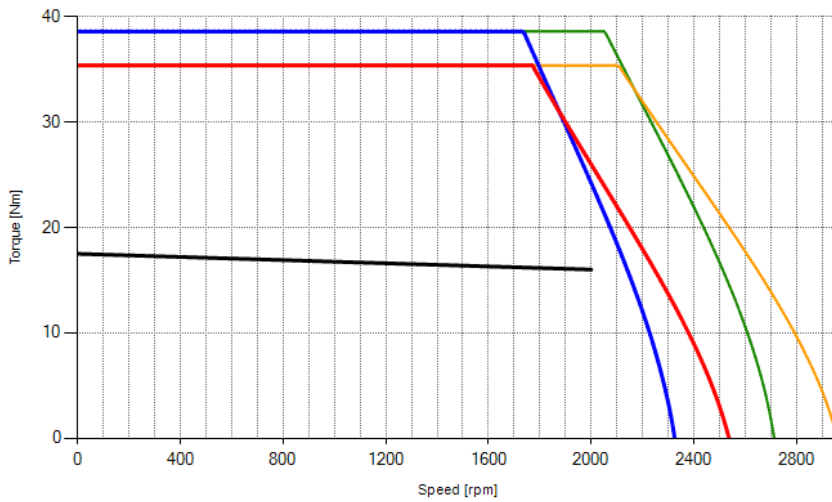

BR073204 (2000 rpm)
 — Peak Torque 20°C, Vn=360V, I=Imax
 — Peak Torque dT 105°C, Vn=360V, I=Imax
 — Peak Torque 20°C, Vn=420V, I=Imax
 — Peak Torque dT 105°C, Vn=420V, I=Imax
 — Nominal Torque, Duty S1, dT 105°C

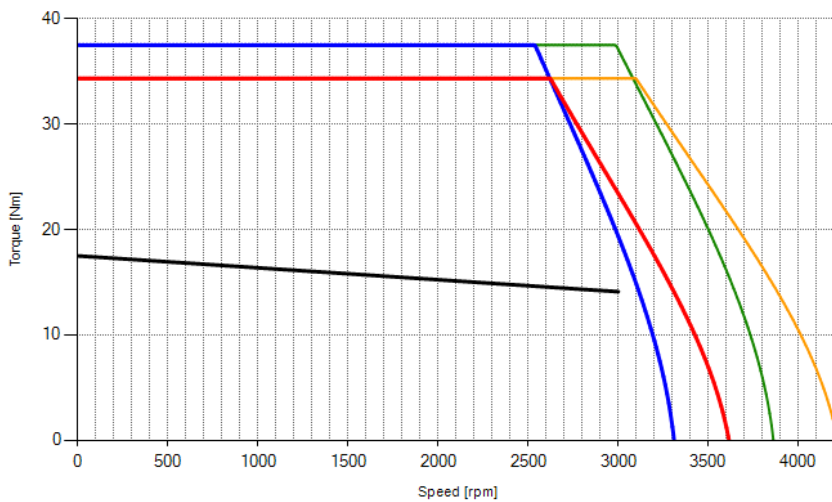

BR073304 (3000 rpm)
 — Peak Torque 20°C, Vn=360V, I=Imax
 — Peak Torque dT 105°C, Vn=360V, I=Imax
 — Peak Torque 20°C, Vn=420V, I=Imax
 — Peak Torque dT 105°C, Vn=420V, I=Imax
 — Nominal Torque, Duty S1, dT 105°C

5.6.3.4 Curves BR074 – 400 V

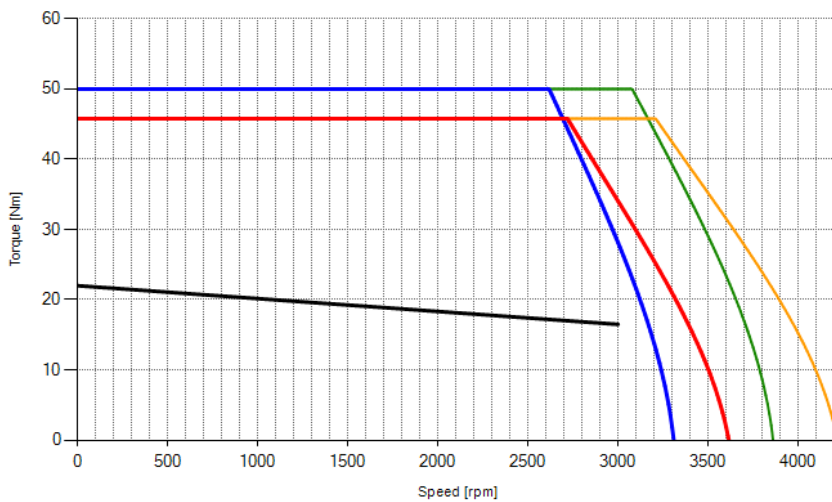
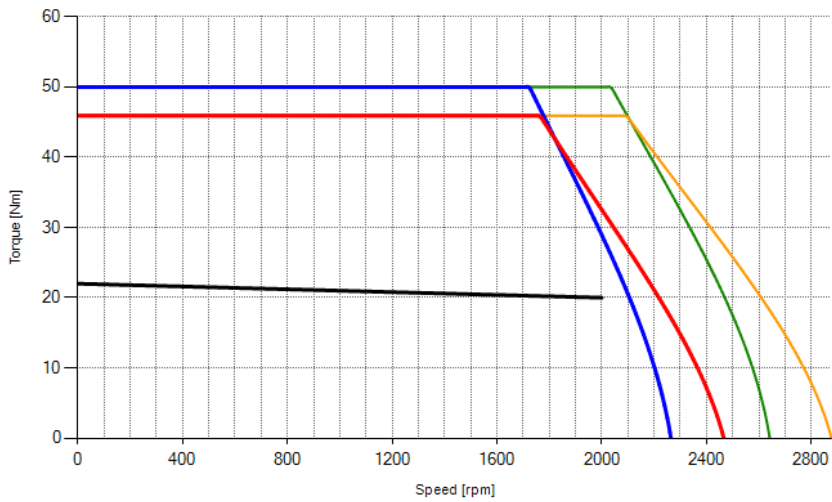
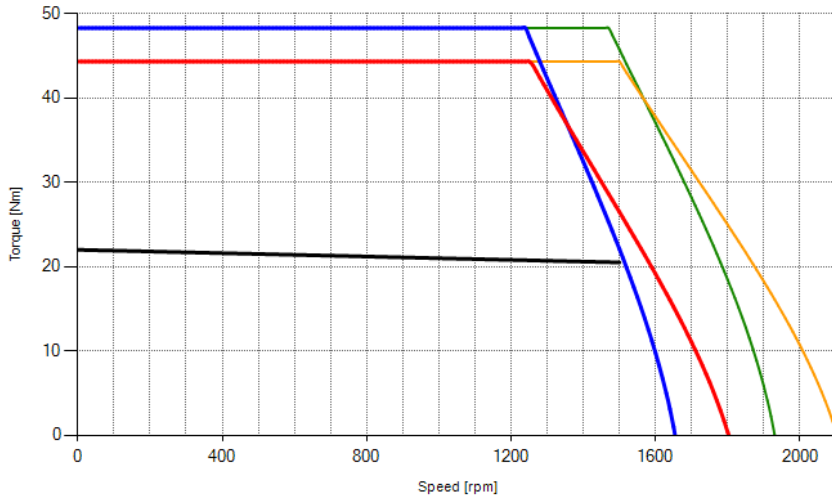

5.6.3.5 Curves BR075 – 400 V

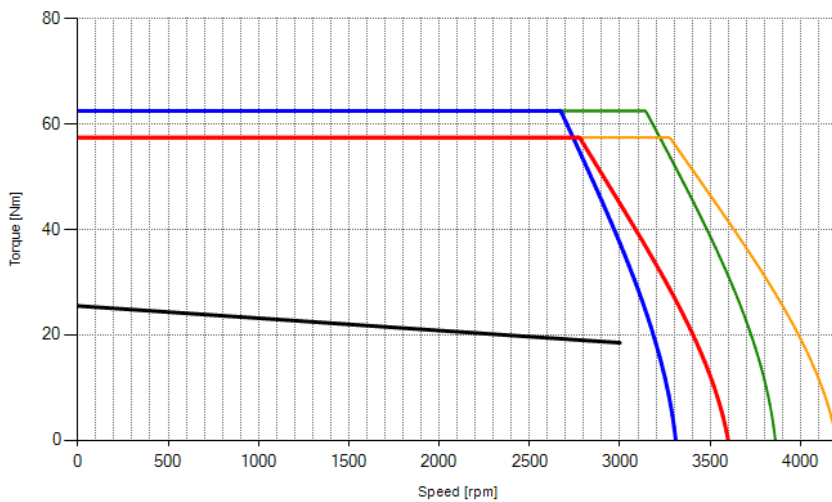
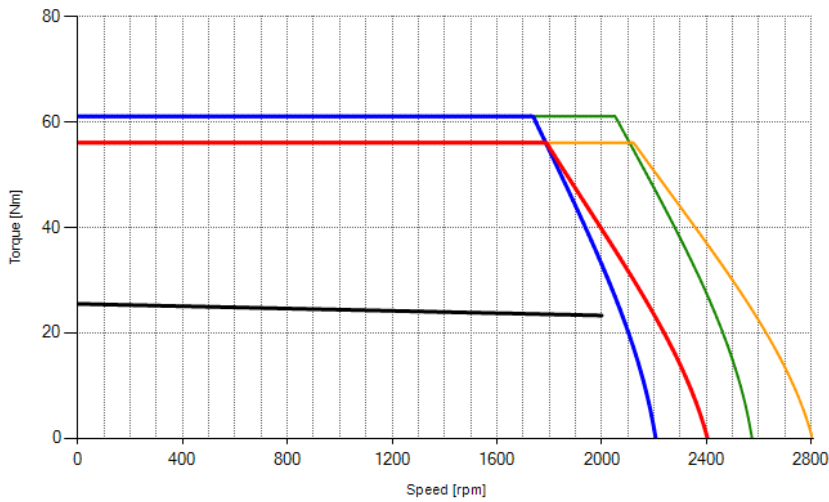
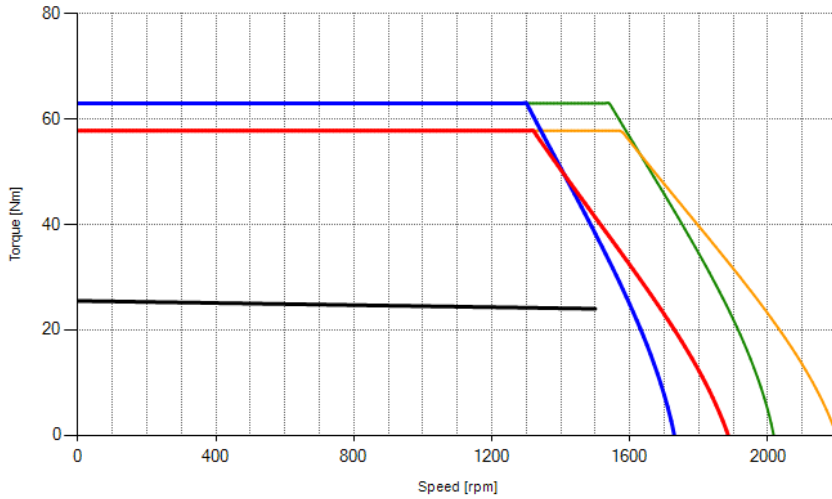

5.6.3.6 Curves BR076 – 400 V

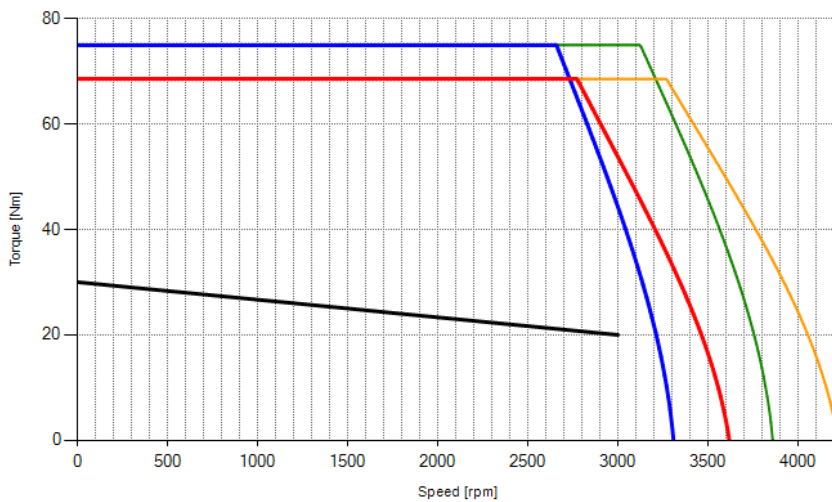
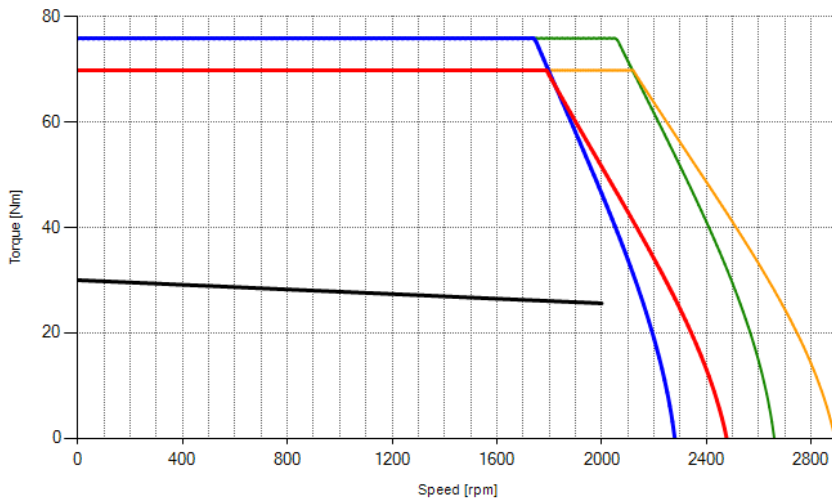
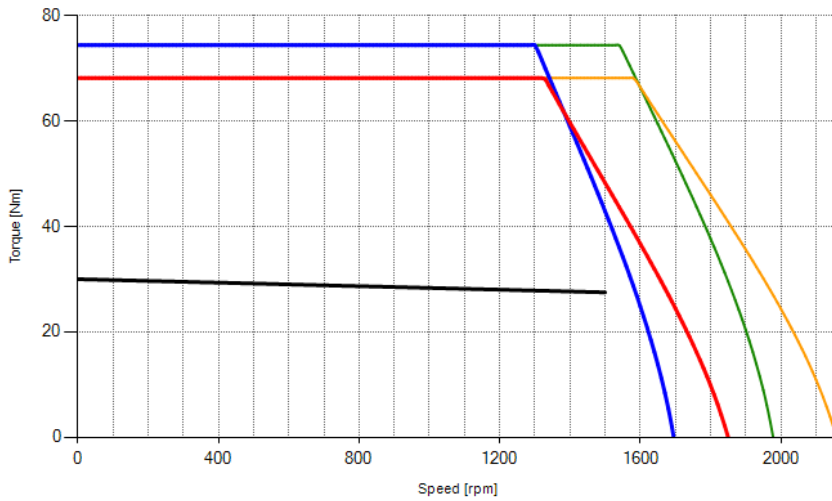

5.6.3.7 Curves BR077 – 400 V

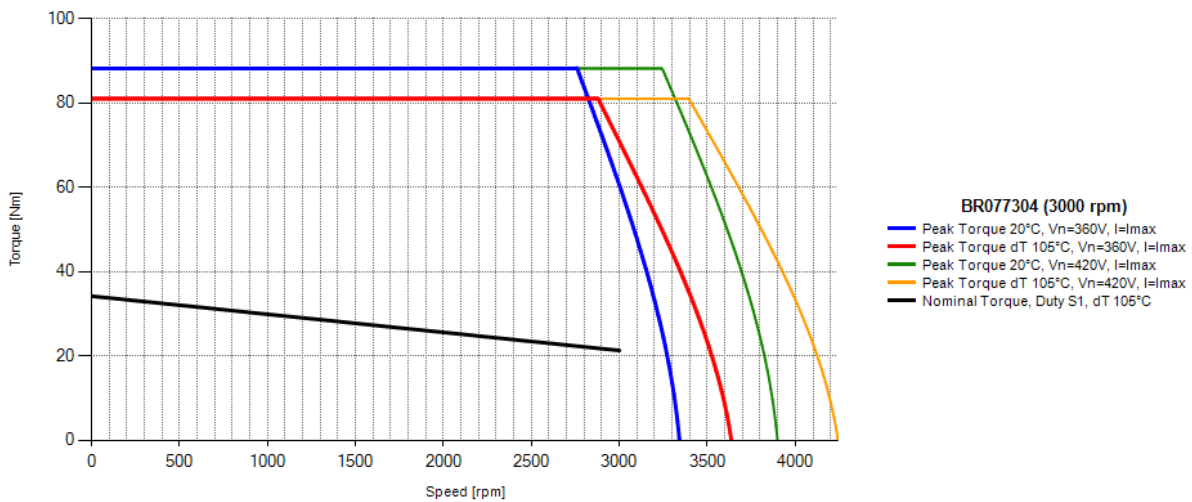
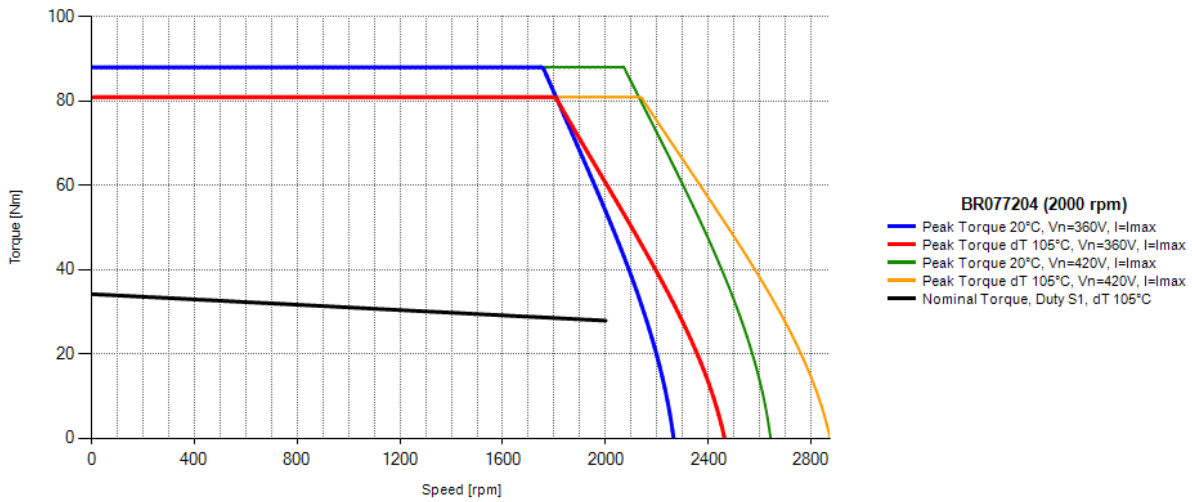
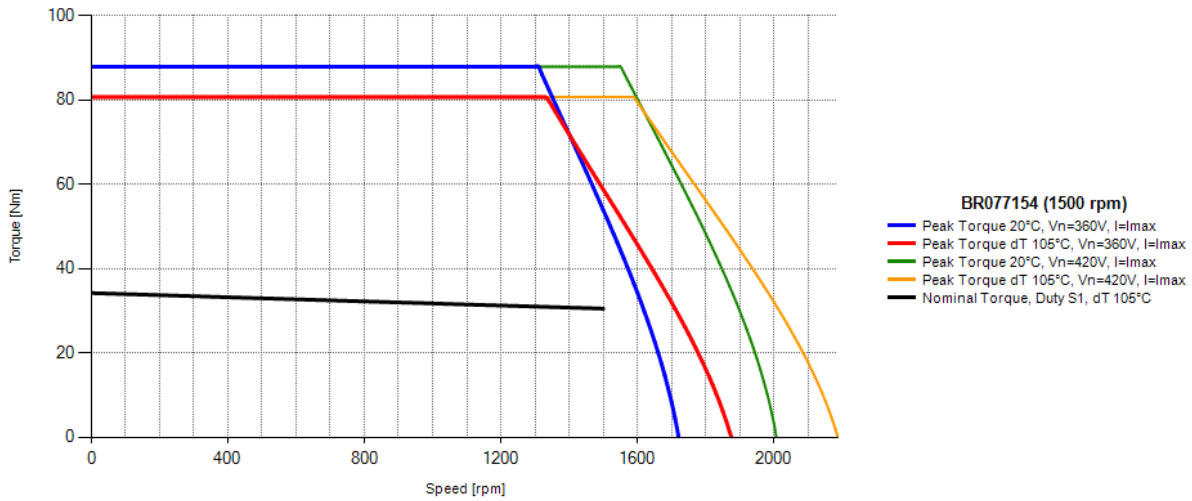

5.6.3.8 Curves BR078 – 400 V

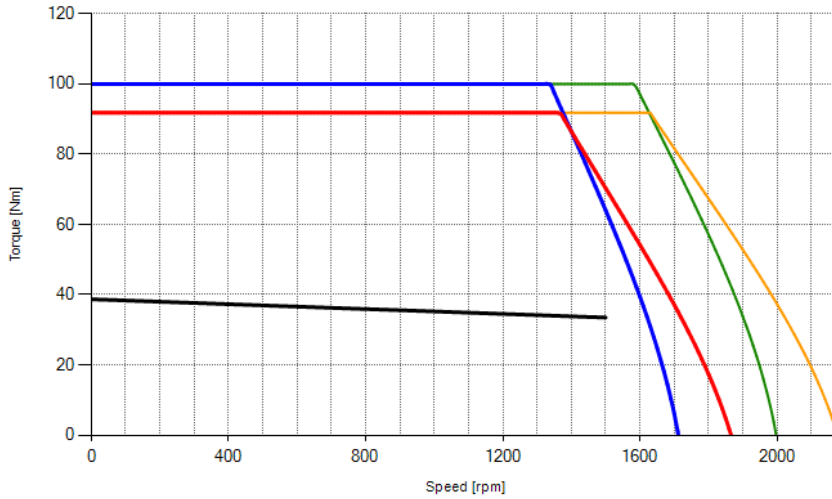

BR078154 (1500 rpm)
 — Peak Torque 20°C, Vn=360V, I=Imax
 — Peak Torque dT 105°C, Vn=360V, I=Imax
 — Peak Torque 20°C, Vn=420V, I=Imax
 — Peak Torque dT 105°C, Vn=420V, I=Imax
 — Nominal Torque, Duty S1, dT 105°C

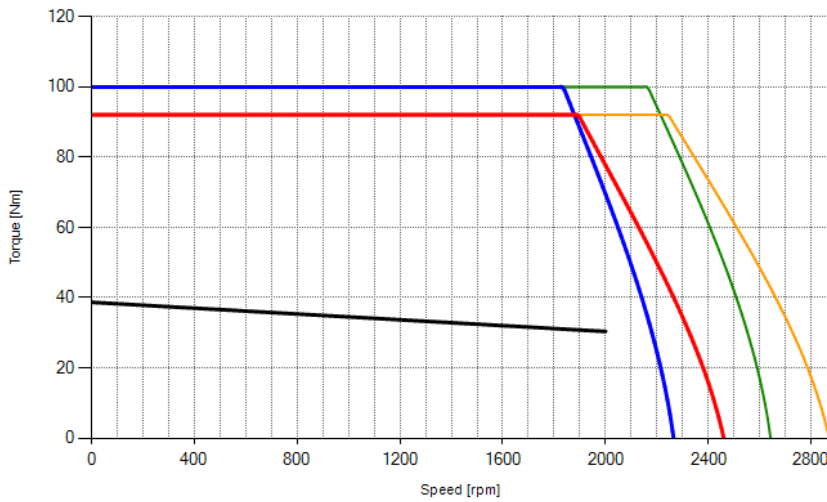

BR078204 (2000 rpm)
 — Peak Torque 20°C, Vn=360V, I=Imax
 — Peak Torque dT 105°C, Vn=360V, I=Imax
 — Peak Torque 20°C, Vn=420V, I=Imax
 — Peak Torque dT 105°C, Vn=420V, I=Imax
 — Nominal Torque, Duty S1, dT 105°C

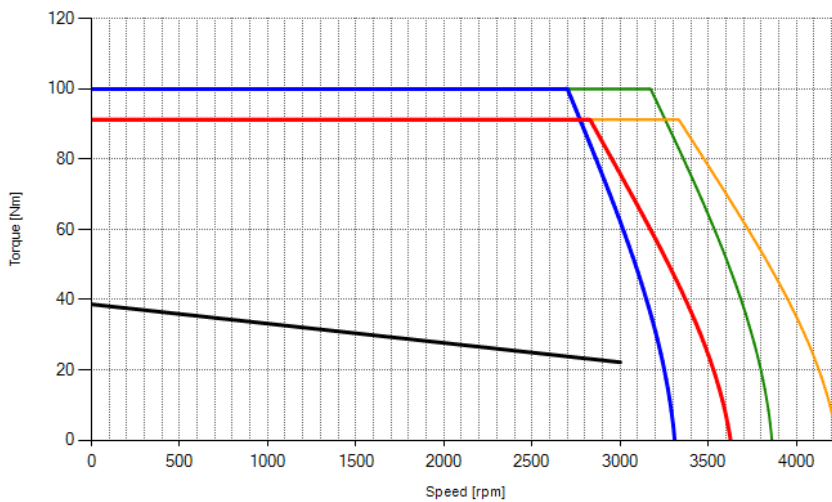

BR078304 (3000 rpm)
 — Peak Torque 20°C, Vn=360V, I=Imax
 — Peak Torque dT 105°C, Vn=360V, I=Imax
 — Peak Torque 20°C, Vn=420V, I=Imax
 — Peak Torque dT 105°C, Vn=420V, I=Imax
 — Nominal Torque, Duty S1, dT 105°C

5.6.4 Curves motor series BRV7

5.6.4.1 Curves BRV71 – 400 V

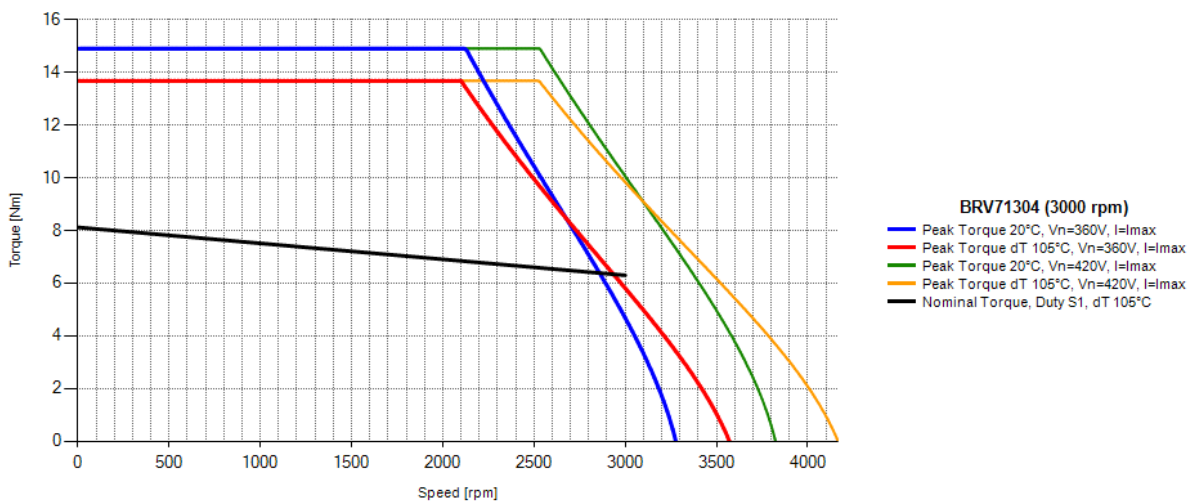
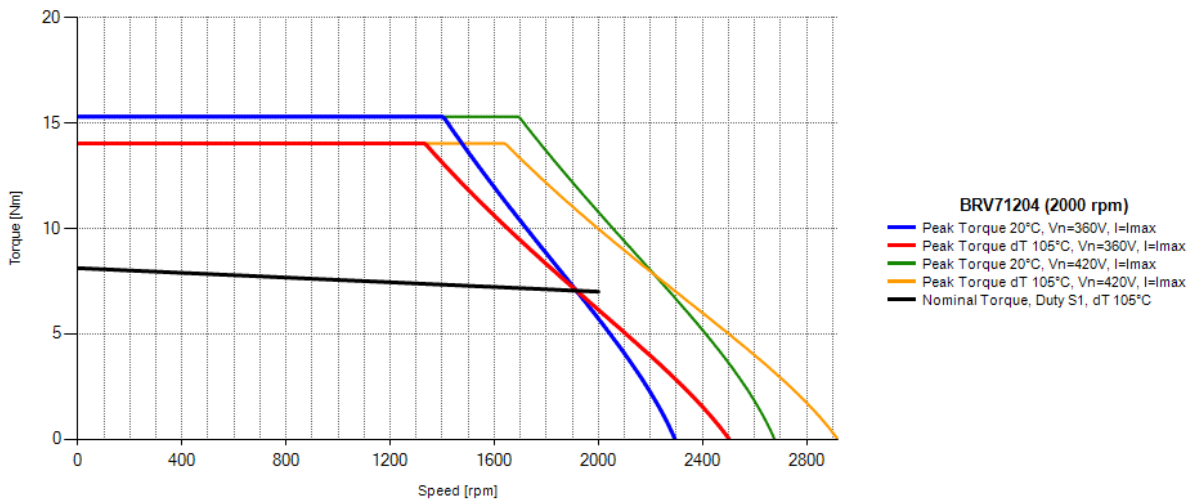
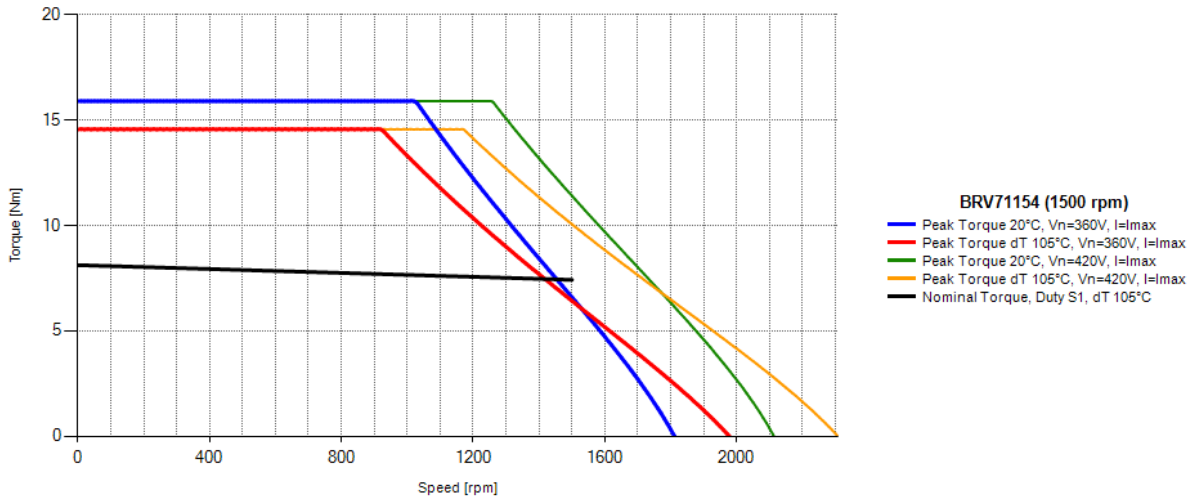

5.6.4.2 Curves BRV72 – 400 V

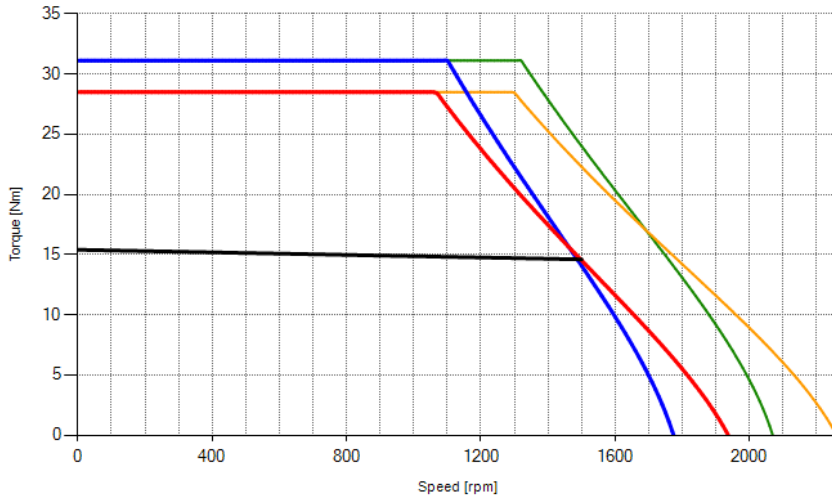

BRV72154 (1500 rpm)
 — Peak Torque 20°C, Vn=360V, I=Imax
 — Peak Torque dT 105°C, Vn=360V, I=Imax
 — Peak Torque 20°C, Vn=420V, I=Imax
 — Peak Torque dT 105°C, Vn=420V, I=Imax
 — Nominal Torque, Duty S1, dT 105°C

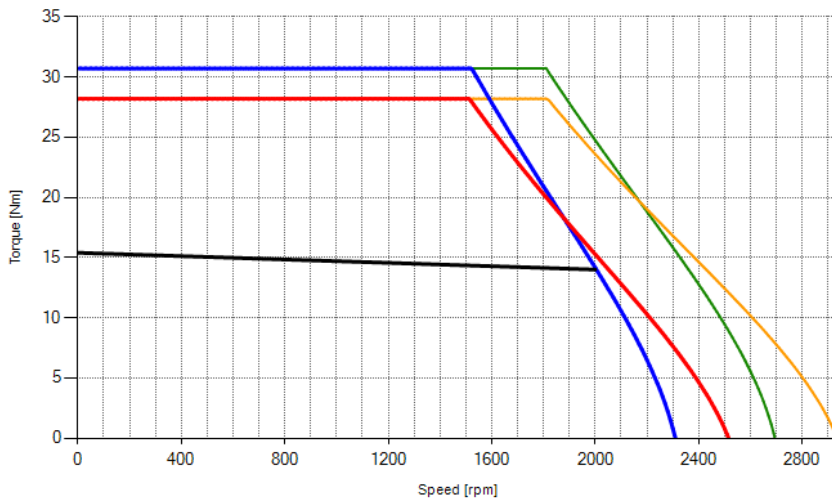

BRV72204 (2000 rpm)
 — Peak Torque 20°C, Vn=360V, I=Imax
 — Peak Torque dT 105°C, Vn=360V, I=Imax
 — Peak Torque 20°C, Vn=420V, I=Imax
 — Peak Torque dT 105°C, Vn=420V, I=Imax
 — Nominal Torque, Duty S1, dT 105°C

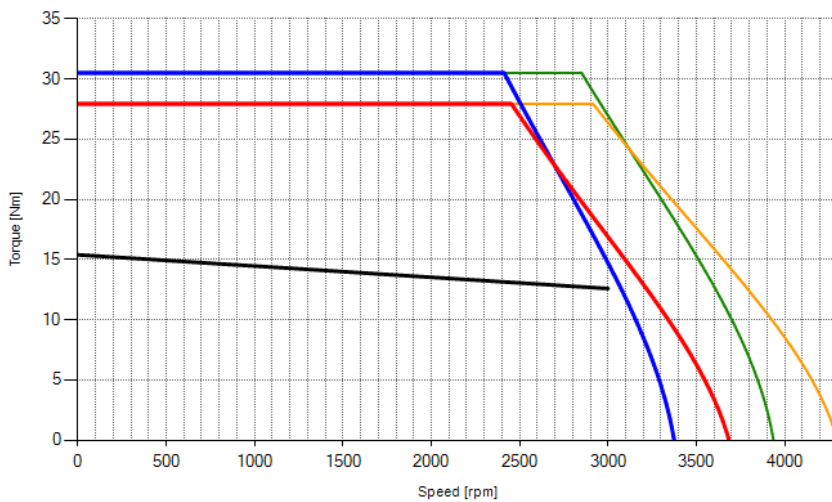

BRV72304 (3000 rpm)
 — Peak Torque 20°C, Vn=360V, I=Imax
 — Peak Torque dT 105°C, Vn=360V, I=Imax
 — Peak Torque 20°C, Vn=420V, I=Imax
 — Peak Torque dT 105°C, Vn=420V, I=Imax
 — Nominal Torque, Duty S1, dT 105°C

5.6.4.3 Curves BRV73 – 400 V

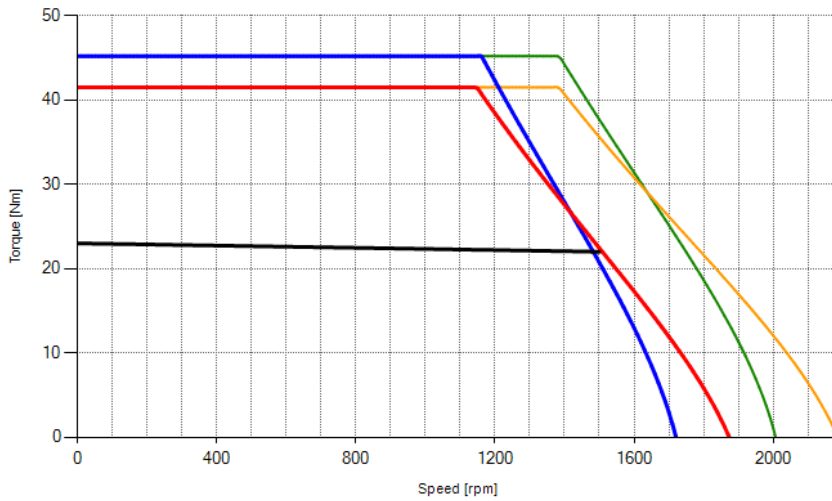

BRV73154 (1500 rpm)
 — Peak Torque 20°C, Vn=360V, I=Imax
 — Peak Torque dT 105°C, Vn=360V, I=Imax
 — Peak Torque 20°C, Vn=420V, I=Imax
 — Peak Torque dT 105°C, Vn=420V, I=Imax
 — Nominal Torque, Duty S1, dT 105°C

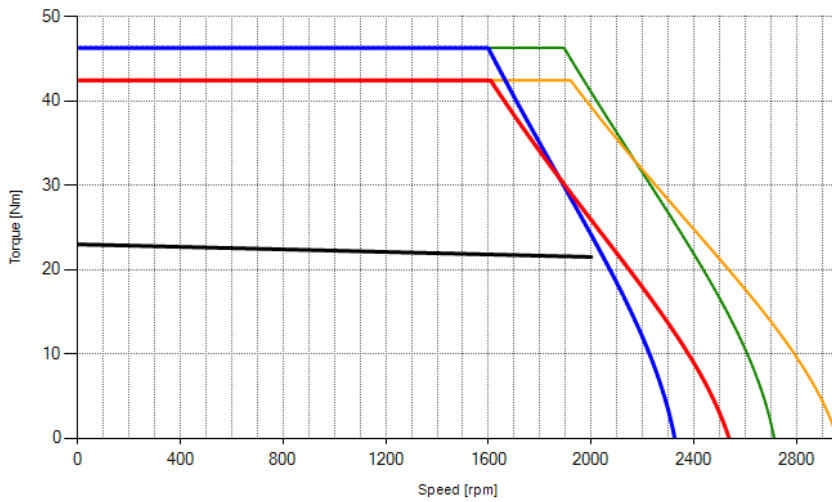

BRV73204 (2000 rpm)
 — Peak Torque 20°C, Vn=360V, I=Imax
 — Peak Torque dT 105°C, Vn=360V, I=Imax
 — Peak Torque 20°C, Vn=420V, I=Imax
 — Peak Torque dT 105°C, Vn=420V, I=Imax
 — Nominal Torque, Duty S1, dT 105°C

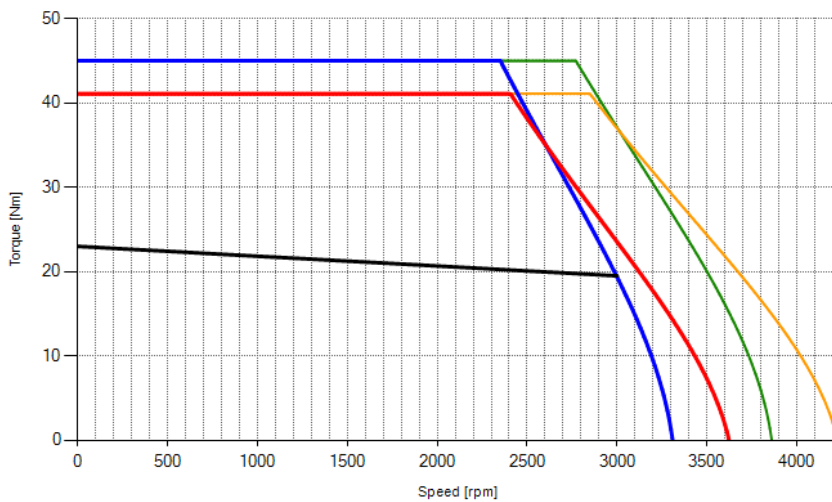

BRV73304 (3000 rpm)
 — Peak Torque 20°C, Vn=360V, I=Imax
 — Peak Torque dT 105°C, Vn=360V, I=Imax
 — Peak Torque 20°C, Vn=420V, I=Imax
 — Peak Torque dT 105°C, Vn=420V, I=Imax
 — Nominal Torque, Duty S1, dT 105°C

5.6.4.4 Curves BRV74 – 400 V

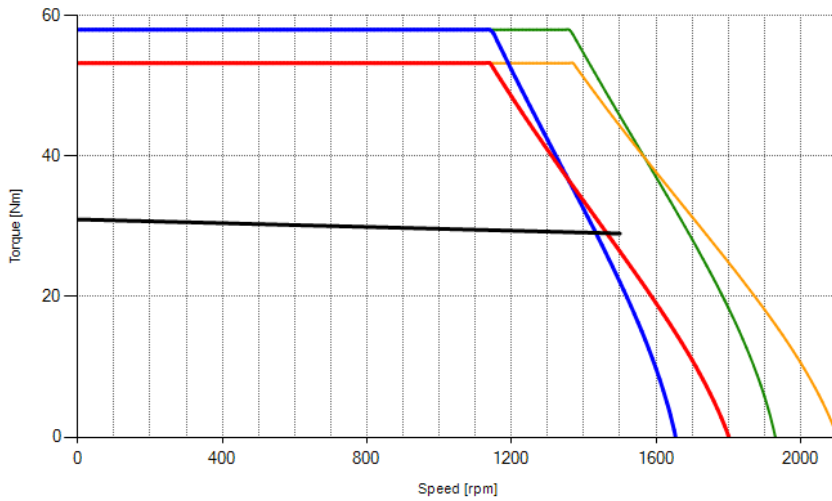

BRV74154 (1500 rpm)
 — Peak Torque 20°C, Vn=360V, I=Imax
 — Peak Torque dT 105°C, Vn=360V, I=Imax
 — Peak Torque 20°C, Vn=420V, I=Imax
 — Peak Torque dT 105°C, Vn=420V, I=Imax
 — Nominal Torque, Duty S1, dT 105°C

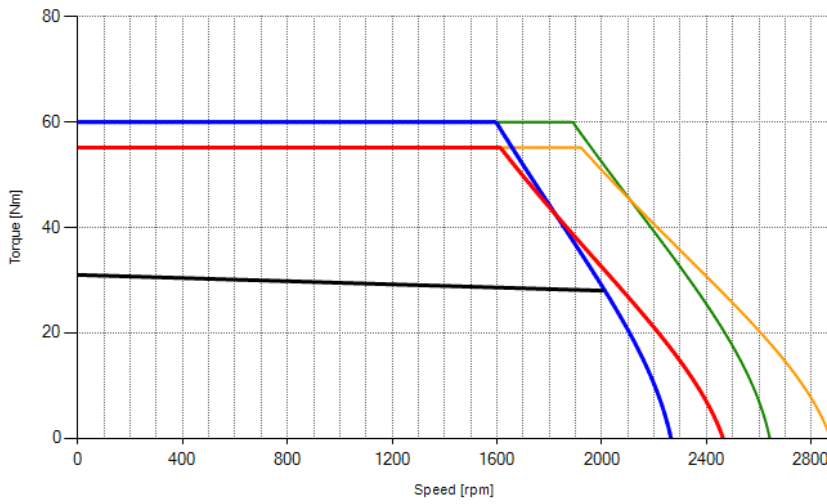

BRV74204 (2000 rpm)
 — Peak Torque 20°C, Vn=360V, I=Imax
 — Peak Torque dT 105°C, Vn=360V, I=Imax
 — Peak Torque 20°C, Vn=420V, I=Imax
 — Peak Torque dT 105°C, Vn=420V, I=Imax
 — Nominal Torque, Duty S1, dT 105°C

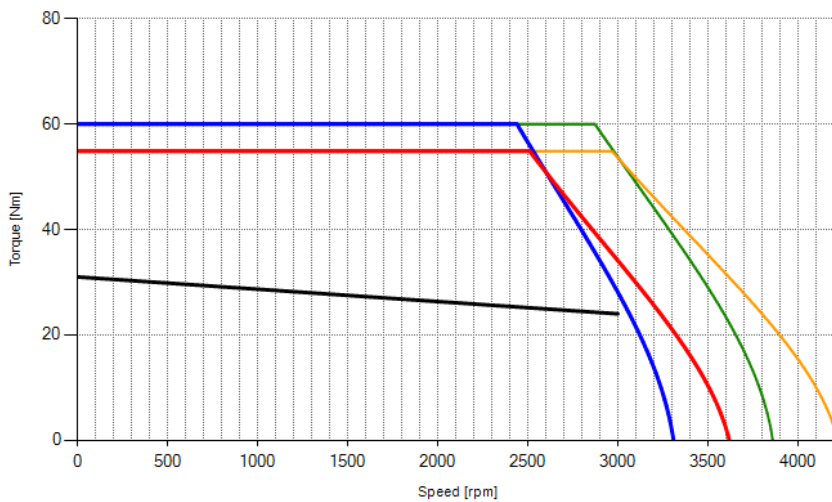

BRV74304 (3000 rpm)
 — Peak Torque 20°C, Vn=360V, I=Imax
 — Peak Torque dT 105°C, Vn=360V, I=Imax
 — Peak Torque 20°C, Vn=420V, I=Imax
 — Peak Torque dT 105°C, Vn=420V, I=Imax
 — Nominal Torque, Duty S1, dT 105°C

5.6.4.5 Curves BRV75 – 400 V

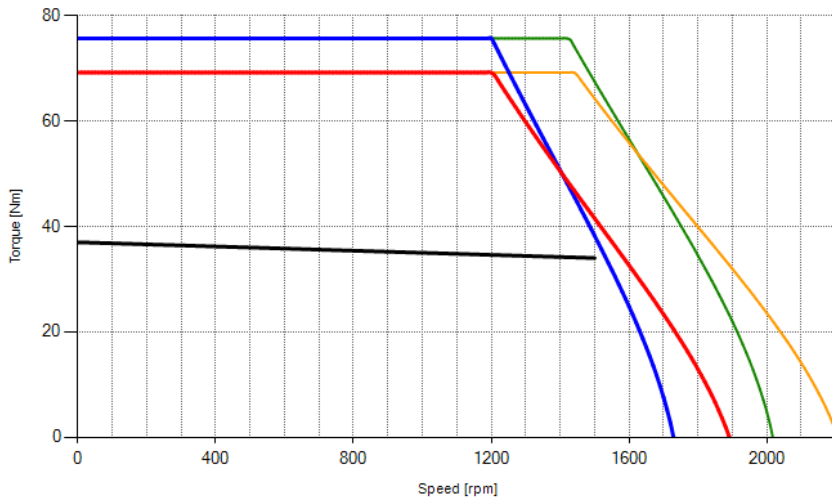

BRV75154 (1500 rpm)
 — Peak Torque 20°C, Vn=360V, I=Imax
 — Peak Torque dT 105°C, Vn=360V, I=Imax
 — Peak Torque 20°C, Vn=420V, I=Imax
 — Peak Torque dT 105°C, Vn=420V, I=Imax
 — Nominal Torque, Duty S1, dT 105°C

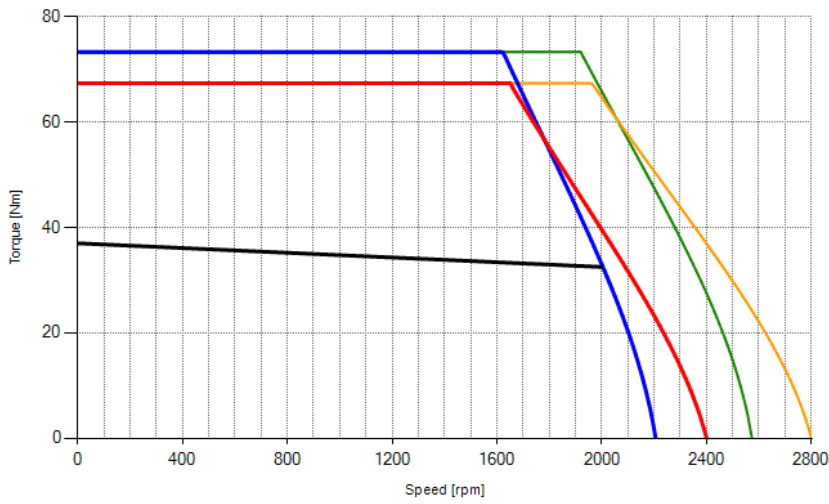

BRV75204 (2000 rpm)
 — Peak Torque 20°C, Vn=360V, I=Imax
 — Peak Torque dT 105°C, Vn=360V, I=Imax
 — Peak Torque 20°C, Vn=420V, I=Imax
 — Peak Torque dT 105°C, Vn=420V, I=Imax
 — Nominal Torque, Duty S1, dT 105°C

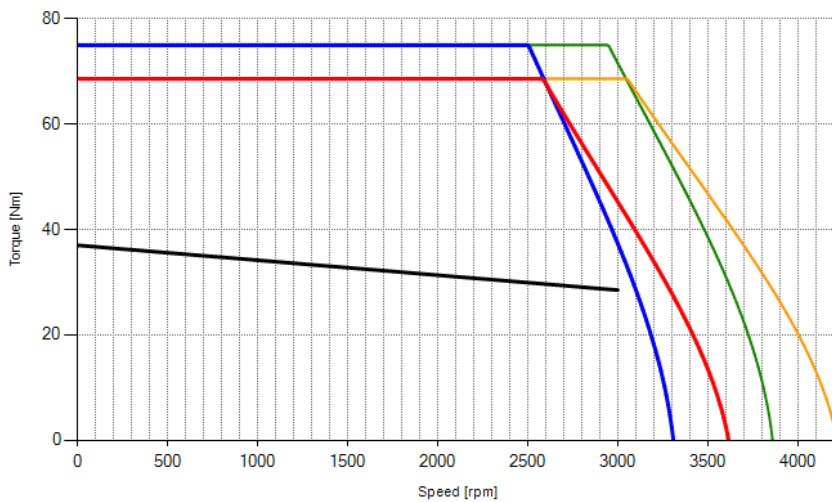

BRV75304 (3000 rpm)
 — Peak Torque 20°C, Vn=360V, I=Imax
 — Peak Torque dT 105°C, Vn=360V, I=Imax
 — Peak Torque 20°C, Vn=420V, I=Imax
 — Peak Torque dT 105°C, Vn=420V, I=Imax
 — Nominal Torque, Duty S1, dT 105°C

5.6.4.6 Curves BRV76 – 400 V

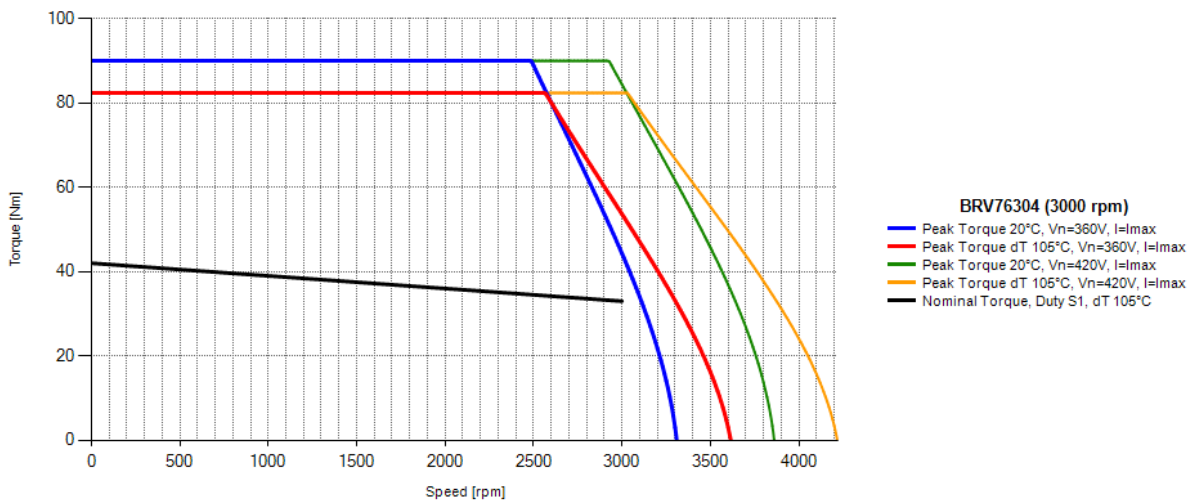
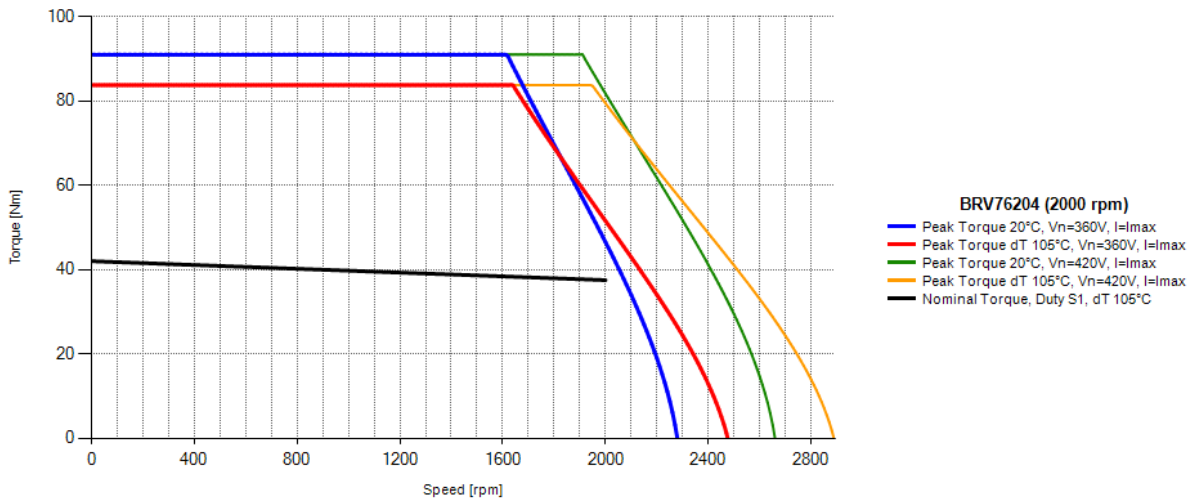
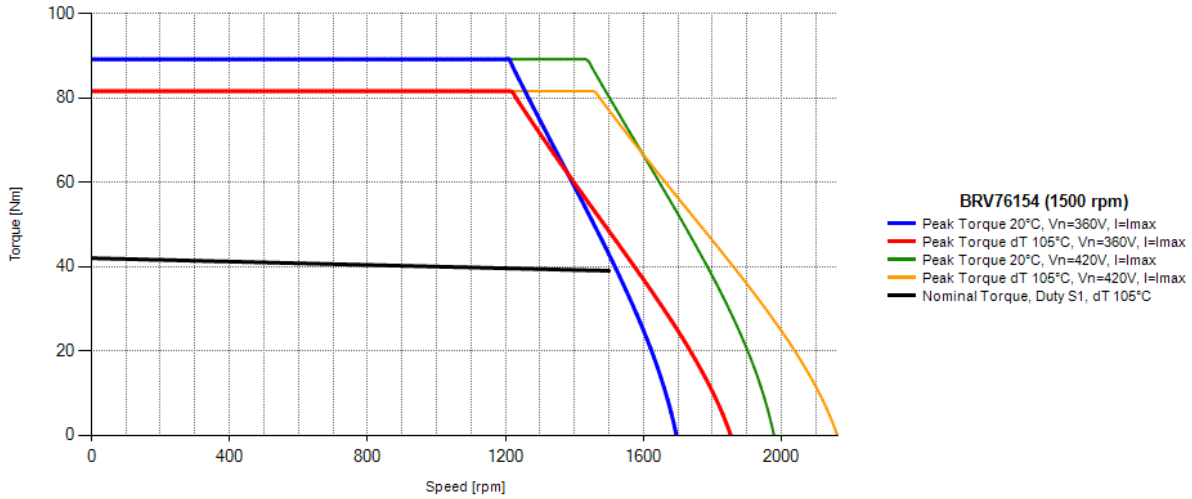

5.6.4.7 Curves BRV77 – 400 V

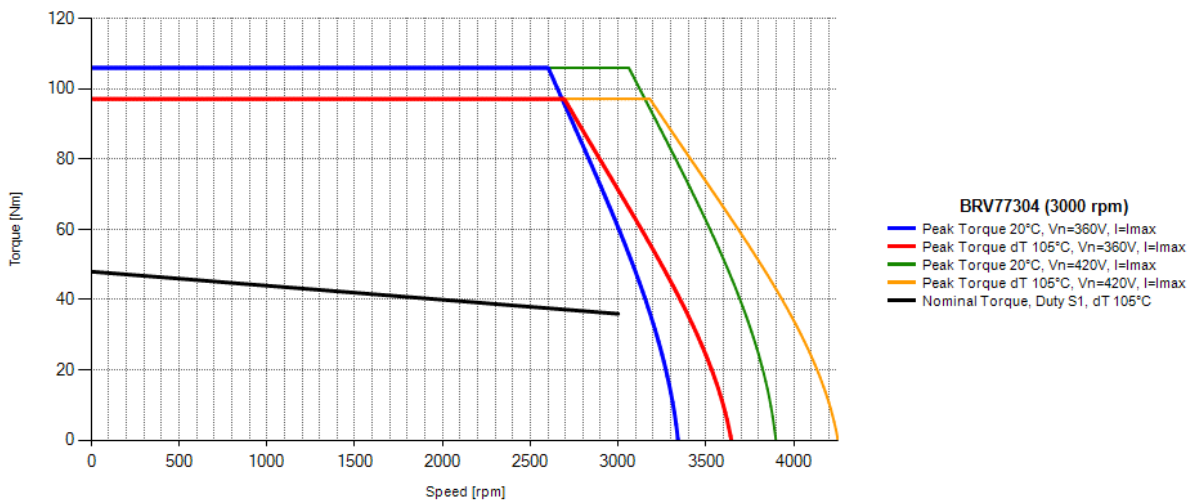
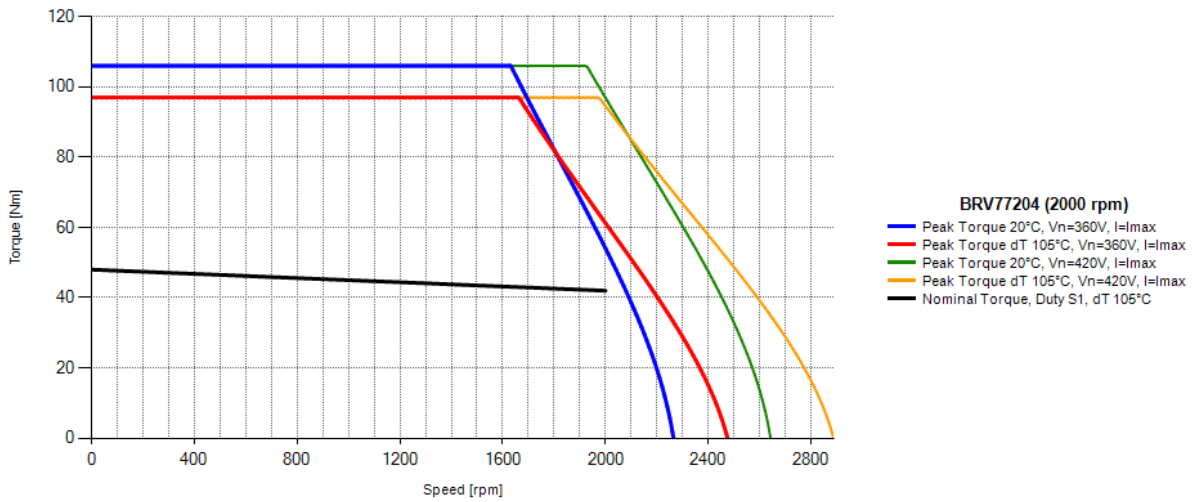
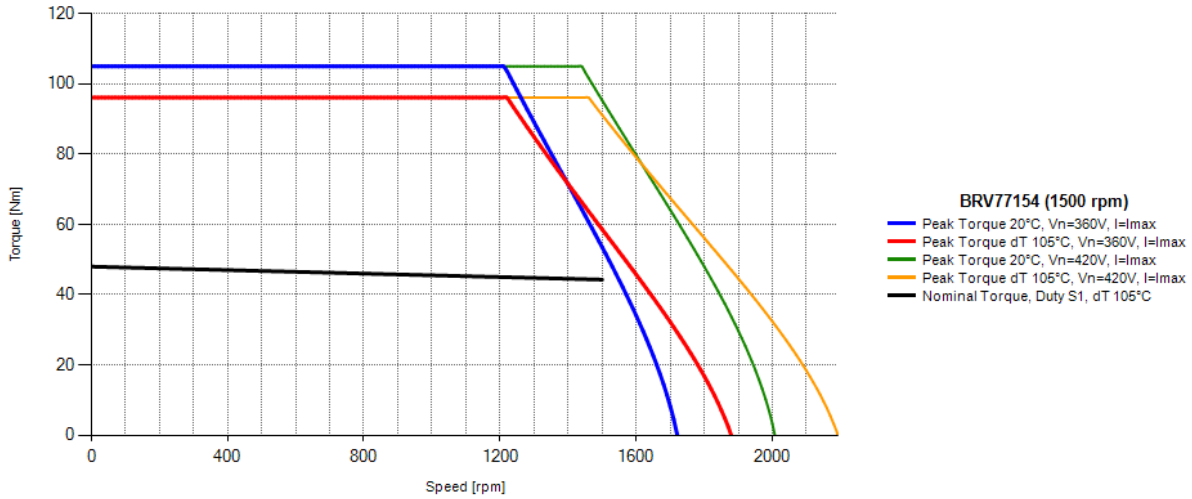

5.6.4.8 Curves BRV78 – 400 V

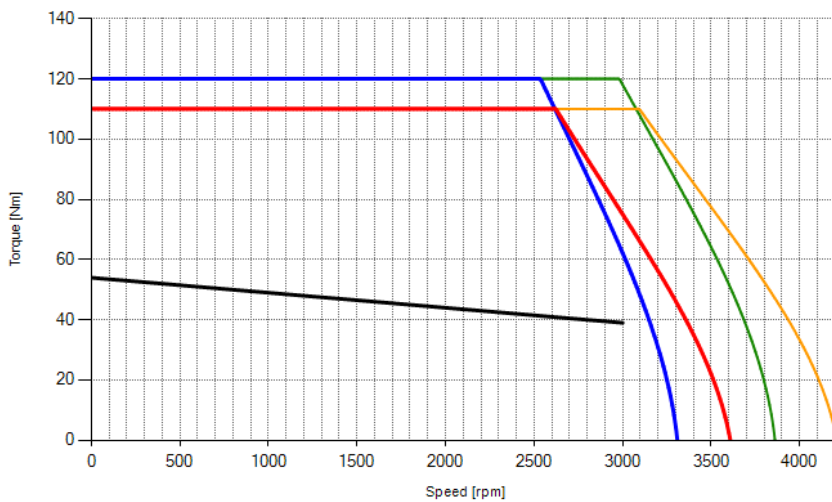
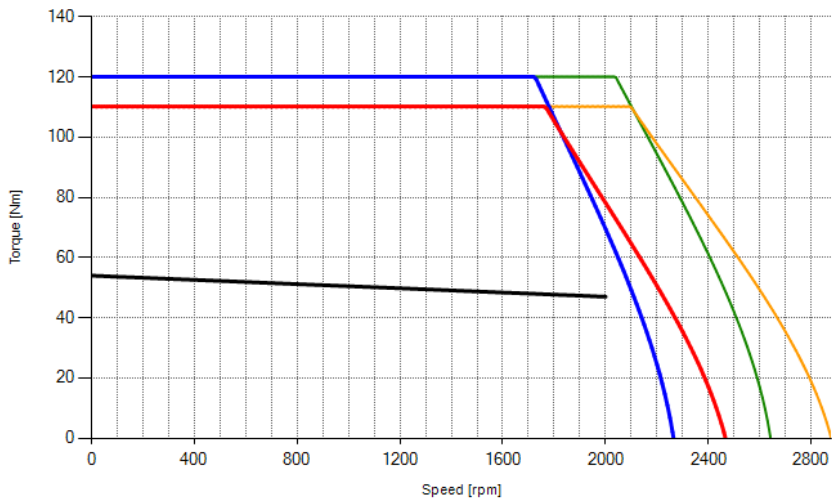
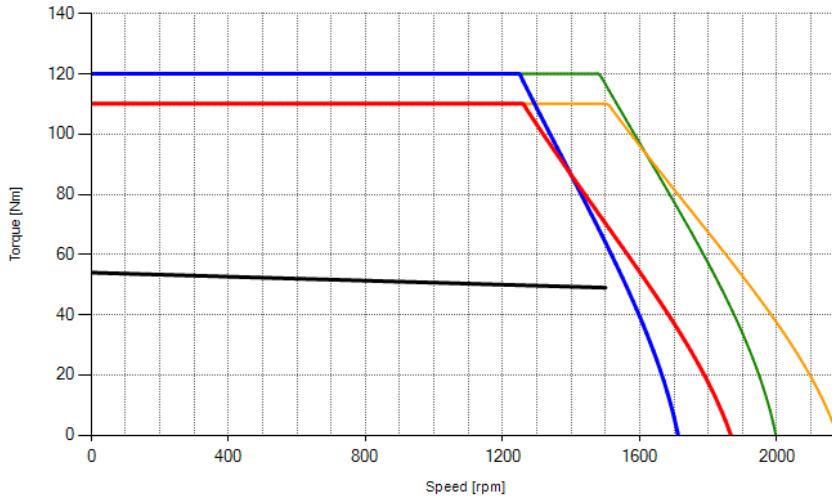

5.6.5 Curves motori serie BR08

5.6.5.1 Curves BR082 – 400 V

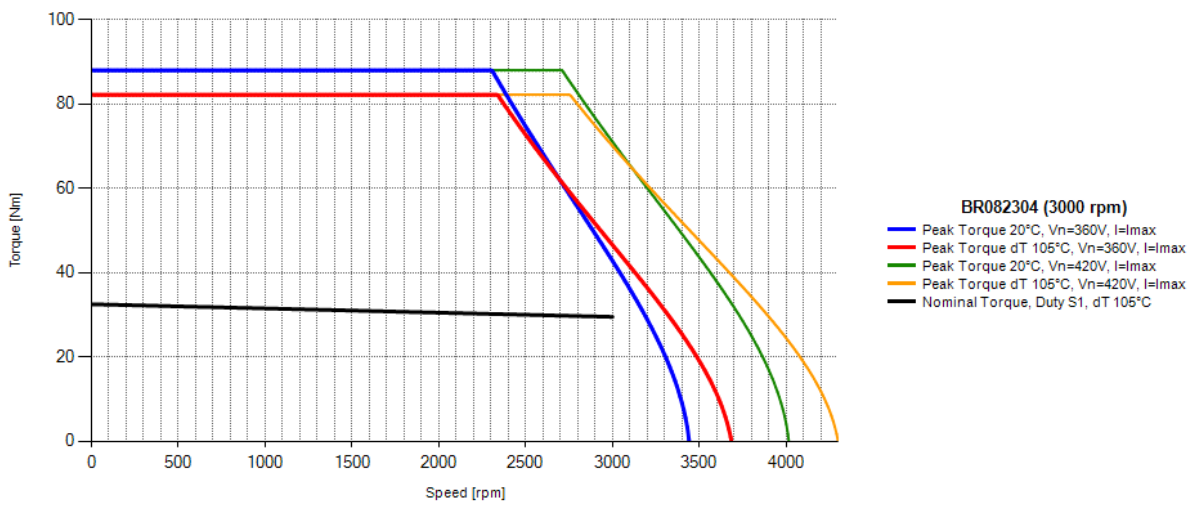
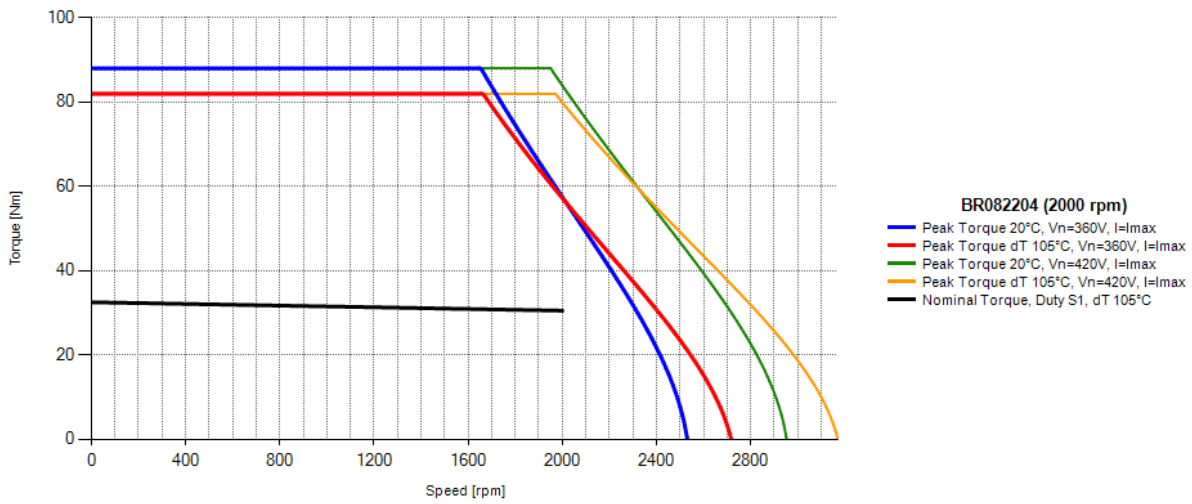
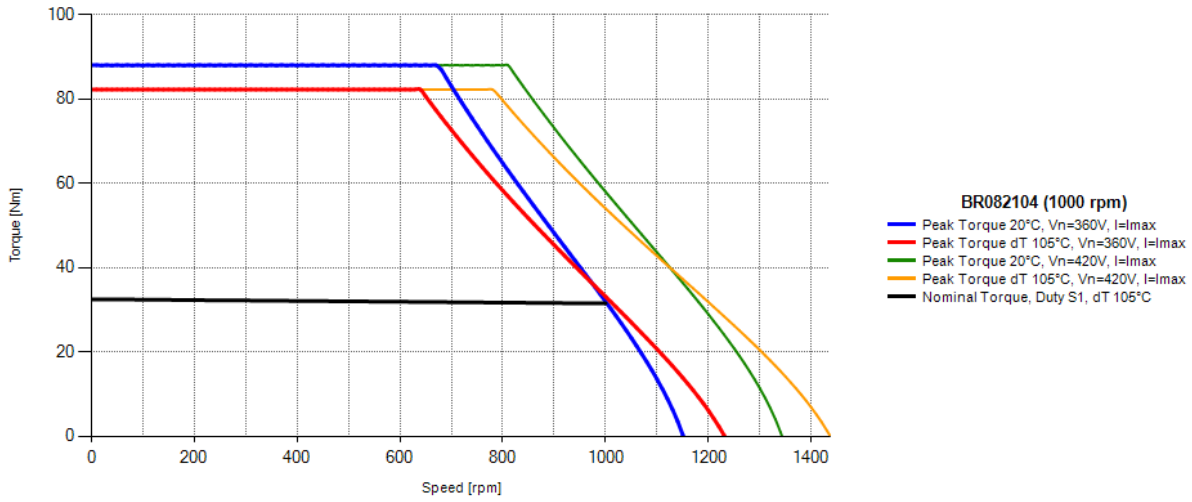

5.6.5.2 Curves BR084 – 400 V

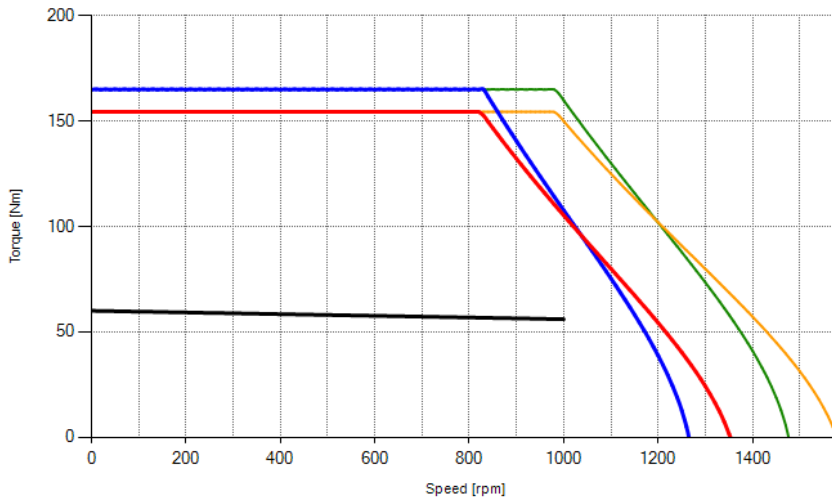

BR084104 (1000 rpm)
 — Peak Torque 20°C, Vn=360V, I=Imax
 — Peak Torque dT 105°C, Vn=360V, I=Imax
 — Peak Torque 20°C, Vn=420V, I=Imax
 — Peak Torque dT 105°C, Vn=420V, I=Imax
 — Nominal Torque, Duty S1, dT 105°C

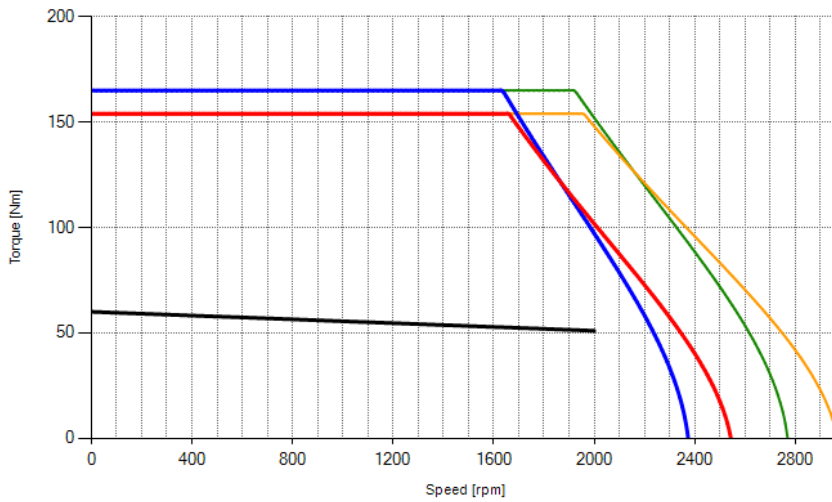

BR084204 (2000 rpm)
 — Peak Torque 20°C, Vn=360V, I=Imax
 — Peak Torque dT 105°C, Vn=360V, I=Imax
 — Peak Torque 20°C, Vn=420V, I=Imax
 — Peak Torque dT 105°C, Vn=420V, I=Imax
 — Nominal Torque, Duty S1, dT 105°C

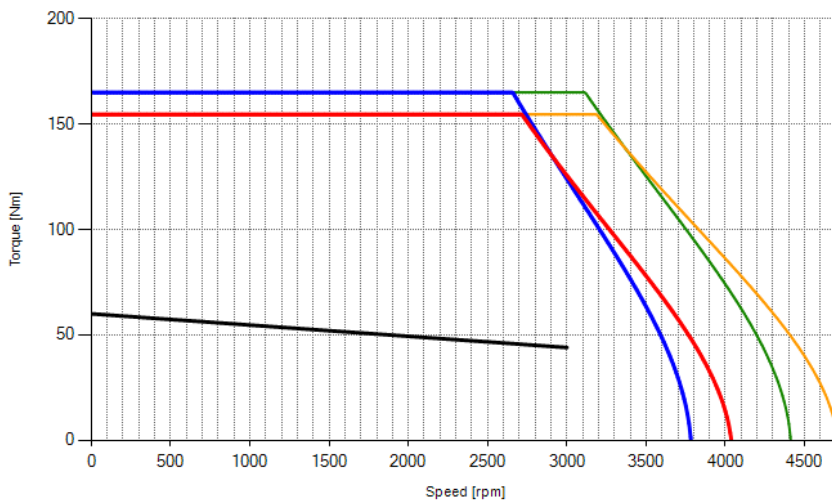

BR084304 (3000 rpm)
 — Peak Torque 20°C, Vn=360V, I=Imax
 — Peak Torque dT 105°C, Vn=360V, I=Imax
 — Peak Torque 20°C, Vn=420V, I=Imax
 — Peak Torque dT 105°C, Vn=420V, I=Imax
 — Nominal Torque, Duty S1, dT 105°C

5.6.5.3 Curves BR086 – 400 V

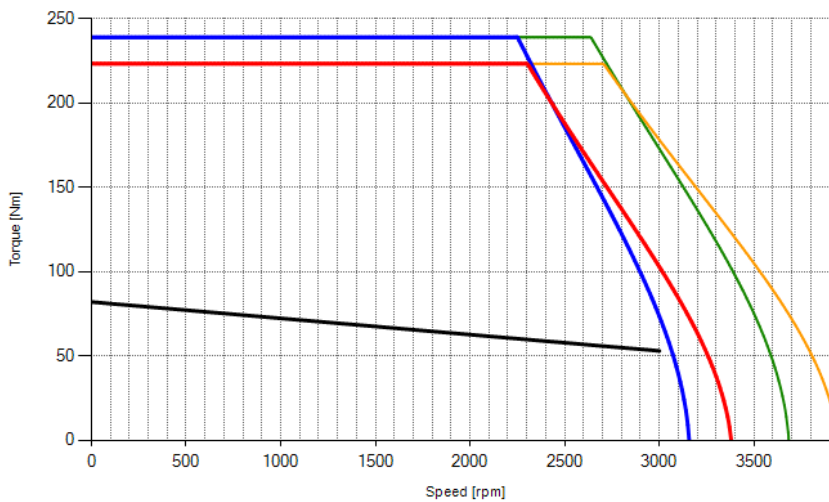
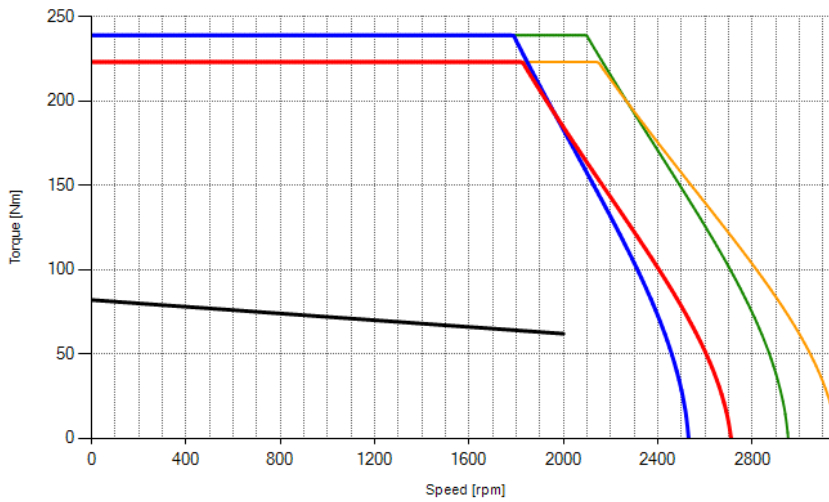
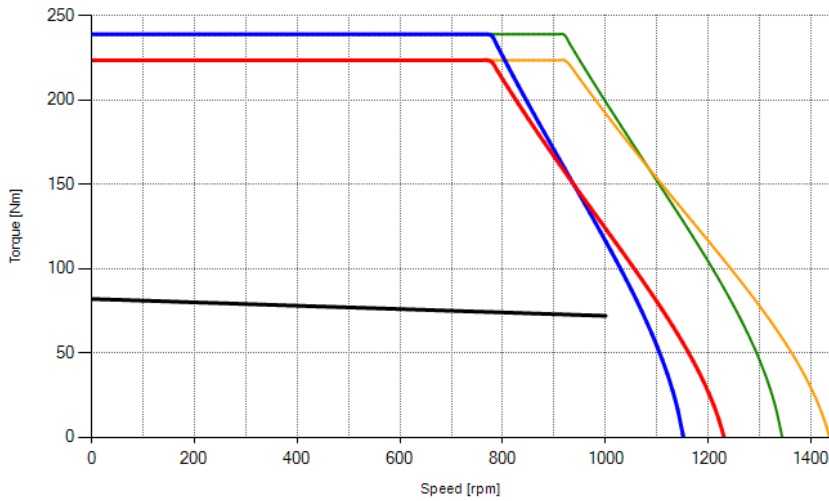

5.6.5.4 Curves BR088 – 400 V

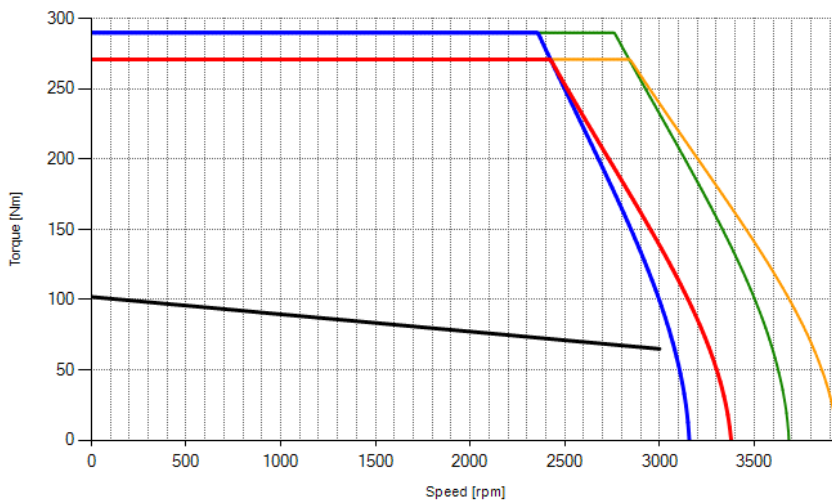
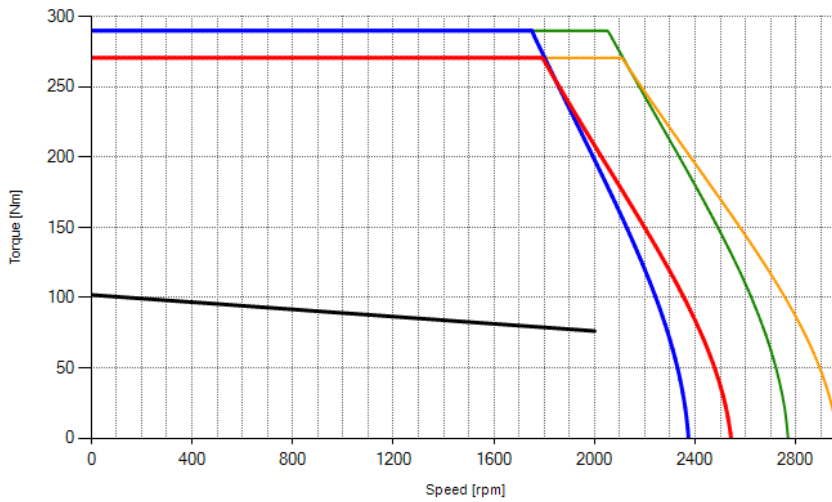
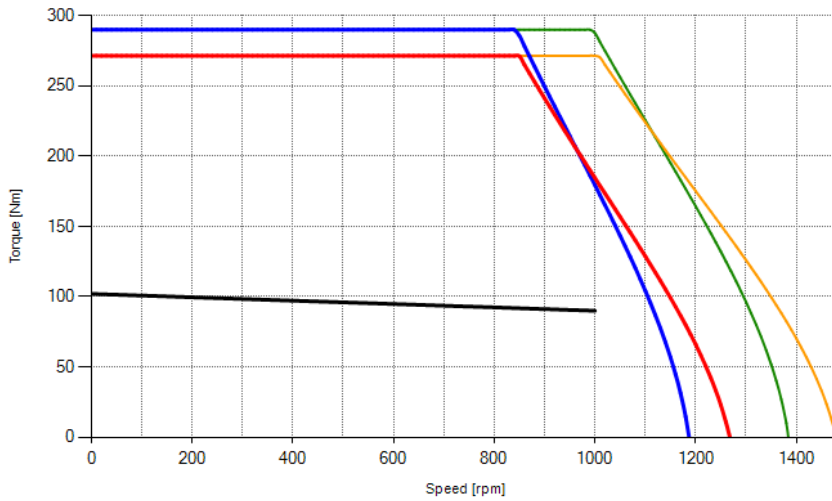

5.6.6 Curves motori serie BRV8

5.6.6.1 Curves BRV82 – 400 V

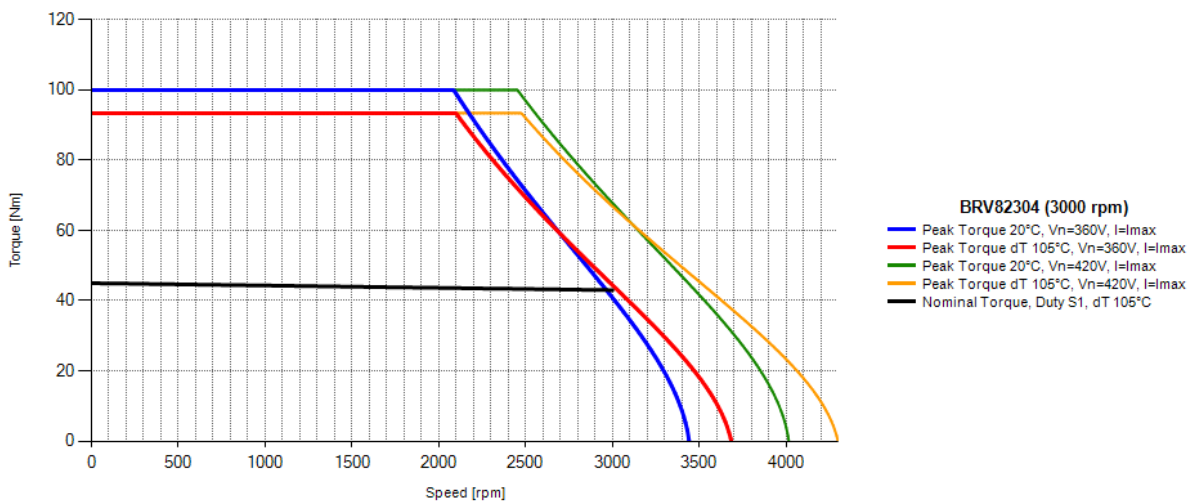
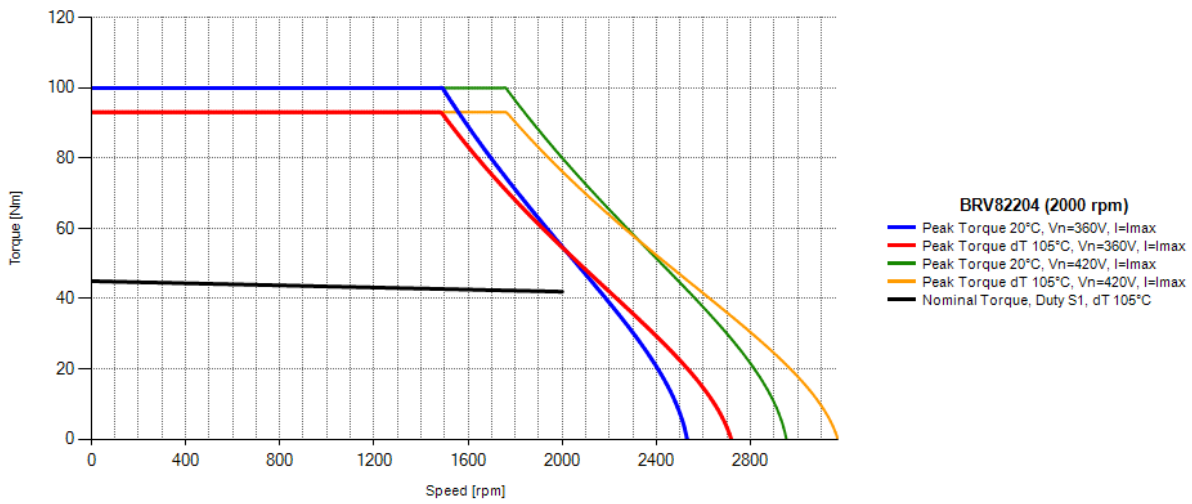
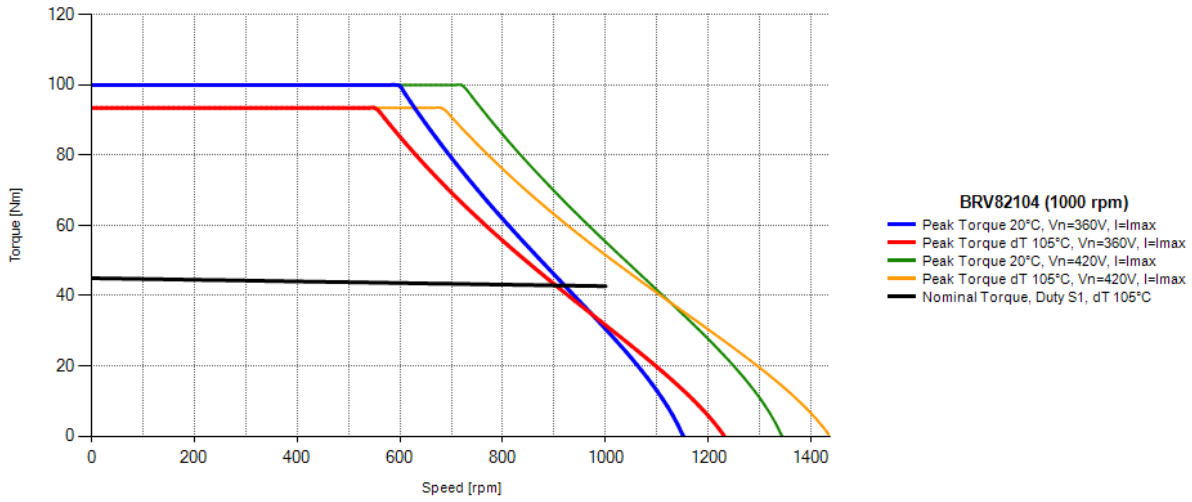

5.6.6.2 Curves BRV84 – 400 V

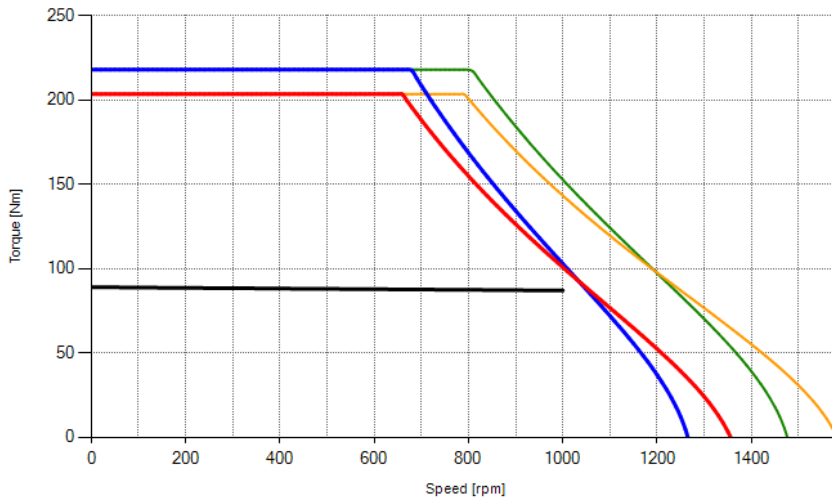

BRV84104 (1000 rpm)
 — Peak Torque 20°C, Vn=360V, I=Imax
 — Peak Torque dT 105°C, Vn=360V, I=Imax
 — Peak Torque 20°C, Vn=420V, I=Imax
 — Peak Torque dT 105°C, Vn=420V, I=Imax
 — Nominal Torque, Duty S1, dT 105°C

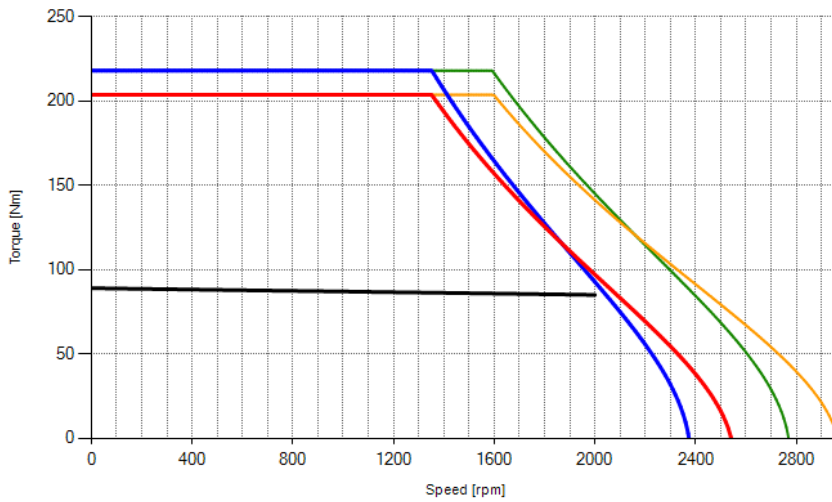

BRV84204 (2000 rpm)
 — Peak Torque 20°C, Vn=360V, I=Imax
 — Peak Torque dT 105°C, Vn=360V, I=Imax
 — Peak Torque 20°C, Vn=420V, I=Imax
 — Peak Torque dT 105°C, Vn=420V, I=Imax
 — Nominal Torque, Duty S1, dT 105°C

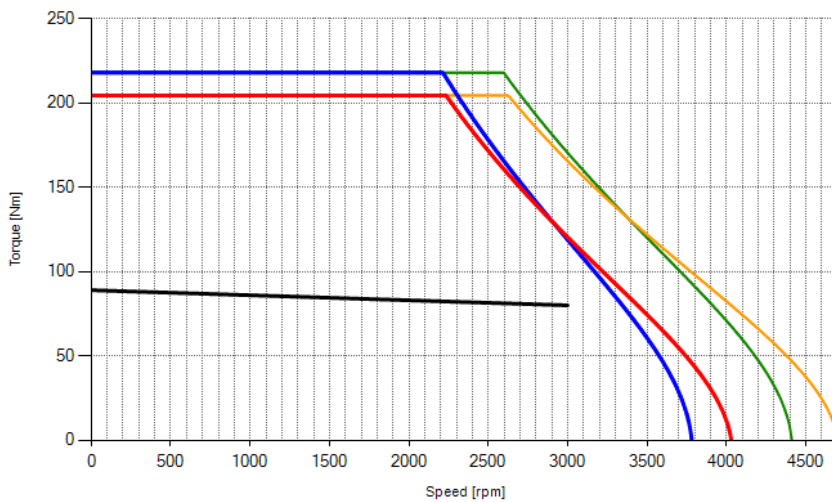

BRV84304 (3000 rpm)
 — Peak Torque 20°C, Vn=360V, I=Imax
 — Peak Torque dT 105°C, Vn=360V, I=Imax
 — Peak Torque 20°C, Vn=420V, I=Imax
 — Peak Torque dT 105°C, Vn=420V, I=Imax
 — Nominal Torque, Duty S1, dT 105°C

5.6.6.3 Curves BRV86 – 400 V

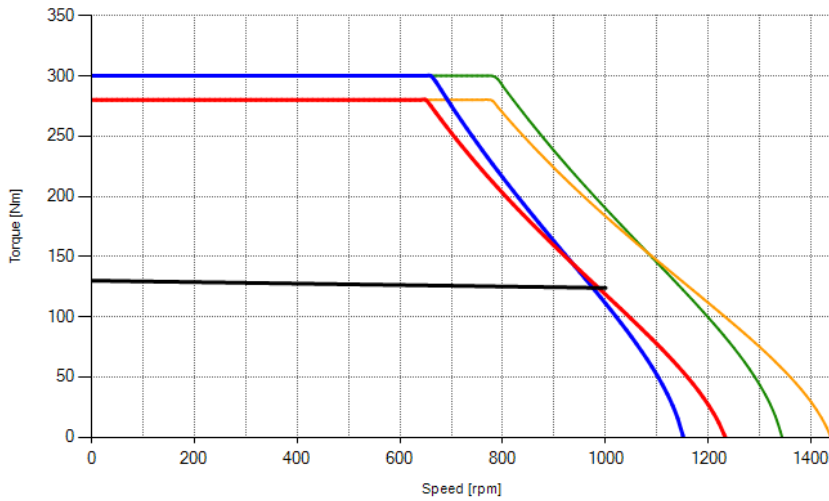

BRV86104 (1000 rpm)
 — Peak Torque 20°C, Vn=360V, I=Imax
 — Peak Torque dT 105°C, Vn=360V, I=Imax
 — Peak Torque 20°C, Vn=420V, I=Imax
 — Peak Torque dT 105°C, Vn=420V, I=Imax
 — Nominal Torque, Duty S1, dT 105°C

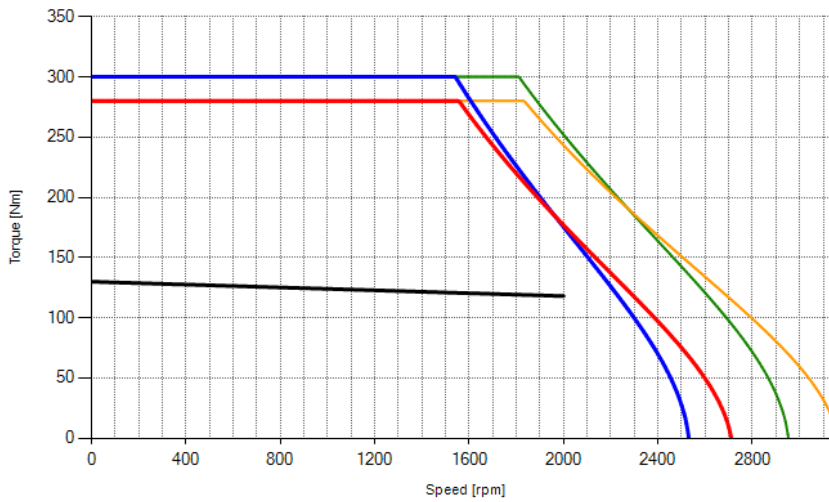

BRV86204 (2000 rpm)
 — Peak Torque 20°C, Vn=360V, I=Imax
 — Peak Torque dT 105°C, Vn=360V, I=Imax
 — Peak Torque 20°C, Vn=420V, I=Imax
 — Peak Torque dT 105°C, Vn=420V, I=Imax
 — Nominal Torque, Duty S1, dT 105°C

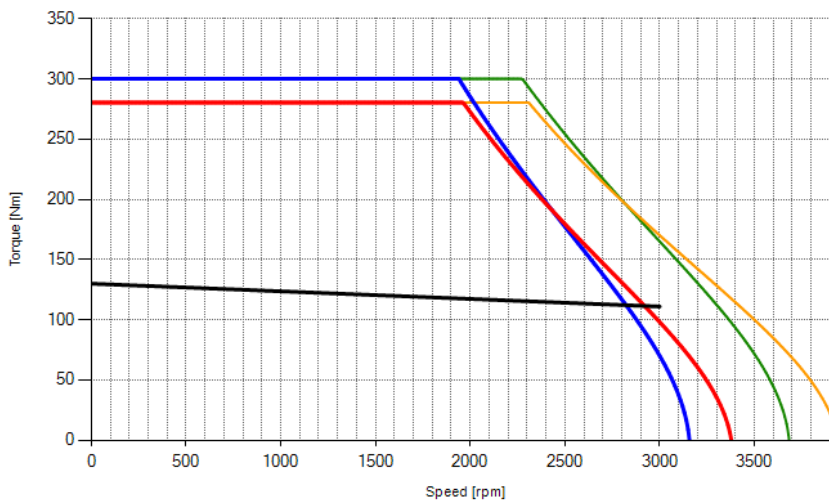

BRV86304 (3000 rpm)
 — Peak Torque 20°C, Vn=360V, I=Imax
 — Peak Torque dT 105°C, Vn=360V, I=Imax
 — Peak Torque 20°C, Vn=420V, I=Imax
 — Peak Torque dT 105°C, Vn=420V, I=Imax
 — Nominal Torque, Duty S1, dT 105°C

5.6.6.4 Curves BRV88 – 400 V

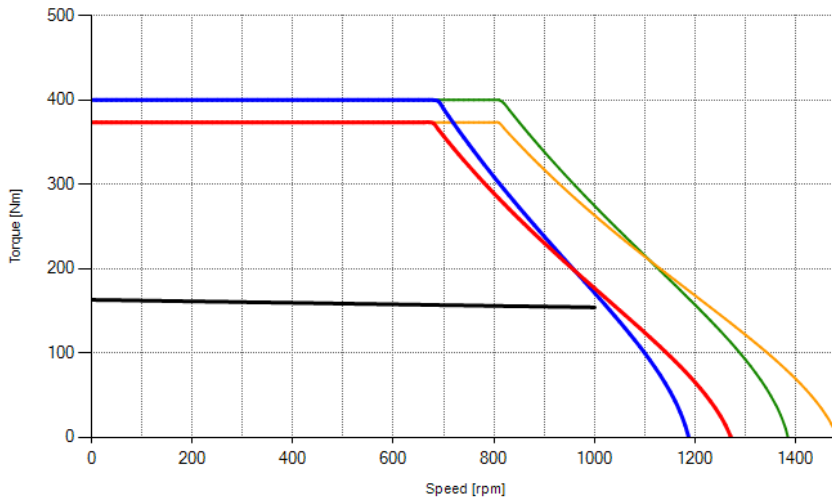

BRV88104 (1000 rpm)

- Peak Torque 20°C, Vn=360V, I=Imax
- Peak Torque dT 105°C, Vn=360V, I=Imax
- Peak Torque 20°C, Vn=420V, I=Imax
- Peak Torque dT 105°C, Vn=420V, I=Imax
- Nominal Torque, Duty S1, dT 105°C

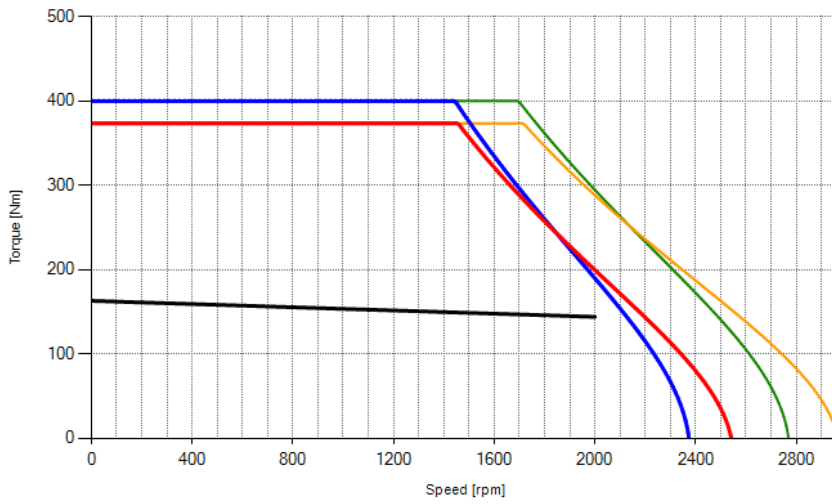

BRV88204 (2000 rpm)

- Peak Torque 20°C, Vn=360V, I=Imax
- Peak Torque dT 105°C, Vn=360V, I=Imax
- Peak Torque 20°C, Vn=420V, I=Imax
- Peak Torque dT 105°C, Vn=420V, I=Imax
- Nominal Torque, Duty S1, dT 105°C

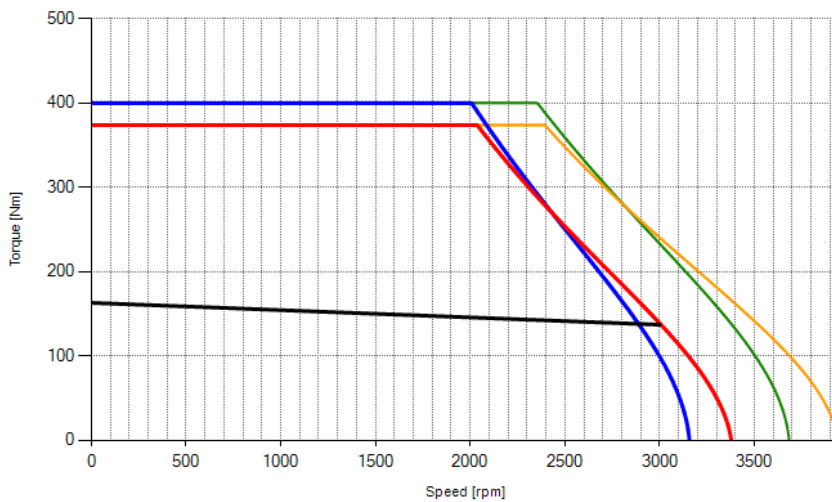

BRV88304 (3000 rpm)

- Peak Torque 20°C, Vn=360V, I=Imax
- Peak Torque dT 105°C, Vn=360V, I=Imax
- Peak Torque 20°C, Vn=420V, I=Imax
- Peak Torque dT 105°C, Vn=420V, I=Imax
- Nominal Torque, Duty S1, dT 105°C

5.6.7 Curves motor series BR09

5.6.7.1 Curves BR092 – 400 V

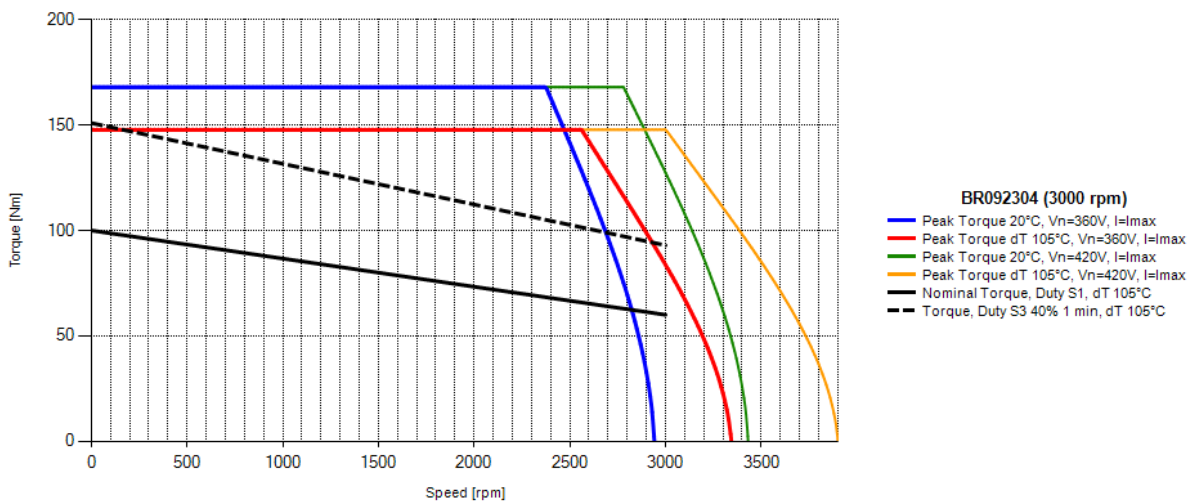
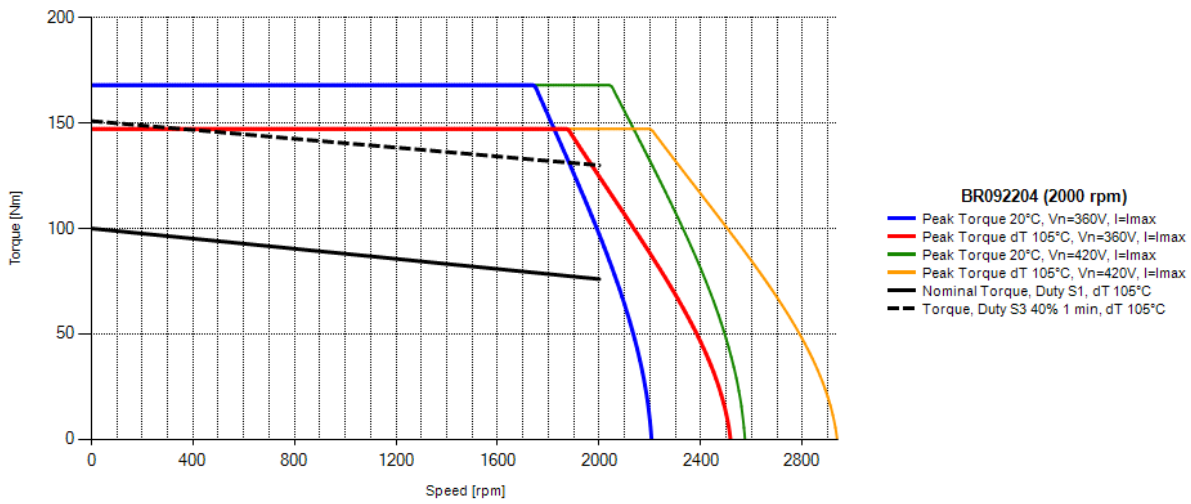
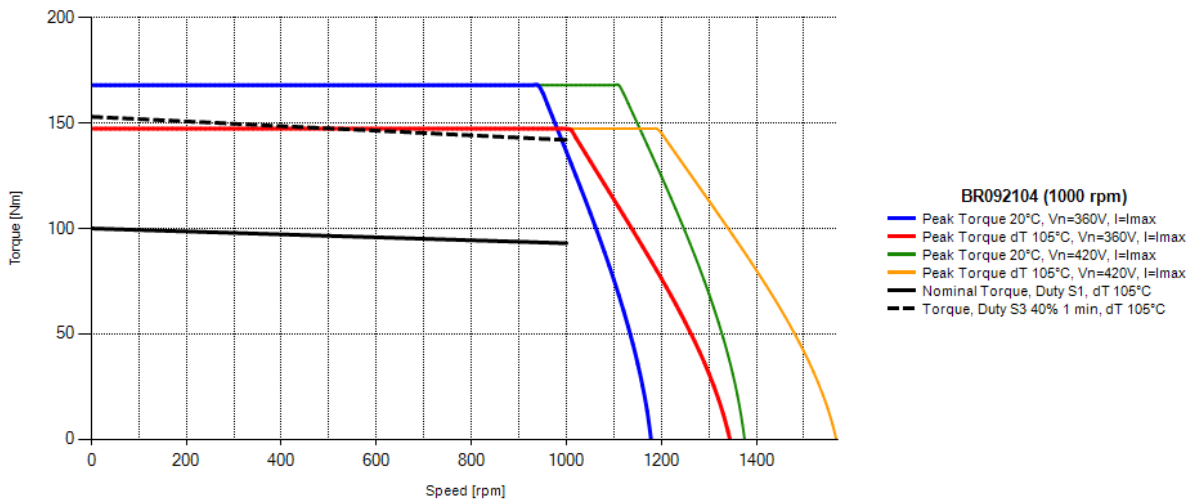

5.6.7.2 Curves BR094 – 400 V

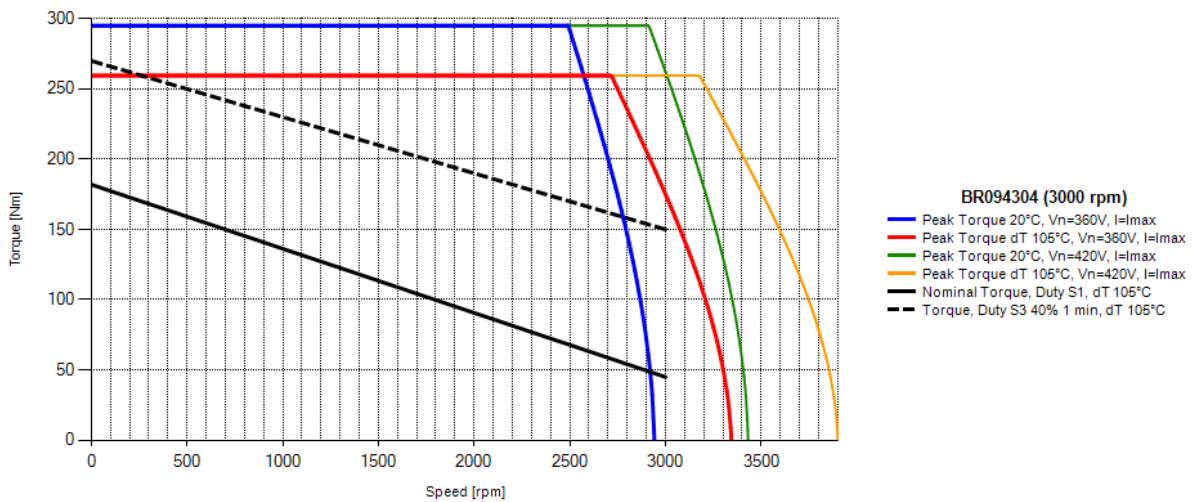
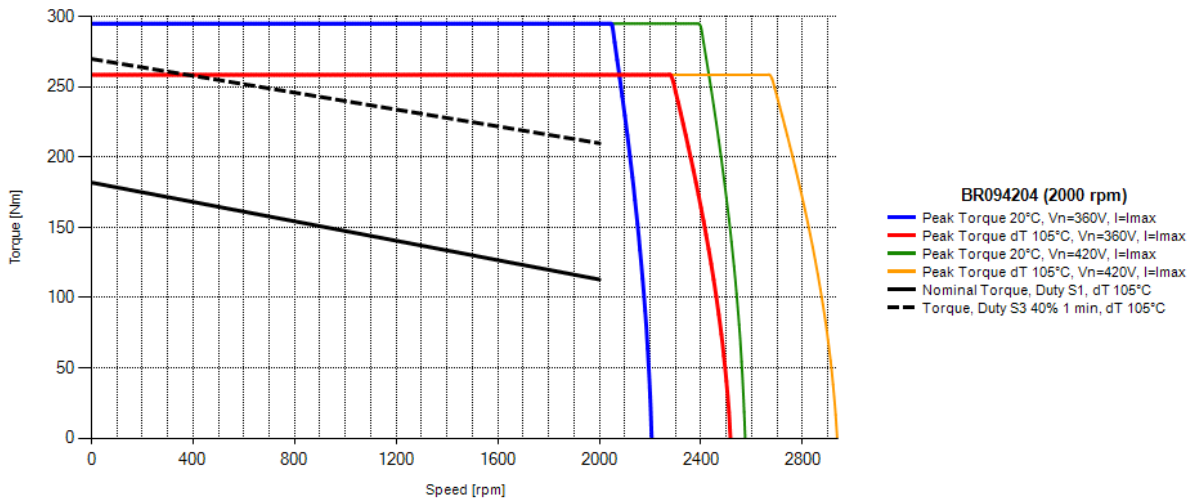
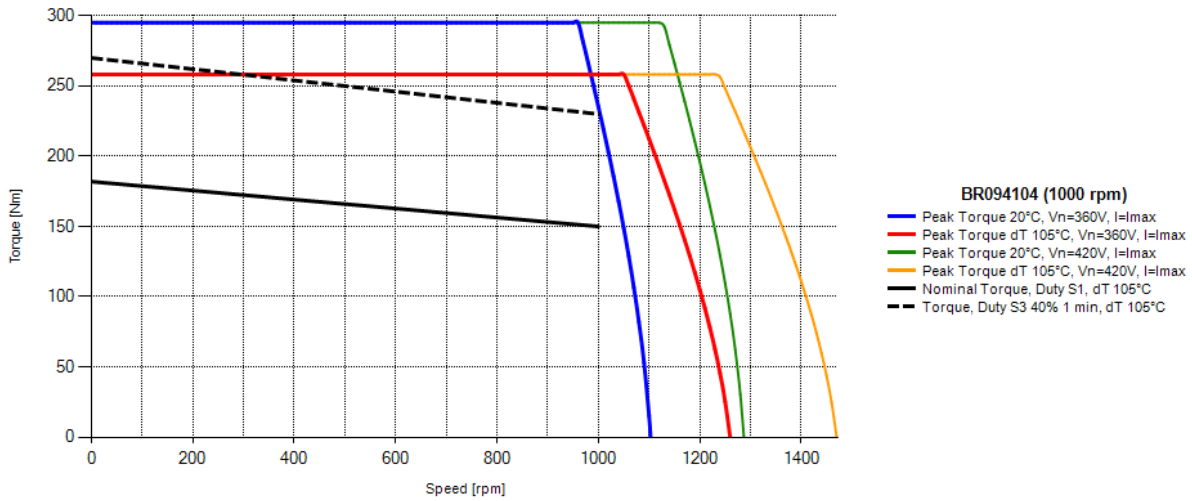

5.6.7.3 Curves BR096 – 400 V

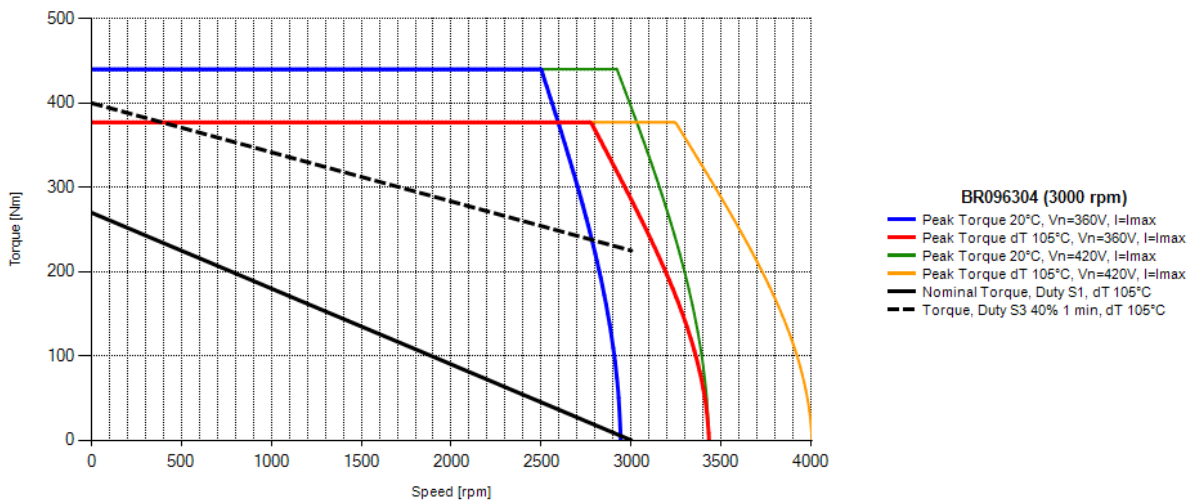
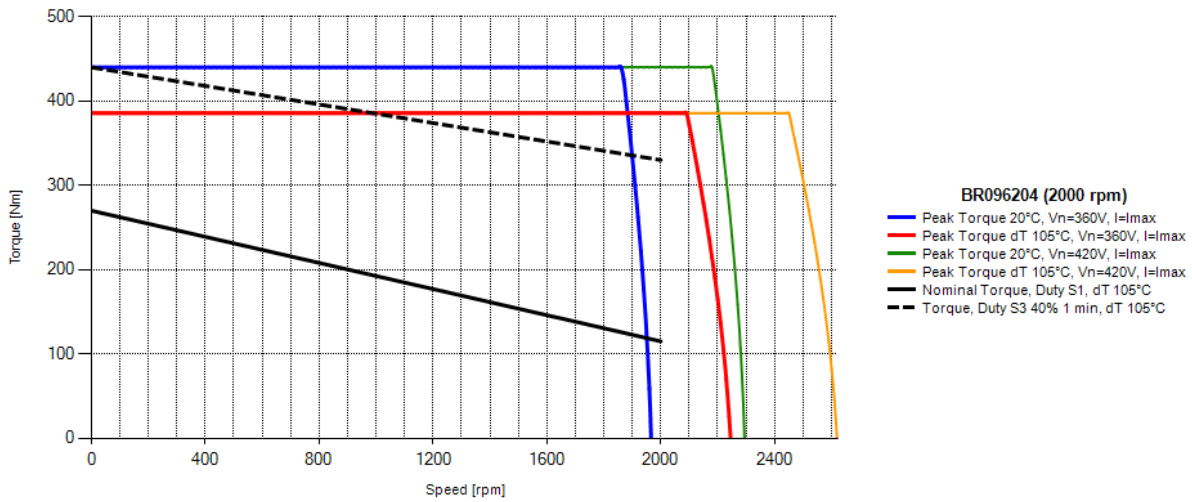
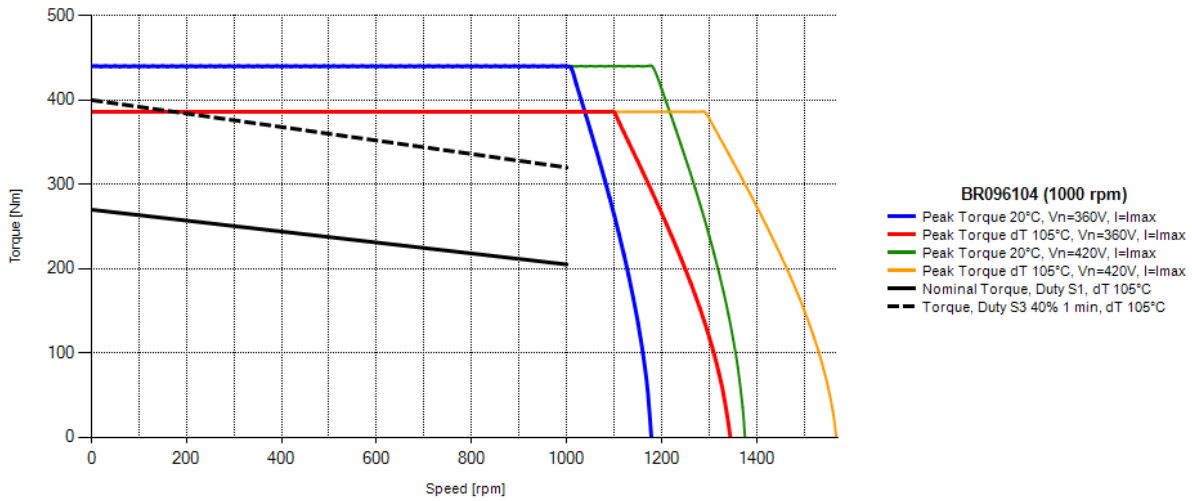

5.6.7.4 Curves BR098 – 400 V

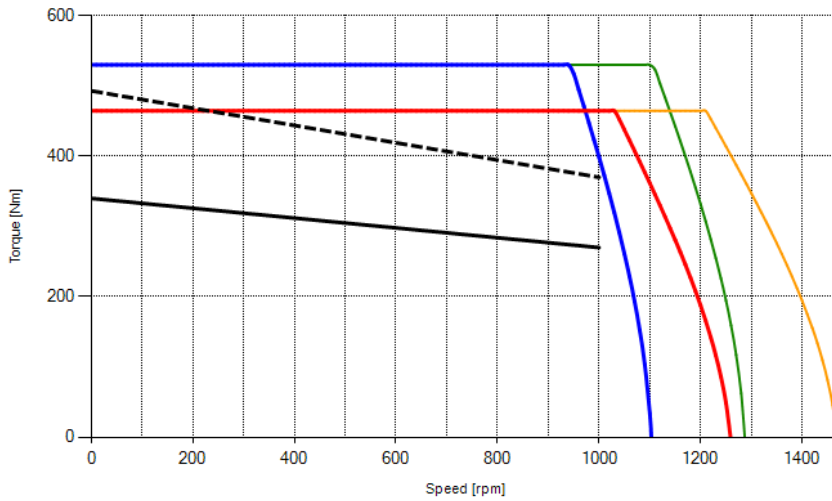

BR098104 (1000 rpm)

- Peak Torque 20°C, Vn=360V, I=Imax
- Peak Torque dT 105°C, Vn=360V, I=Imax
- Peak Torque 20°C, Vn=420V, I=Imax
- Peak Torque dT 105°C, Vn=420V, I=Imax
- Nominal Torque, Duty S1, dT 105°C
- - Torque, Duty S3 40% 1 min, dT 105°C

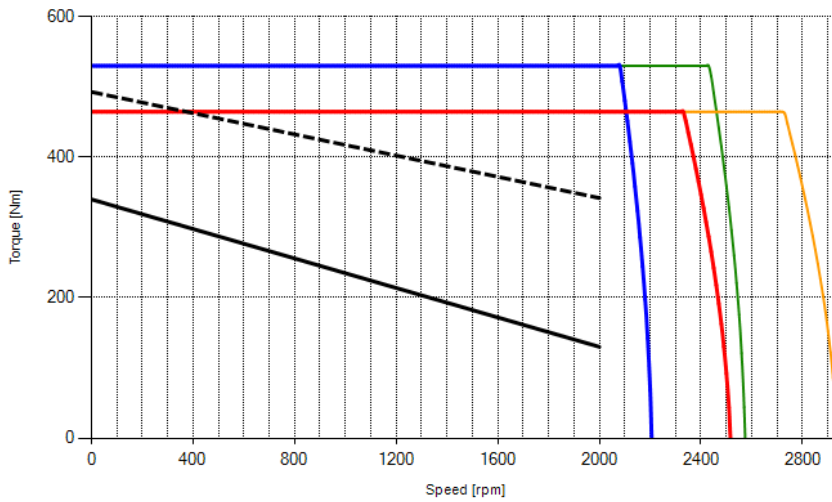

BR098204 (2000 rpm)

- Peak Torque 20°C, Vn=360V, I=Imax
- Peak Torque dT 105°C, Vn=360V, I=Imax
- Peak Torque 20°C, Vn=420V, I=Imax
- Peak Torque dT 105°C, Vn=420V, I=Imax
- Nominal Torque, Duty S1, dT 105°C
- - Torque, Duty S3 40% 1 min, dT 105°C

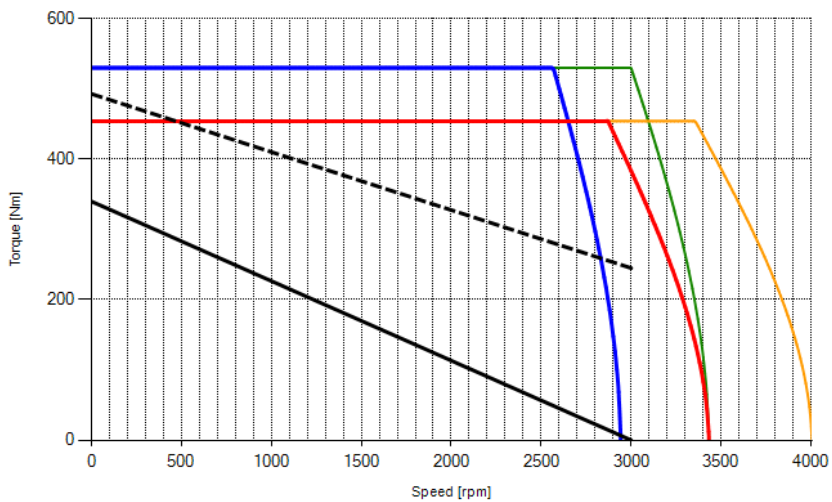

BR098304 (3000 rpm)

- Peak Torque 20°C, Vn=360V, I=Imax
- Peak Torque dT 105°C, Vn=360V, I=Imax
- Peak Torque 20°C, Vn=420V, I=Imax
- Peak Torque dT 105°C, Vn=420V, I=Imax
- Nominal Torque, Duty S1, dT 105°C
- - Torque, Duty S3 40% 1 min, dT 105°C

5.6.8 Curves motor series BRV9

5.6.8.1 Curves BRV92 – 400 V

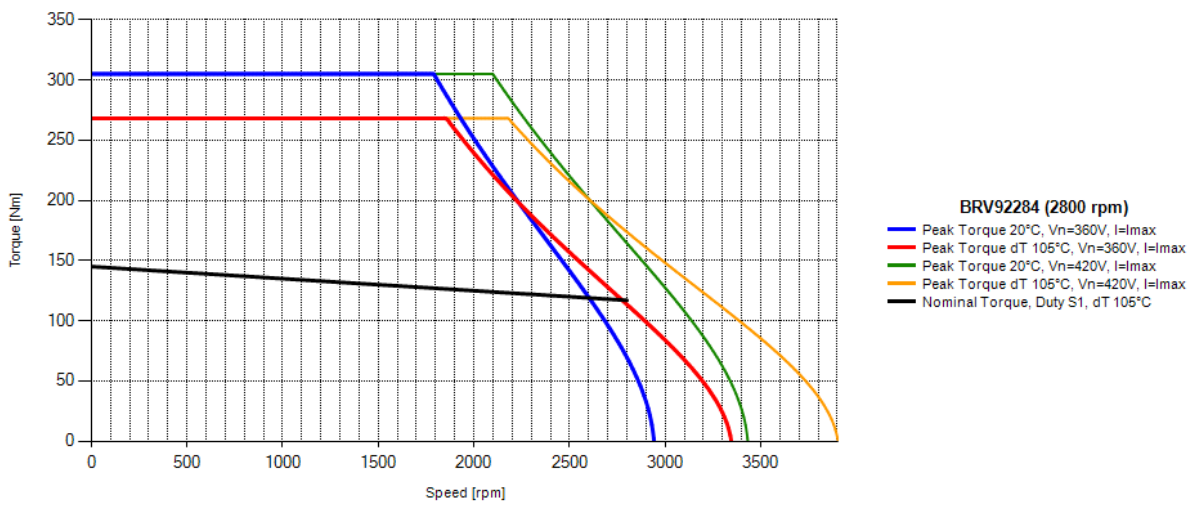
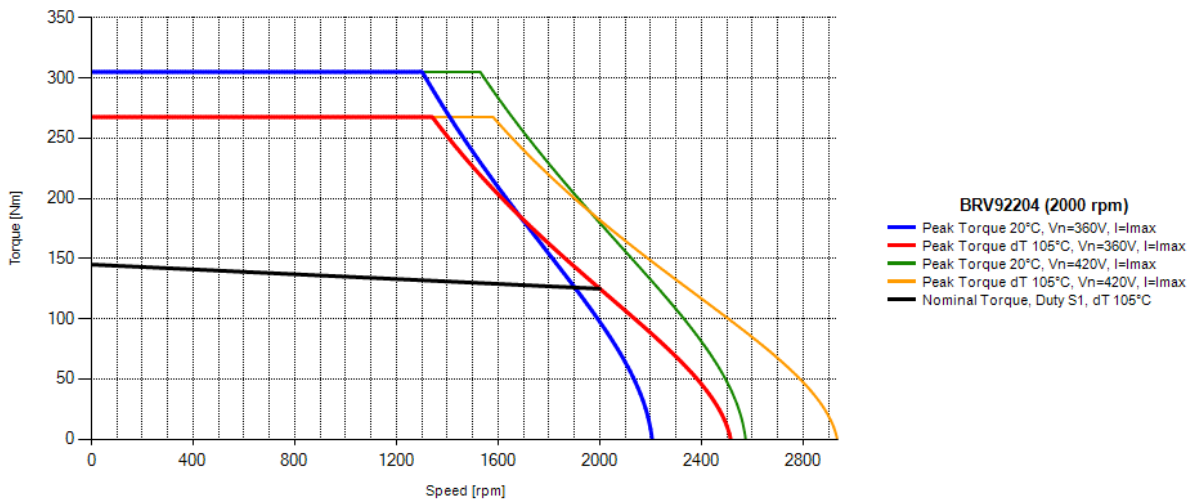
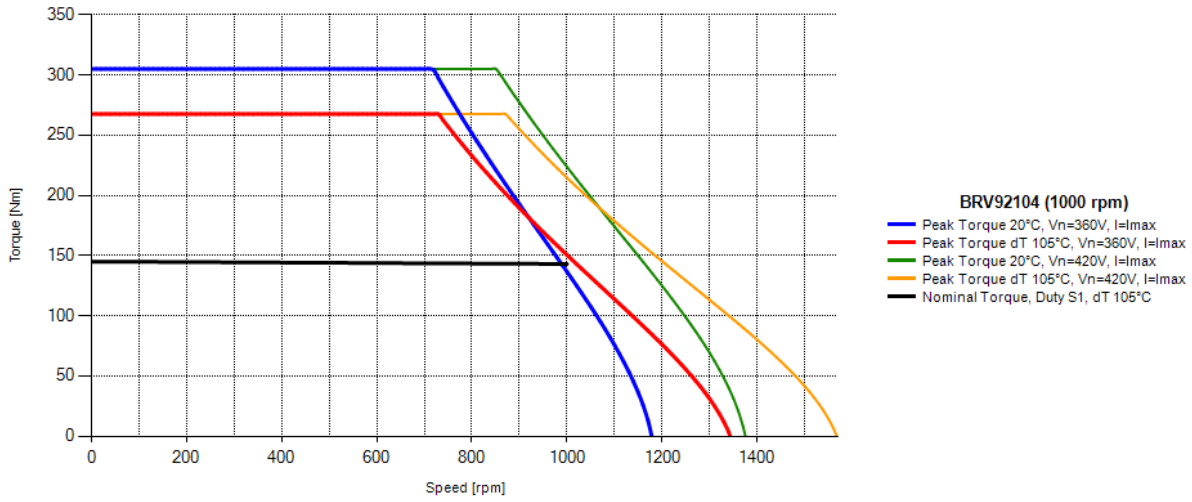

5.6.8.2 Curves BRV94 – 400 V

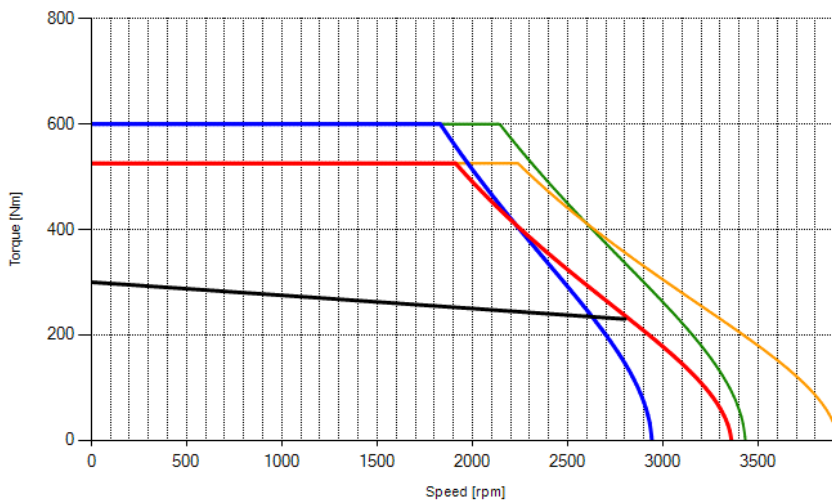
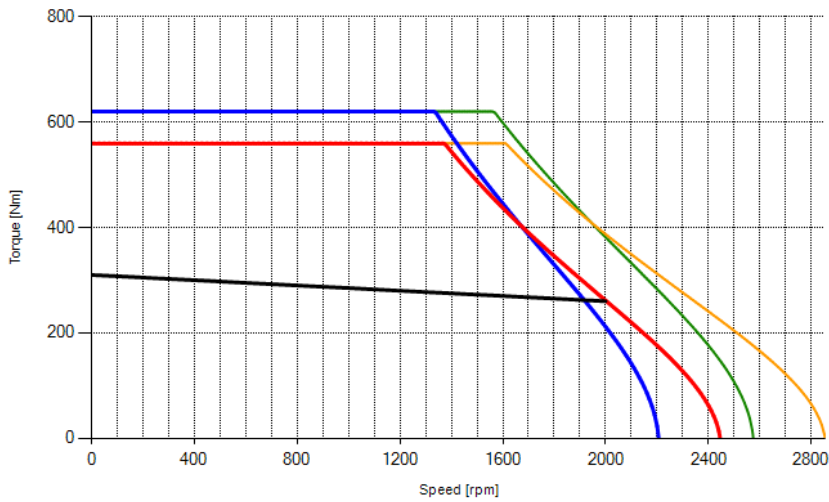
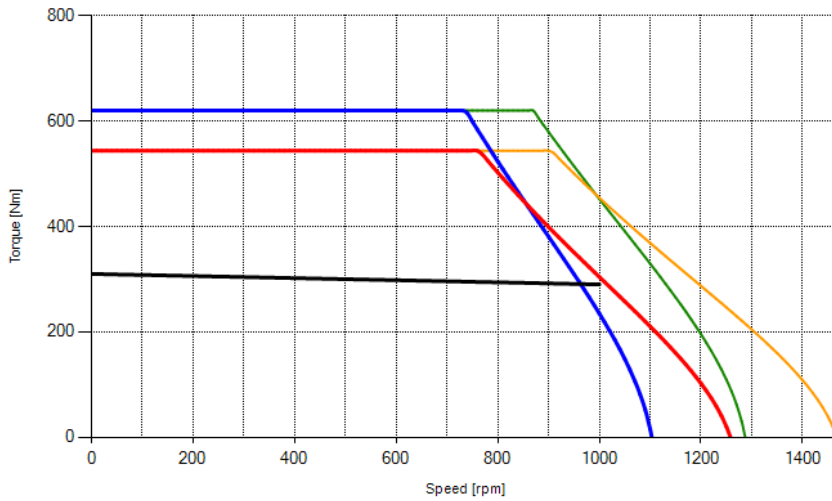

5.6.8.3 Curves BRV96 – 400 V

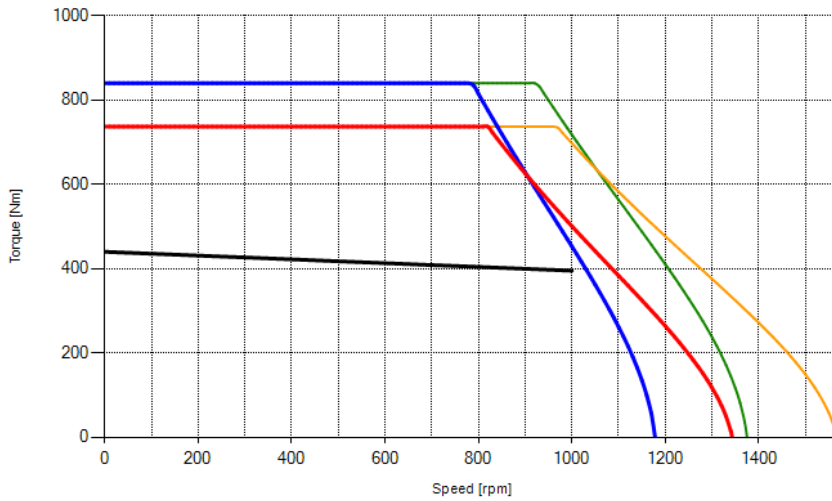

BRV96104 (1000 rpm)
 — Peak Torque 20°C, Vn=360V, I=Imax
 — Peak Torque dT 105°C, Vn=360V, I=Imax
 — Peak Torque 20°C, Vn=420V, I=Imax
 — Peak Torque dT 105°C, Vn=420V, I=Imax
 — Nominal Torque, Duty S1, dT 105°C

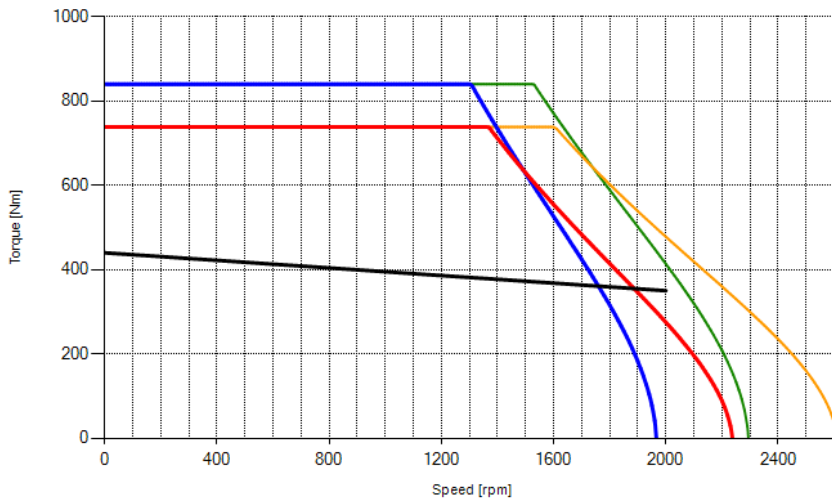

BRV96204 (2000 rpm)
 — Peak Torque 20°C, Vn=360V, I=Imax
 — Peak Torque dT 105°C, Vn=360V, I=Imax
 — Peak Torque 20°C, Vn=420V, I=Imax
 — Peak Torque dT 105°C, Vn=420V, I=Imax
 — Nominal Torque, Duty S1, dT 105°C

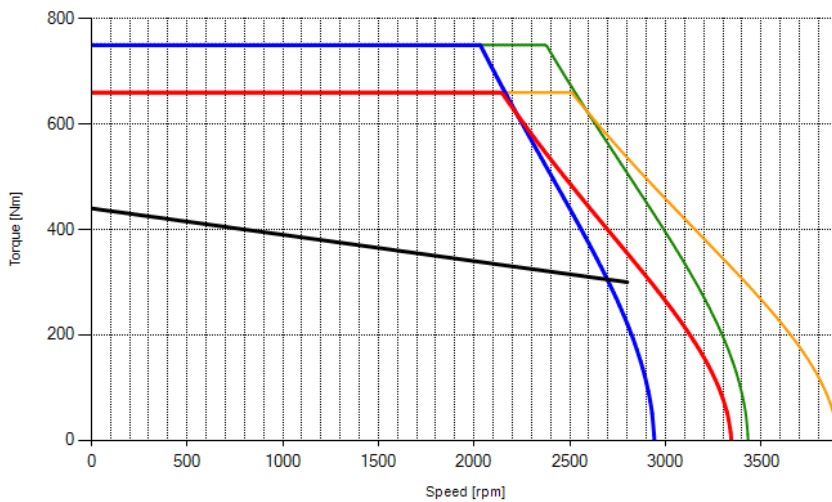

BRV96284 (2800 rpm)
 — Peak Torque 20°C, Vn=360V, I=Imax
 — Peak Torque dT 105°C, Vn=360V, I=Imax
 — Peak Torque 20°C, Vn=420V, I=Imax
 — Peak Torque dT 105°C, Vn=420V, I=Imax
 — Nominal Torque, Duty S1, dT 105°C

5.6.8.4 Curves BRV98 – 400 V

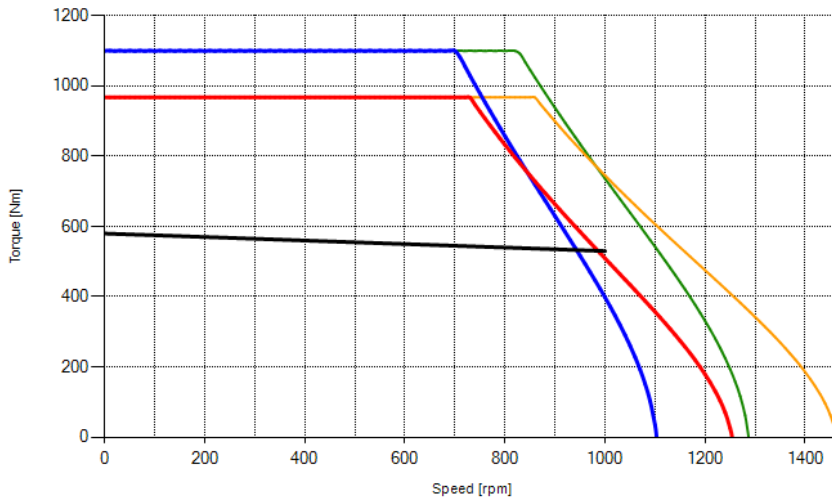

BRV98104 (1000 rpm)
 — Peak Torque 20°C, Vn=360V, I=Imax
 — Peak Torque dT 105°C, Vn=360V, I=Imax
 — Peak Torque 20°C, Vn=420V, I=Imax
 — Peak Torque dT 105°C, Vn=420V, I=Imax
 — Nominal Torque, Duty S1, dT 105°C

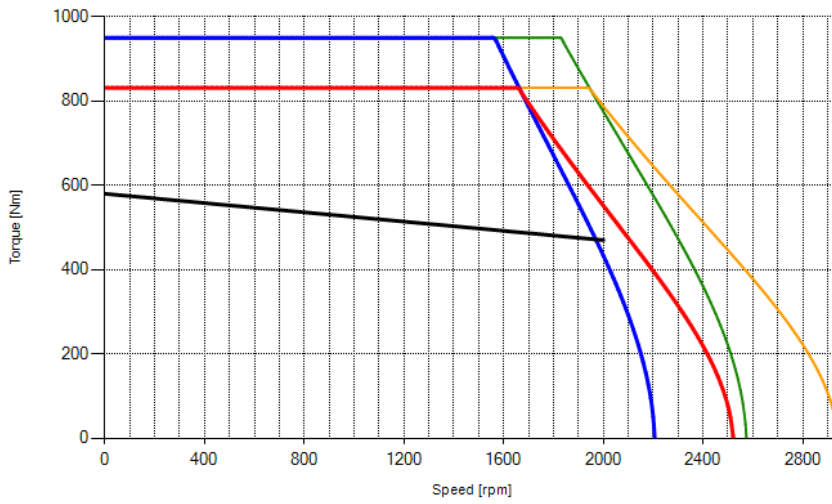

BRV98204 (2000 rpm)
 — Peak Torque 20°C, Vn=360V, I=Imax
 — Peak Torque dT 105°C, Vn=360V, I=Imax
 — Peak Torque 20°C, Vn=420V, I=Imax
 — Peak Torque dT 105°C, Vn=420V, I=Imax
 — Nominal Torque, Duty S1, dT 105°C

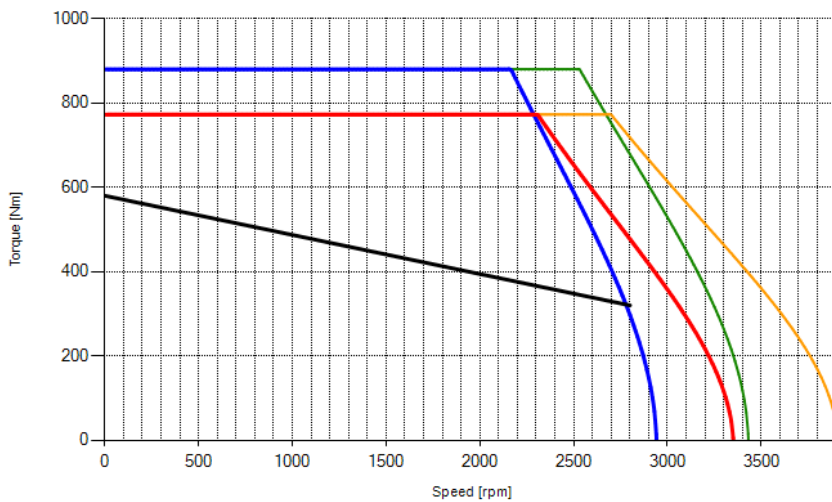

BRV98284 (2800 rpm)
 — Peak Torque 20°C, Vn=360V, I=Imax
 — Peak Torque dT 105°C, Vn=360V, I=Imax
 — Peak Torque 20°C, Vn=420V, I=Imax
 — Peak Torque dT 105°C, Vn=420V, I=Imax
 — Nominal Torque, Duty S1, dT 105°C

6. Parts and components

6.1 Cooling fan (optional)

Servo-ventilated motors are equipped with a single-phase electrical cooling fan, supplied with 230Vac 50/60Hz. opposed to

WARNING!

The minimum distance between the machine's structure and the hot air inlet/outlet must be respected.
Avoid foreign air turbulences near the motor inlet/outlet.
Make sure that nearby objects or direct sunlight does not radiate additional heat to the motor.



WARNING!

For installations in difficult environmental conditions, due to the presence of a lot of dust, water, strong humidity, sprays, steam, etc. it is necessary a periodic maintenance of the fan and motor, in order to remove the dirt deposits from the blades of the impeller/propeller and from the ventilation channels.



Air delivery/aspiration must always be through the stator in longitudinal way and exit from the opposite side.

The intake of pre-heated air or recirculation in the fan are not allowed.

A suitable lateral distance must be ensured between the motor and the other components, at least equal to the motor shaft height, on each side that do not fasten the motor to the machine.

Air temperature must always be lower than 40°C.

Electric fan circuit must always be powered on before starting the motor and must never be stopped during the operation of the motor.

Motors have fans positioned opposite to the coupling side that provides axial ventilation.

Air is aspirated from the back of the motor and moved to flange side.

Ventilation	BRV7		BRV8		BRV9	
Certification	CE/UL/CSA		CE/UL/CSA		CE/UL/CSA	
Number of phases	1~		1~		1~	
Nominal voltage (Vac)	230		230		230	
Frequency (Hz)	50	60	50	60	50	60
Speed (min ⁻¹)	2800	3300	2600	2950	2500	2600
Power (W)	24	31	38	44	155	225
Current draw (A)	0.11	0.14	0.18	0,22	0.68	0.95
Ambient temperature (°C)	-25 ÷ 45	-25 ÷ 60	-25 ÷ 60		-25 ÷ 70	-25 ÷ 65
Degree of protection	IP 44		IP 44		IP 44	
Air flow (m ³ /h)	290	340	465	535	1195	1300
Pressure (Pa)	175	245	240	325	560	720
Air flow minimal clearance (mm)	104		83		127	
Transport/Storage temperature (°C)	-40 ÷ 80		-40 ÷ 80		-40 ÷ 80	
Capacitor (µF)	1		1.5		3.5	

6.1.1 Fan connection diagrams

Standard fan without capacitor

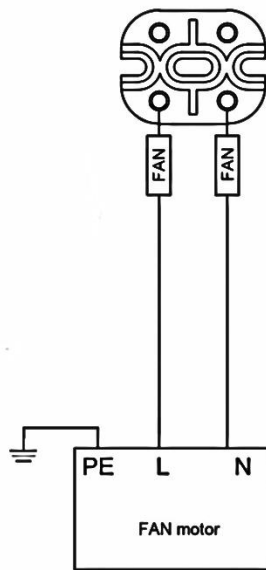

Standard fan with capacitor

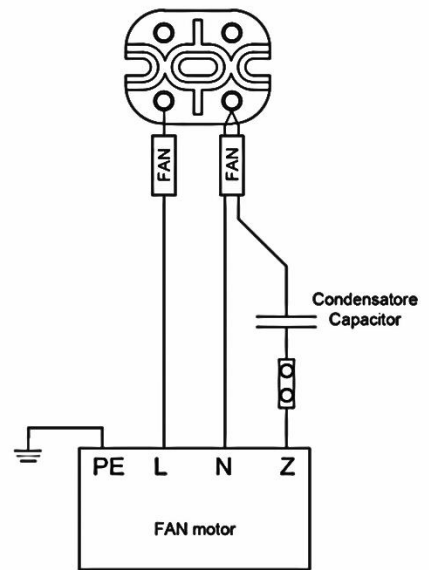

Optional:

Series BRV8 and BRV9 motors can have a fan that starts when windings temperature reaches 70 °C. If you want this option inform us when ordering.

Optional fan without capacitor

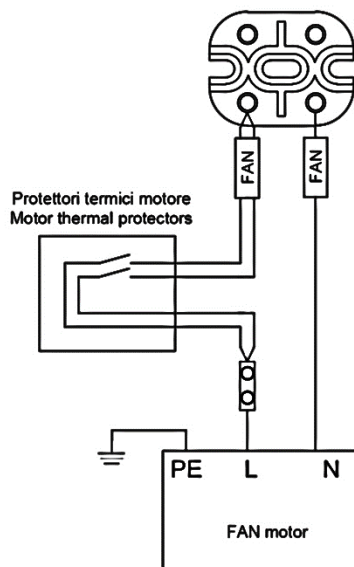

Optional fan with capacitor

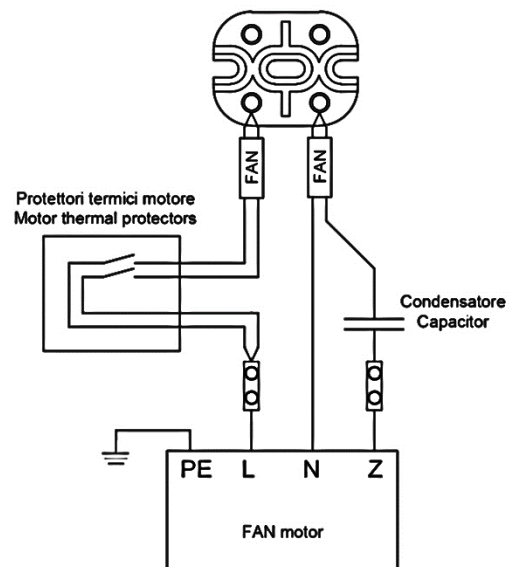

6.2 Holding brake (optional)

6.2.1 Brakes: general safety notes

When motors are equipped with a brake, proper functioning must be checked before using the motor for the first time.

The fail-safe holding brake operates according to the closed-circuit principle. It is released when a voltage of 24Vdc $\pm 5\%$ is applied. The voltage must remain within tolerance limits, otherwise operating reliability may be at risk.

WARNING!

The brake is intended to be used with the motor not moving.
It cannot be used for dynamic brakings, except on emergency.
Emergency brakings can reduce lifetime of the brake.



In normal conditions, maintenance is not required.

The brake is connected to the motor via terminal box or power connector.

Respect the correct polarities, otherwise the brake will not release.

The braking torque specified in the manual refers to dry operating brakes, without any grease on the friction surfaces.

Braking torque will be reached after a run-in time. Part of the run-in is carried out by us during our tests, and part by the user during the motor's first operations.

WARNING!

When the brake supply is disconnected, it causes an auto-induced high-level overvoltage that can create electrical noise on the signal. A protection must be provided.



Brake is incorporated in the motor coupling side and activates when supply is disconnected.

Due to dissipated power, if the brake is always powered with 24 Vdc, it is necessary a S1 service derating of stall torque of the motor.

Brake must be activated and deactivated when the rotor is not moving.

WARNING!

Spring brakes (6.2.1) are considered "emergency brakes".
Permanent magnet brakes (6.2.2) are NOT to be considered "emergency brakes".



Notes:

Brake temperature is usually less than the temperature measured by thermal sensors, so holding torque should be higher than the declared value.

For certain motor types, nominal torque of the motor may be higher than the brake's holding torque.

6.2.2 Safety and maintenance notes for permanent magnet brakes

WARNING!

After a braking, the brake surface can reach high temperatures.
Be careful when touching it.



Protect the brake against the ingress of foreign particles into the air gap. These particles may impede the movement of the armature.

WARNING!

Exceeding technical specifications may result in thermal overload at the braking surface or magnet. This may lead to failure of the brake.



If the brake is only used as a holding brake without dynamic load, the braking torque may drop. A new run in (refreshment) must be done within the scope of maintenance.

The brake is mainly maintenance-free.

As a result of wear occurring during operation, the air gap increases.

The function of the brake can only be ensured when the air gap is checked at regular intervals.

Readjustment of the air gap is not possible! If necessary, check the air gap before mounting.

Rated braking torque is only reached after running-in of the brake.

Maintenance running-in of the brake

Maintenance interval	4 weeks								
Slip time (s)	0.5								
Idle time (s)	0.5								
Speed (rpm)	250	200	200	100	100	75	50	25	15
Circuits	5	5	5	5	5	5	3	3	3

6.2.3 Permanent magnet brakes

Motor size	Unit	BR_3	BR_5	BR_7	BR_8	-	-
Order key code		AA	BA	CA	DA		
Holding torque (T=100 °C)	Nm	4	15	32	130		
Holding torque (T=20 °C)	Nm	4.5	18	36	145		
Nominal voltage $\pm 5\%$	Vdc	24	24	24	24		
Holding voltage	Vdc	12	12	12	12		
Motor torque reduction ⁽¹⁾	%	10	10	10	10		
Maximum current draw	A	0.5	1	1.1	2.1		
Disc inertia	kg cm ²	0.18	1.66	5.56	53		
Power	W	12	24	26	50		
Total weight	kg	0.35	0.85	1.6	5.4		
Engaging time (t₁) ⁽²⁾	ms	7	10	22	65		
Release time (t₂) ⁽³⁾	ms	35	50	90	190		
Maximum rotation admissible speed	rpm	10000	6000	6000	6000		
Additional motor length	mm	-	40	50	120		
Maximum energy for single braking/hour	kJ	8	15	30	65		
Emergency brake		No	No	No	No		

⁽¹⁾ It is not necessary to apply motor torque reduction percentage if holding voltage is supplied to the brake

⁽²⁾ **t₁** = Time from 0% to 90% of holding torque when supply is disconnected

⁽³⁾ **t₂** = Time from 100% to 10% of holding torque when supply is connected

6.2.4 Spring brake (emergency brake)

Motor size	Unit	-	BR_5	BR_7	BR_8	BR_92 BR_94	BR_96 BR_98
Order key code			10	20	30	40	50
Holding torque	Nm		15	31	160	225	450
Nominal voltage $\pm 5\%$	Vdc		24	24	24	24	24
Holding voltage	Vdc		12	12	12	12	12
Motor torque reduction ⁽¹⁾	%		10	10	10	10	10
Maximum current draw	A		0.7	1.4	2.3	3.1	3.1
Disc inertia	kg cm ²		0.34	2.05	44.8	64.8	129.6
Power	W		16	34	55	75	75
Total weight	kg		1.2	2.7	16.1	24.8	29.8
Engaging time (t₁) ⁽²⁾	ms		20	10	15	15	120
Release time (t₂) ⁽³⁾	ms		40	70	80	100	115
Maximum rotation admissible speed	rpm		6000	6000	6000	4500	4500
Additional motor length	mm		40	50	120	135	135
Maximum energy for single braking/hour	kJ		5	6	20	30	60
Maximum number of brakings admissible with maximum energy ⁽⁴⁾			193	150	183	228	228
Emergency brake			Yes	Yes	Yes	Yes	Yes

⁽¹⁾ It is not necessary to apply motor torque reduction percentage if holding voltage is supplied to the brake

⁽²⁾ **t₁** = Time from 0% to 90% of holding torque when supply is disconnected

⁽³⁾ **t₂** = Time from 100% to 10% of holding torque when supply is connected

⁽⁴⁾ Based on the single braking/hour. After reaching maximum number, restore air gap.

6.3 Position sensor

Usually, an encoder or a hollow shaft resolver is used.

For encoders, the transducer body is fastened to the rear cover of the motor and is made free to oscillate by a reaction arm that has the task of absorbing any axial/radial misalignments.

A male connector is used for the electrical connection.

A flying connector with solder contacts is optional.

- Always check that the electrical values of the transducer are compatible with those of the inverter powering the motor, and that the supply voltage and connections are correct.
- Do not power the output channels of the transducer and never operate the motor if the transducer has the output cables short-circuited between them or towards ground.
- Do not perform high voltage test on the transducer terminals.
- Always use shielded cable to connect to the Drive.
- When soldering the optional flying connector, do not overheat the contacts.
- Avoid short-circuits between the contacts of the connector.
- Avoid impacts and shocks on the transducer.

WARNING!

Failing to comply with one of the above-mentioned warnings can cause the transducer to break immediately.



6.3.1 Transducer operating temperature

Each transducer has its own operating temperature; motor temperature should be constantly monitored in order to avoid surpassing temperature limits of the transducer, preserving its correct functioning.

Resolvers are, thermically and mechanically, sturdy transducers and they can work at the same temperature of the motor windings, having the same insulation class.

Optical encoders have a lower thermal limit. Because of this, if motors have encoder feedback, it is recommended to monitor internal motor temperature, using optional temperature sensors (Pt1000 or Pt100) in order to limit motor temperature to the operating temperature limit of the encoder installed.

Therefore, limiting maximum motor temperature, stall torque and nominal torque will also be lower than the values indicated in data charts (which were obtained using a resolver as feedback).

6.3.2 Resolver (standard)

Motor	BR 3	BR 5-7-8-9
Type	Resolver	Resolver
Number of poles	2	2
Input voltage (Vrms)	7	7
Input frequency (kHz)	5	10
Transformation ratio	0.5 ± 10%	0.5 ± 5%
Input current - MAX (mA)	58	50
Operating temperature (°C)	-55 ÷ 155	

6.3.3 Encoder SinCos (optional)

Motor	BR 5-7-8-9
Type	Sin/Cos 1 Vpp
Model	ERN 1385
Nominal voltage (Vdc)	5 ± 0.25
Line count	2048
Total steps per revolution	-
Current consumption with no load (mA)	≤130
Operative temperature (°C)	-40 ÷ 120

6.3.4 Encoder Hiperface (optional)

Motor	BR 5-7-8-9			
Type	Absolute			
Sub-type	Singleturn		Multiturn (4096)	
Model	SRS50	SRS50S	SRM50	SRM50S
Protocol	Hiperface			
Nominal voltage (Vdc)	7÷12			
Line count	1024			
Total steps per revolution	15 bit		27 bit	
Current consumption with no load (mA)	80			
Operative temperature (°C)	-30 ÷ 115			
Safety Integrity Level (SIL)	No	Yes	No	Yes

6.3.5 Encoder EnDat (optional)

Motor	BR 5-7-8-9			
Type	Absolute			
Sub-type	Singleturn		Multiturn (4096)	
Model	ECN 1313	ECN 1325	EQN 1325	EQN 1337
Interface	EnDat 01	EnDat 22	EnDat 01	EnDat 22
Nominal voltage (Vdc)	3.6 ÷ 14			
Line count	2048	2048	512	2048
Total steps per revolution	13 bit	25 bit	25 bit	37 bit
Current consumption with no load (mA)	85		105	
Operative temperature (°C)	-40 ÷ 115			
Safety Integrity Level (SIL)	Unavailable	Available	Unavailable	Available

6.4 Thermal protection

As standard thermal protection the motor is equipped with a PTC thermistor incorporated in the windings. Other thermal protections can be mounted on request: Bimetal switch and thermo-resistances Pt100 e Pt1000. Usually, the connection terminal is placed inside the terminal box of the motor or inside the connector.

WARNING!

Not connecting the thermal protection immediately makes the liability invalid.



WARNING!

Do not perform high voltage tests on the terminals of the thermal protectors.



6.4.1 Thermistor PTC (standard)

These sensors are Positive Temperature Coefficient, made of semiconductor material.

Configuration: Single for series 3, 5, 7 and triplex for series 8, 9

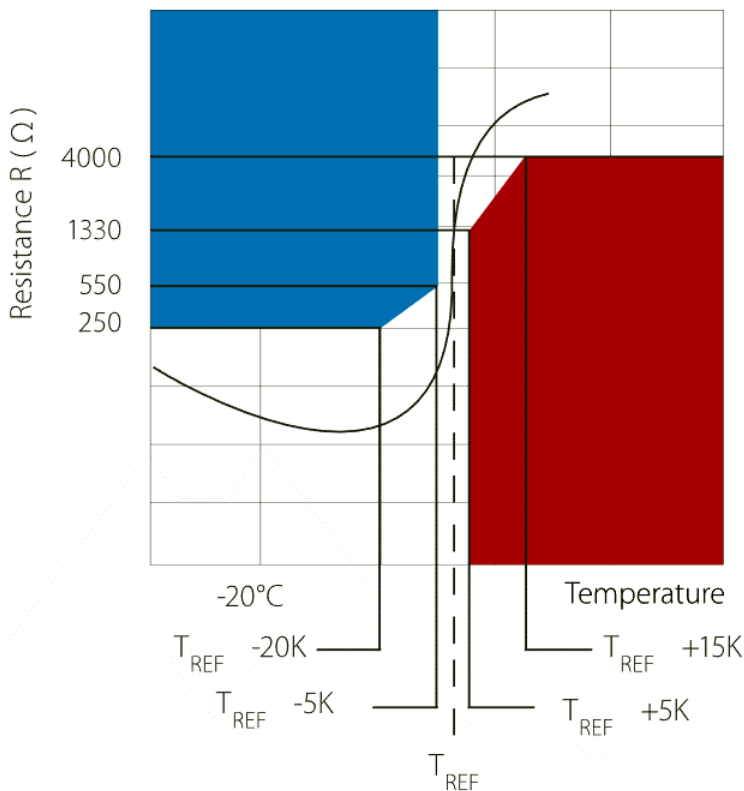

Note:

Resistance values refer to single configuration.
When using triplex configuration, given resistance in the diagram must be multiplied by 3.

6.4.2 Bimetal switch (optional)

The normally closed contact opens when the probe reaches the switching value. Sometimes the thermal inertia of the bimetal switch fails to protect the motor from sudden and high overloads.

Contact:	Normally closed
Opening temperature:	130 ± 5 °C
Maximum voltage:	250 Vac
Maximum current:	5 Aac
Configuration:	Single for series 3, 5, 7 and triplex for series 8, 9

6.4.3 Bimetal switch (optional for ventilation starting)

Contact:	Normally open
Opening temperature:	70 ± 5 °C
Maximum voltage:	250 Vac
Maximum current:	5 Aac
Configuration:	Double in parallel for series 8, 9

6.4.4 Thermo-resistance Pt100 or Pt1000 (optional)

They are RTD-type sensors (Platinum Resistance Temperature Detectors).

Pt100

$$\Delta T = \pm(0,3 + 0,005T) \text{ } ^\circ\text{C}$$

$$R_0 = R(0 \text{ } ^\circ\text{C}) = 100 \text{ } \Omega$$

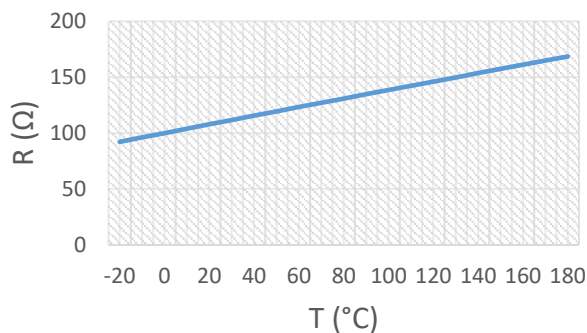

°C	Ω	°C	Ω	°C	Ω
-20	92.16	50	119.4	120	146.06
-10	96.09	60	123.24	130	149.82
0	100	70	127.07	140	153.58
10	103.9	80	130.89	150	157.31
20	107.79	90	134.7	160	161.04
30	111.67	100	138.5	170	164.76
40	115.54	110	142.29	180	168.46

Pt1000

$$\Delta T = \pm(0,3 + 0,005T) \text{ } ^\circ\text{C}$$

$$R_0 = R(0 \text{ } ^\circ\text{C}) = 1000 \text{ } \Omega$$

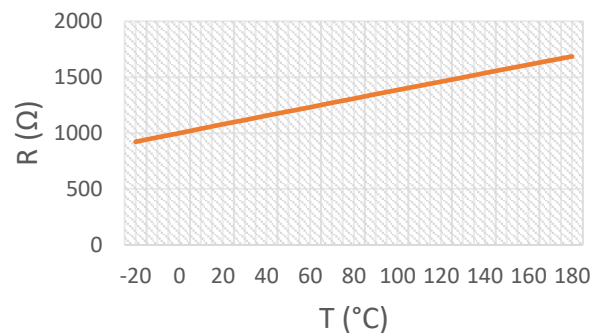

°C	Ω	°C	Ω	°C	Ω
-20	922	50	1194	120	1461
-10	961	60	1232	130	1498
0	1000	70	1271	140	1536
10	1039	80	1309	150	1573
20	1078	90	1347	160	1611
30	1117	100	1385	170	1648
40	1155	110	1423	180	1685

6.5 Bearings

Standard motors have ball bearings suitable for high-speed rotation and lubricated with special high temperature resistant greases.

Starting the motor for the first time, it is advisable to run-in the bearings. Increase the motor speed progressively from 0% to about 70% of the maximum speed in about 20 minutes.

In the first minutes of operation, a noise higher than usual can be heard due to the non-uniform distribution of grease inside the bearings. The noise should return to normal at the end of the run-in.

Any gaskets or sealing rings placed to protect the bearing can be removed only if not necessary for the purpose (particularly clean environment, additional external mechanical protection). In this way, friction and operating temperature will decrease.

6.6 Maximum radial load on 20000 hours of operation

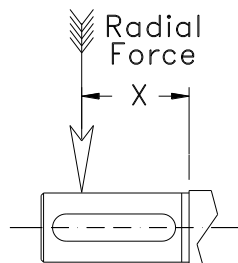

Motor	BR 3		D.E. / N.D.E. bearing type: 6002 ZZ / 6902 ZZ								Maximum radial load of shaft: 500 N	
dimens. X (mm)	Rotor speed											
	50 rpm	100 rpm	250 rpm	500 rpm	750 rpm	1000 rpm	1500 rpm	2000 rpm	2500 rpm	3000 rpm	4000 rpm	
23.00	500	500	500	490	427	388	338	307	285	268	243	
20.13	500	500	500	500	437	397	346	314	291	274	249	
17.25	500	500	500	500	447	406	354	321	298	280	254	
14.38	500	500	500	500	457	415	362	329	305	287	260	
11.50	500	500	500	500	468	425	371	336	312	294	266	
8.63	500	500	500	500	479	435	380	345	320	301	273	
5.75	500	500	500	500	491	446	389	353	328	308	280	
2.88	500	500	500	500	500	457	399	362	336	316	287	
0.00	500	500	500	500	500	469	410	372	345	324	294	
Max. radial force (N)												

Motor	BR 5		D.E. / N.D.E. bearing type: 6204 ZZ / 6203 ZZ								Maximum radial load of shaft: 1325 N	
dimens. X (mm)	Rotor speed											
	50 rpm	100 rpm	250 rpm	500 rpm	750 rpm	1000 rpm	1500 rpm	2000 rpm	2500 rpm	3000 rpm	4000 rpm	
40.00	1325	1325	1112	881	768	697	608	551	511	480	435	
35.00	1325	1325	1154	914	797	723	630	572	530	498	452	
30.00	1325	1325	1199	950	828	751	655	594	551	518	469	
25.00	1325	1325	1248	988	862	782	682	618	573	539	488	
20.00	1325	1325	1301	1030	898	815	711	645	598	562	509	
15.00	1325	1325	1325	1076	938	851	742	673	624	586	532	
10.00	1325	1325	1325	1125	982	891	776	704	653	614	556	
5.00	1325	1325	1325	1180	1029	934	814	738	685	643	583	
0.00	1325	1325	1325	1240	1082	982	856	776	719	676	613	
Max. radial force (N)												

Motor	BR 71÷76		D.E. / N.D.E. bearing type:					6206 ZZ / 6205 ZZ		Maximum radial load of shaft Ø24x50:			2300 N
dimens. X (mm)	Rotor speed												
	50 rpm	100 rpm	250 rpm	500 rpm	750 rpm	1000 rpm	1500 rpm	2000 rpm	2500 rpm	3000 rpm	4000 rpm		
50.00	2300	2300	1825	1442	1256	1139	991	898	831	780	-		
43.75	2300	2300	1887	1492	1299	1178	1025	928	860	807	-		
37.50	2300	2300	1954	1545	1345	1219	1061	961	890	836	-		
31.25	2300	2300	2026	1601	1395	1264	1100	997	923	867	-		
25.00	2300	2300	2104	1663	1448	1313	1142	1035	958	900	-		
18.75	2300	2300	2187	1729	1506	1365	1188	1076	996	935	-		
12.50	2300	2300	2278	1800	1568	1421	1237	1120	1038	974	-		
6.25	2300	2300	2300	1878	1636	1483	1290	1169	1082	1016	-		
0.00	2300	2300	2300	1963	1710	1550	1349	1222	1131	1062	-		
Max. radial force (N)													

Motore	BR 77÷78		D.E. / N.D.E. bearing type:					6206 ZZ / 6205 ZZ		Maximum radial load of shaft Ø28x60:			3300 N
Quota X (mm)	Velocità rotore												
	50 rpm	100 rpm	250 rpm	500 rpm	750 rpm	1000 rpm	1500 rpm	2000 rpm	2500 rpm	3000 rpm	4000 rpm		
60,00	2983	2362	1733	1370	1193	1081	941	852	789	741	-		
52,50	3100	2455	1801	1423	1240	1124	978	886	820	770	-		
45,00	3227	2555	1874	1481	1290	1170	1018	922	854	802	-		
37,50	3300	2664	1954	1545	1345	1219	1061	961	890	836	-		
30,00	3300	2782	2041	1613	1405	1274	1108	1004	930	873	-		
22,50	3300	2912	2136	1689	1471	1333	1160	1051	973	914	-		
15,00	3300	3054	2241	1771	1543	1398	1217	1102	1021	958	-		
7,50	3300	3211	2356	1862	1622	1470	1279	1159	1073	1008	-		
0,00	3300	3300	2484	1963	1710	1550	1349	1222	1131	1062	-		
Forza radiale massima (N)													

Motor	BR 8		D.E. / N.D.E. bearing type:					6309 ZZ / 6306 ZZ		Maximum radial load of shaft:			5750 N
dimens. X (mm)	Rotor speed												
	50 rpm	100 rpm	250 rpm	500 rpm	750 rpm	1000 rpm	1500 rpm	2000 rpm	2500 rpm	3000 rpm	4000 rpm		
82.00	5750	5750	4622	3660	3192	2896	2525	2290	2123	1996	-		
71.75	5750	5750	4809	3808	3321	3013	2627	2383	2209	2076	-		
61.50	5750	5750	5011	3968	3461	3140	2738	2483	2302	2164	-		
51.25	5750	5750	5231	4143	3613	3278	2858	2592	2403	2259	-		
41.00	5750	5750	5472	4333	3779	3429	2989	2712	2514	2363	-		
30.75	5750	5750	5735	4542	3961	3594	3133	2842	2635	2476	-		
20.50	5750	5750	5750	4772	4162	3776	3292	2986	2768	2602	-		
10.25	5750	5750	5750	5026	4383	3977	3467	3145	2916	2740	-		
0.00	5750	5750	5750	5309	4630	4201	3663	3322	3080	2895	-		
Max. radial force (N)													

Motor	BR 9		D.E. / N.D.E. bearing type:					6313 ZZ NR / 6309 ZZ		Maximum radial load of shaft:			7450 N
dimens. X (mm)	Rotor speed												
	50 rpm	100 rpm	250 rpm	500 rpm	750 rpm	1000 rpm	1500 rpm	2000 rpm	2500 rpm	3000 rpm	4000 rpm		
110.0	7450	7450	7450	6561	5721	5190	4523	4102	3802	3573	-		
96.25	7450	7450	7450	6822	5948	5397	4703	4265	3953	3715	-		
82.50	7450	7450	7450	7105	6195	5620	4898	4442	4117	3869	-		
68.75	7450	7450	7450	7412	6463	5864	5110	4634	4295	4037	-		
55.00	7450	7450	7450	7450	6756	6129	5342	4844	4490	4219	-		
41.25	7450	7450	7450	7450	7076	6419	5595	5074	4702	4419	-		
27.50	7450	7450	7450	7450	7427	6738	5873	5326	4936	4639	-		
13.75	7450	7450	7450	7450	7450	7091	6180	5605	5195	4882	-		
0.00	7450	7450	7450	7450	7450	7450	6521	5914	5481	5151	-		
Max. radial force (N)													

7. Electrical connections

7.1 Instructions on safety

WARNING!

Do not operate on the motor, the connection cables, the frequency converters, or accessories (e.g. brakes, thermal protection, fan) when supply is on.



WARNING!

System must be disconnected from the power supply and the rotor must be stopped before any work is carried out. Since motors contain permanent magnets, a voltage is generated on the motor terminals when the rotor is turning, so don't touch the motor terminals even if the cables aren't plugged in.



WARNING!

Never rotate the motor shaft if the drive is connected but powered off or out of service, because the motor or the drive could be damaged.



WARNING!

The motors must be controlled by appropriate converters. Direct connection to the three-phase AC supply is not allowed and will lead to the destruction of the motor.



WARNING!

For cable inlet, use cable glands and seals suitable for the type of protection and diameter of the cable.



WARNING!

Also refer to the chapters of thermal protection, brake and cooling fan in this manual for additional information if they are present. Those chapters contain information about connection and functioning.



WARNING!

When the motor terminals U1, V1, W1 are connected to the inverter output with U, V, W respectively, the motor should rotate clockwise (Drive end side). It is NOT always correct to connect U, V, W of the converter with U, V, W of the motor. Check that the rotation is in the correct direction with the drive manufacturer.



WARNING!

The manufacturer of the plant/machinery is responsible for the correct installation of the motor. Signal and power cables must be shielded.



The motor must be connected as shown in the diagram supplied.

Follow the drive manufacturer's instructions and EMC guidelines.

Basic rules for connecting motors:

- Connecting conductors should be suitable for the type in use, as well as the rated voltages and currents.
- Connecting conductors should be of sufficient length, and be secure against twisting, pushing and pulling.
- Protective earth must be connected to the ground, according to local directives.

When using a plug connector, make sure that:

- Signal and power connectors are hand-tight to ensure proper electrical contact and that the connector is properly sealed and locked in position.

When connecting to the terminal box, also make sure that:

- Just enough insulation is removed from the ends of the wires to enable the wires to fit into the terminals/lugs.
- The size of the lugs matches the dimensions of the terminal board connections.
- The locking torque of the terminal boards' nuts must be respected.
- The protective earth is connected (for bigger sections, the ground connector is composed by 3 symmetrical wires).
- The inside of the terminal box is clean and free of wire cutting.
- Avoid the accidental fall of nuts or wire cutting inside the cable passage hole.
- The minimum separation for non-insulation current-carrying components is maintained.
- Check for protruding wire ends.
- Check that the minimum air gap between live parts is respected.
- Unused terminal boxes must be sealed, and the seals screwed down tightly to prevent dust and water entering.
- Sealing of the terminal box is done correctly, to ensure compliance with the degree of protection.

7.2 Power connection

Power connection is done by different types of connectors:

Power connector	BR series							
	03	05	07	V7	08	V8	09	V9
M23 8 poles	●	●	●					
MIL 4/6 poles		○	○	○				
Terminal board		○	○	●	●	●	●	●

● = Standard ○ = Optional

7.2.1 Power connection with connector M23 8 poles (standard)

POWER CONNECTOR		
Pin	Description	View from customer side
1	Motor phase U (A)	
4	Motor phase V (B)	
3	Motor phase W (C)	
⊕	Ground	
A	Brake + <i>(Optional)</i>	
B	Brake - <i>(Optional)</i>	
C		
D		

7.2.2 Power connection with connector MIL 4 poles (optional without brake)

POWER CONNECTOR		
Pin	Description	View from customer side
A	Motor phase U (A)	
B	Motor phase V (B)	
C	Motor phase W (C)	
D	Ground	

7.2.3 Power connection with connector MIL 6 poles (optional with brake)

POWER CONNECTOR		
Pin	Description	View from customer side
A	Motor phase U (A)	
B	Motor phase V (B)	
C	Motor phase W (C)	
D	Ground	
E	Brake +	
F	Brake -	

7.2.4 Power connection with terminal board (standard / optional)

POWER BOARD	
Marking	Description
A	Motor phase U (A)
B	Motor phase V (B)
C	Motor phase W (C)
	Ground

AUXILIARY BOARD	
Marking	Description
BR+	Brake + <i>(Optional)</i>
BR-	Brake - <i>(Optional)</i>
FAN	Fan <i>(Optional)</i>
FAN	Fan <i>(Optional)</i>
PT	Pt100 <i>(Optional)</i>
PT	Pt100 <i>(Optional)</i>
PT1000	Pt1000 <i>(Optional)</i>
PT1000	Pt1000 <i>(Optional)</i>
PTC	PTC <i>(Optional)</i>
PTC	PTC <i>(Optional)</i>

According to motor size, terminal box will have different dimensions.

Fixing pin of terminals will have different dimension according to the following table:

Motor type		Power pins	Auxiliary pins	Ground pins
BR03 (not available)		-	-	-
BR05 (optional)		M4	M4	M4
BR07 (optional)		M5	M5	M4
BRV7		M6	M4	M4
BR08		M6	M4	M4
BRV82	1000 rpm	M6	M4	M8
	2000 rpm	M6		
	3000 rpm	M6		
BRV84	1000 rpm	M6	M4	M8
	2000 rpm	M6		
	3000 rpm	M6		
BRV86	1000 rpm	M6	M4	M8
	2000 rpm	M6		
	3000 rpm	M8		
BRV88	1000 rpm	M6	M4	M8
	2000 rpm	M8		
	3000 rpm	M8		
BR092	1000 rpm	M8	M4	M8
	2000 rpm	M8		
	3000 rpm	M8		
BR094	1000 rpm	M8	M4	M8
	2000 rpm	M8		
	3000 rpm	M8		
BR096	1000 rpm	M8	M4	M8
	2000 rpm	M8		
	3000 rpm	M10		
BR098	1000 rpm	M8	M4	M8
	2000 rpm	M10		
	3000 rpm	M12		
BRV92	1000 rpm	M8	M4	M8
	2000 rpm	M8		
	2800 rpm	M8		
BRV94	1000 rpm	M8	M4	M10 + 3x M6
	2000 rpm	M10		
	2800 rpm	M12		
BRV96	1000 rpm	M8	M4	M10 + 3x M6
	2000 rpm	M10		
	2800 rpm	M12		
BRV98	1000 rpm	M10	M4	M10 + 3x M6
	2000 rpm	M12		
	2800 rpm	M16	M4	M12 + 3x M8

Tightening torque required changes for every kind of pin, according to the following table:

Pin dimension	Tightening torque [Nm]
M4	1.6
M5	2.5
M6	4
M8	8
M10	13
M12	20
M14	30
M16	40

WARNING!

Tighten cables on the terminal boards, respecting tightening torques of each type of pin.
Tolerance +0% / -10%



7.3 Signal connection

Signal connector	BR series							
	03	05	07	V7	08	V8	09	V9
Resolver M23 12P	●	●	●	●	●	●	●	●
Resolver MIL 19P		○	○	○	○	○	○	○
Encoder SinCos M23 17P		●	●	●	●	●	●	●
Encoder SinCos MIL 19P		○	○	○	○	○	○	○
Encoder Hiperface M23 12P		●	●	●	●	●	●	●
Encoder Hiperface MIL 19P		○	○	○	○	○	○	○
Encoder EnDat M23 17P		●	●	●	●	●	●	●
Encoder EnDat MIL 19P		○	○	○	○	○	○	○
Incremental encoder + Hall sensor M23 17P	◆	◆	◆	◆	◆	◆	◆	◆
Incremental encoder + Hall sensor MIL 19P	◆	◆	◆	◆	◆	◆	◆	◆

●= Standard ○= Optional ◆=Obsolete

7.3.1 Resolver with connector M23 – 12 poles (standard)

Motor series BR 3-5-7-8-9				View from customer side
Pin	Description	Feedback data		
1	SIN+	S4	Blue	
2	COS-	S3	Black	
3				
4				
5	SUPPLY-	R2	Yellow/White	
6				
7	SUPPLY+	R1	Red/White	
8	TP +		Thermal Protection +	
9	TP -		Thermal Protection -	
10	SIN-	S2	Yellow	
11	COS+	S1	Red	
12				



7.3.2 Resolver with connector MIL series – 19 poles (optional)

Motor series BR 5-7-8-9				View from customer side
Pin	Description	Feedback data		
A				
B			Ground	
C	COS+	S1	Red	
D	COS-	S3	Black	
E	SIN+	S4	Blue	
F	SIN-	S2	Yellow	
G				
H				
J				
K				
L				
M				
N				
P				
R				
S	TP -		Thermal Protection -	
T	TP +		Thermal Protection +	
U	SUPPLY +	R1	Red / White	
V	SUPPLY -	R2	Yellow / White	

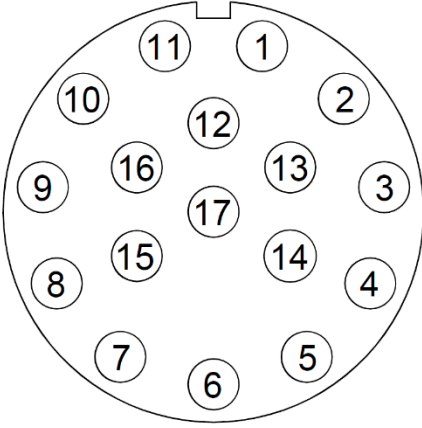
7.3.3 Encoder SinCos with connector M23 – 17 poles (standard)

Motor series BR 5-7-8-9			
Pin	Description	Feedback data	View from customer side
1	Up sensor	Blue	
2	R-	Black	
3	R+	Red	
4	0V sensor	White	
5	TP+	Thermal Protection	
6	TP-	Thermal Protection	
7	Supply Up	Brown / Green	
8	COS-	Violet	
9	COS+	Yellow	
10	Supply 0V	White / Green	
11			
12	B+	Blue / Black	
13	B-	Red / Black	
14	SIN+	Grey	
15	A+	Green / Black	
16	A-	Yellow / Black	
17	SIN-	Pink	

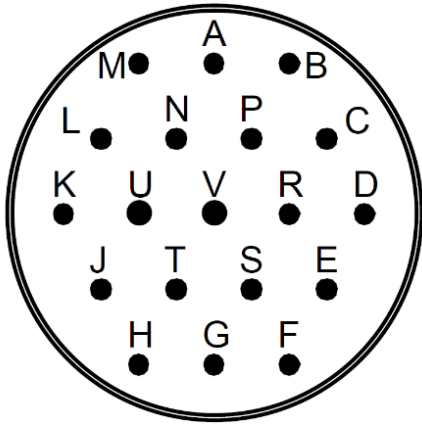

7.3.4 Encoder SinCos with connector MIL series – 19 poles (optional)

Motor series BR 5-7-8-9				
Pin	Description	Feedback data	View from customer side	
A	0 Vcc	0V		
B				Ground
C	COS+	D+		Yellow
D	COS-	D-		Violet
E	SIN+	C+		Grey
F	SIN-	C-		Pink
G				
H		B+		Blue / Black
J		B-		Red / Black
K		A-		Yellow / Black
L		A+		Green / Black
M		R+		Red
N		R-		Black
P	+Vcc	Up		Brown / Green
R				
S	TP -			Thermal Protection -
T	TP +			Thermal Protection +
U				
V				

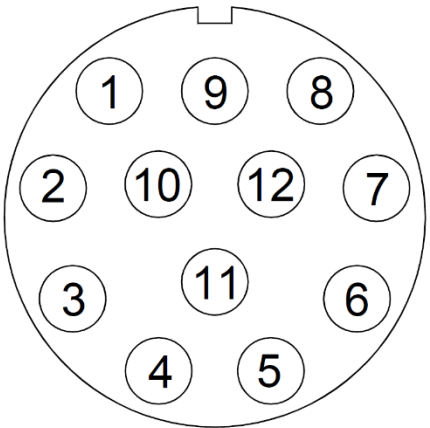
7.3.5 Encoder Hiperface with connector M23 – 12 poles (standard)

Motor series BR 5-7-8-9			
Pin	Description	Feedback data	View from customer side
1	TP +	Thermal Protection +	
2	TP -	Thermal Protection -	
3			
4	REFSIN	Brown	
5	REFCOS	Black	
6	DATA +	Grey or Yellow	
7	DATA -	Green or Purple	
8	SIN +	White	
9	COS +	Pink	
10	Us	Red	
11	GND	Blue	
12			

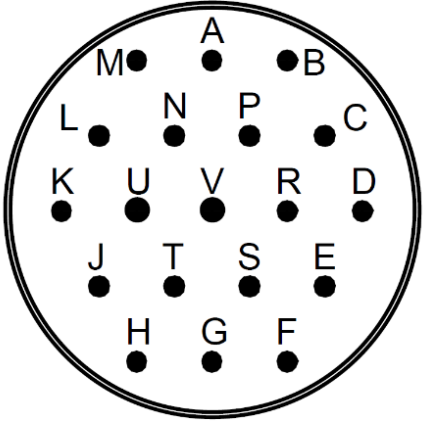

7.3.6 Encoder Hiperface with connector MIL series – 19 poles (optional)

Motor series BR 5-7-8-9			
Pin	Description	Feedback data	View from customer side
A	0V	Blue	
B		Ground	
C			
D			
E	DATA+	Grey or Yellow	
F	DATA-	Green or Purple	
G			
H	SIN+	White	
J	REFSIN	Brown	
K	REFCOS	Black	
L	COS+	Pink	
M			
N			
P	Us	Red	
R			
S	TP -	Thermal Protection -	
T	TP +	Thermal Protection +	
U			
V			

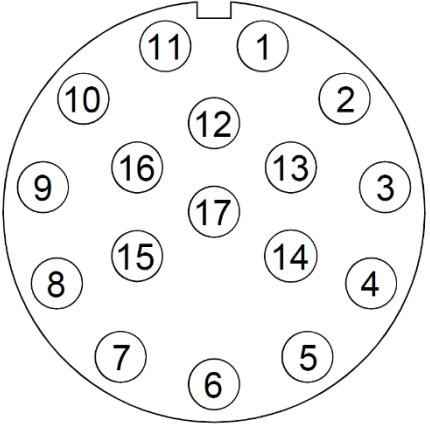
7.3.7 Encoder EnDat01 with connector M23 – 17 poles (standard)

Motori serie BR 5-7-8-9			
Pin	Description	Feedback data	View from customer side
1	Up sensor	Blue	
2			
3			
4	0V sensor	White	
5	TP+	Thermal Protection +	
6	TP-	Thermal Protection -	
7	Supply Up	Brown / Green	
8	CLOCK +	Violet	
9	CLOCK -	Yellow	
10	Supply 0V	White / Green	
11			
12	B+	Blue / Black	
13	B-	Red / Black	
14	DATA +	Grey	
15	A+	Green / Black	
16	A-	Yellow / Black	
17	DATA -	Pink	

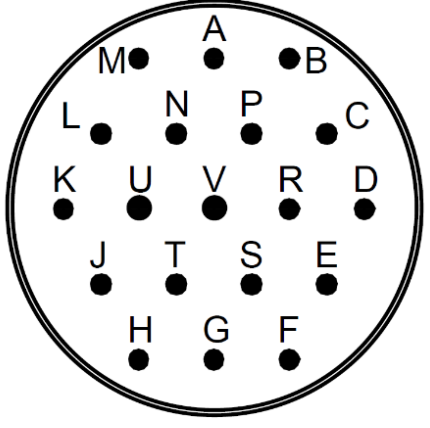

7.3.8 Encoder EnDat01 with connector MIL series – 19 poles (optional)

Motor series BR 5-7-8-9			
Pin	Description	Feedback data	View from customer side
A	0V	White / Green	
B		Ground	
C	CLOCK +	Violet	
D	CLOCK -	Yellow	
E	DATA +	Grey	
F	DATA -	Pink	
G			
H	B+	Blue / Black	
J	B-	Red / Black	
K	A-	Yellow / Black	
L	A+	Green / Black	
M			
N			
P	+Vcc	Brown / Green	
R			
S	TP -	Thermal Protection -	
T	TP +	Thermal Protection +	
U	Up sensor	Blue	
V	0V sensor	White	

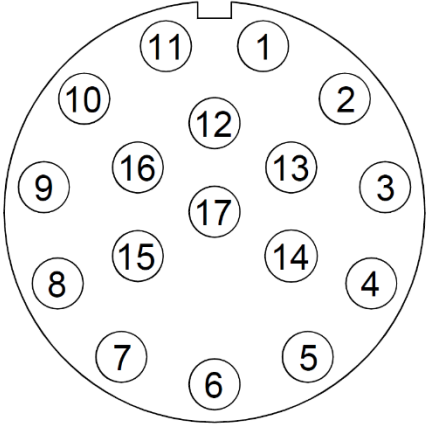
7.3.9 Encoder EnDat22 with connector M23 – 17 poles (standard)

Motor series BR 5-7-8-9			
Pin	Description	Feedback data	View from customer side
1	Up sensor	Blue	
2			
3			
4	0V sensor	White	
5	TP+	Thermal Protection	
6	TP-	Thermal Protection	
7	Supply Up	Brown / Green	
8	CLOCK +	Violet	
9	CLOCK -	Yellow	
10	Supply 0V	White / Green	
11			
12			
13			
14	DATA +	Grey	
15			
16			
17	DATA -	Pink	

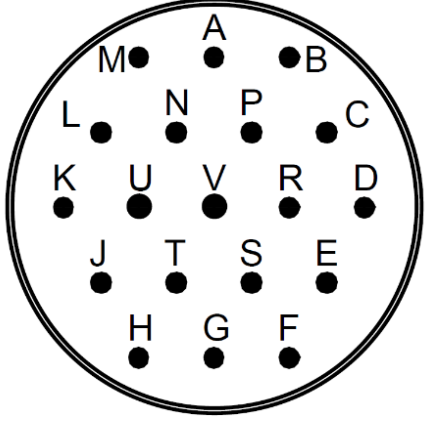
7.3.10 Encoder EnDat22 with connector MIL series – 19 poles (optional)

Motor series 5-7-8-9			
Pin	Description	Feedback data	View from customer side
A	0V	White / Green	
B		Ground	
C	CLOCK +	Violet	
D	CLOCK -	Yellow	
E	DATA +	Grey	
F	DATA -	Pink	
G			
H			
J			
K			
L			
M			
N			
P	Up	Brown / Green	
R			
S	TP -	Thermal Protection -	
T	TP +	Thermal Protection +	
U	Up sensor	Blue	
V	0V sensor	White	

7.3.11 Incremental encoder + Hall sensor and connector M23 – 17 poles (obsolete)

Motor series BR 3			
Pin	Description	Feedback data	View from customer side
1	W+	White	
2	Z-	Violet/Black	
3	Z+	Violet	
4	W-	White/Black	
5	TP+	Thermal Protection +	
6	TP-	Thermal Protection -	
7	+Vcc	Red	
8	U+	Brown	
9	U-	Brown/Black	
10	DC 0V	Black	
11			
12	B+	Green	
13	B-	Green/Black	
14	V+	Grey	
15	A-	Blue/Black	
16	A+	Blue	
17	V-	Grey/Black	

Motor series BR 5-7-8-9			
Pin	Description	Feedback data	View from customer side
1	U+	Brown	
2	Z-	Yellow/Black or Violet/Black	
3	Z+	Yellow or Violet	
4	U-	Brown/Black	
5	TP+	Thermal Protection +	
6	TP-	Thermal Protection -	
7	DC +5V	Red	
8	W+	White	
9	W-	White/Black	
10	DC 0V	Black	
11			
12	B+	Green	
13	B-	Green/Black	
14	V+	Grey	
15	A+	Blue	
16	A-	Blue/Black	
17	V-	Grey/Black	

7.3.12 Incremental encoder + Hall sensor and connector MIL series – 19 poles (obsolete)

Motor series BR 3			
Pin	Description	Feedback data	View from customer side
A	DC 0V	Black	
B		Ground	
C	W+	White	
D			
E	V+	Grey	
F			
G	U+	Brown	
H	B+	Green	
J	B-	Green/Black	
K	A+	Blue	
L	A-	Blue/Black	
M	Z+	Violet	
N	Z-	Violet/Black	
P	+Vcc	Red	
R	V-	Grey/Black	
S	TP-	Thermal Protection -	
T	TP+	Thermal Protection +	
U	U-	Brown/Black	
V	W-	White/Black	

Motor series BR 5-7-8-9			
Pin	Descrizione	Feedback data	View from customer side
A	DC 0V	Black	
B		Ground	
C	U+	Brown	
D			
E	V+	Grey	
F			
G	W+	White	
H	B+	Green	
J	B-	Green/Black	
K	A-	Blue/Black	
L	A+	Blue	
M	Z+	Yellow or Violet	
N	Z-	Yellow/Black or Violet/Black	
P	DC +5V	Red	
R	V-	Grey/Black	
S	TP-	Thermal Protection -	
T	TP+	Thermal Protection +	
U	W-	White/Black	
V	U-	Brown/Black	

7.4 Flying connectors (optional)

Different types of flying connectors are available, depending on motor configuration:

Flying connector	Available options		
Power	M23 8 poles	MIL 4 poles (without brake)	MIL 6 poles (with brake)
Signal	M23 12 poles	M23 17 poles	MIL 19 poles

Connections are the same described in chapters [Power connection \(7.2\)](#) and [Signal connection \(7.3\)](#).

7.4.1 Flying power connector M23 8 poles (optional)

M23 flying power connector must be chosen based on motor stall current (I_0) value, according to this table:

Stall current	Flying connector code
Up to 17 A _{rms}	BSTA078FR05420100000
Over 17 A _{rms}	BSTA078FR35590100000

Current carrying capacity of connectors change depending on the variation of ambient temperature and/or connector temperature itself.

It is recommended, where possible, the use of 2.5 - 4 mm² section.

WARNING!

Connector installed on the motor is SpeedTec ready.
If the flying connector is not SpeedTec but screw-type, O-ring must be removed from the connector.



7.4.1.1 Flying power connector 8 poles BSTA078FR05420100000

Type: SpeedTec
Conductors section: Power: 4 x (0.35 – 2.5 mm²), Auxiliary: 4 x (0.14 – 1.00 mm²)
Cable diameter: From 9.5 mm to 14.5 mm
Degree of protection: IP66 when connected
Junction method: Crimping

7.4.1.2 Flying power connector 8 poles BSTA078FR35590100000

Type: SpeedTec
Conductors section: Power: 4 x (2.5 – 4 mm²), Auxiliary: 4 x (0.14 – 1.00 mm²)
Cable diameter: From 14 mm to 17 mm
Degree of protection: IP66 when connected
Junction method: Crimping

7.4.1.3 Mounting instructions flying power connector BSTA078FR0542010000



intercontec
products





MONTAGEANLEITUNG¹⁾ ASSEMBLY INSTRUCTIONS¹⁾

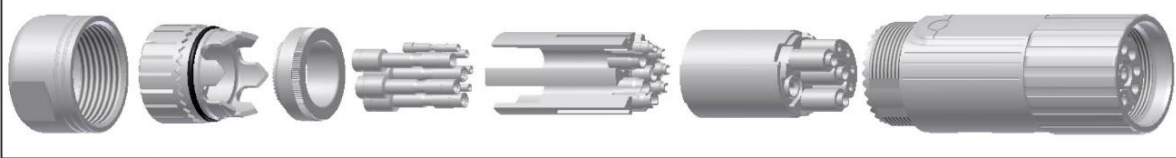

923 Stecker
8-polig, für Crimpkontakte

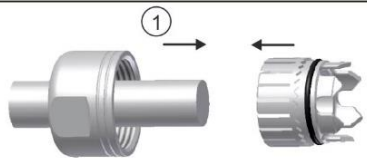
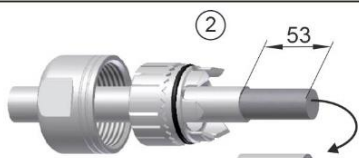
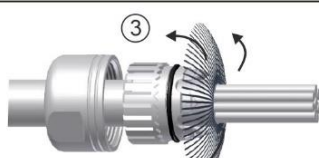
923 Plug
8-pin, crimp version

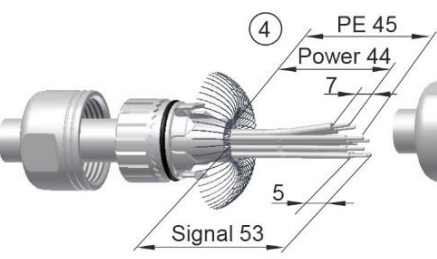

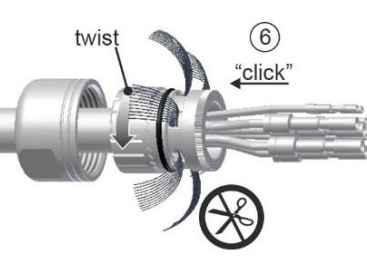
	a[mm ²]	Crimp Tool		Positioner	Colour
		No.:	No.:		
Power	0,35 - 2,5	C0.201.00		C0.004.00	blue
	2,5 - 4,0	- " -		- " -	blue
Signal	0,14 - 1,0	C0.201.00		C0.003.00	green
		digital crimp tool		tool settings: see	
		C0.236.00		crimp tool manual	

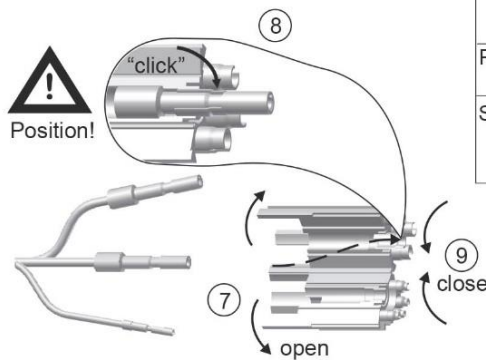
¹⁾Achtung: Unverbindlicher Verarbeitungshinweis.
Bedingt durch variierende Beschaffenheit von nicht INTERCONTEC-Komponenten können Abweichungen dieser Anleitung erforderlich sein. Geschultes Fachpersonal hat daher vor der Montage zu prüfen, ob eine abweichende Montage durchzuführen ist. Eine Haftung seitens Intercontec für prozessbedingte Folgekosten ist ausgeschlossen. Technische Änderungen vorbehalten.

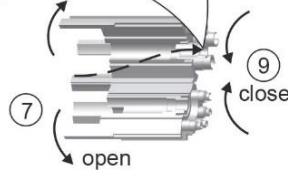
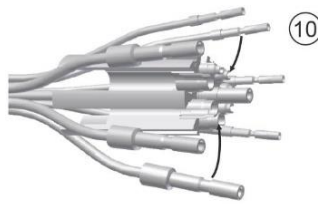
²⁾Attention, nonbinding processing instruction: Deviations from this instruction manual might be necessary depending on the properties and condition of non-INTERCONTEC components. Qualified personnel should check before assembling, if modification of the process is necessary. Intercontec is not liable for process-related damages. Subject to change without prior notice.

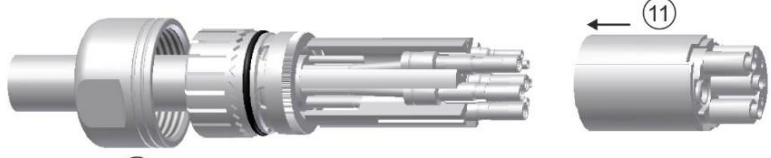
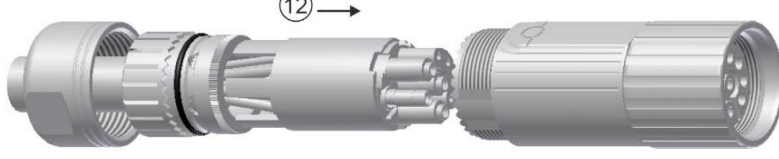
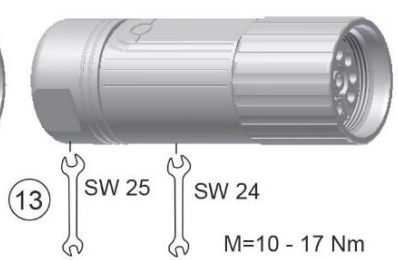
Y4-0011-000-000 erstellt: 15.01.2002/Fu; geändert: 21.09.2017/KC

7.4.1.4 Mounting instructions flying power connector BSTA078FR3559010000



intercontec
products



MONTAGEANLEITUNG¹⁾

ASSEMBLY INSTRUCTIONS¹⁾

923 Stecker
8-polig, für Crimpkontakte

923 Plug
8-pin, crimp version

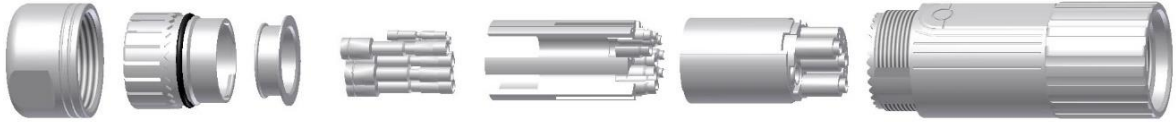

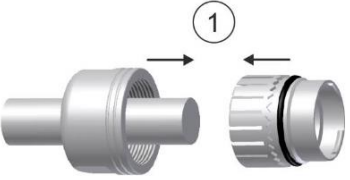
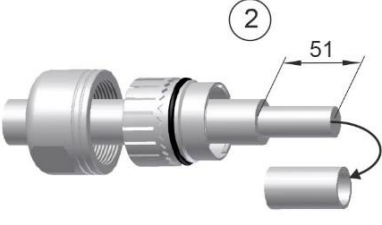
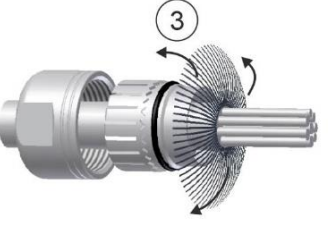
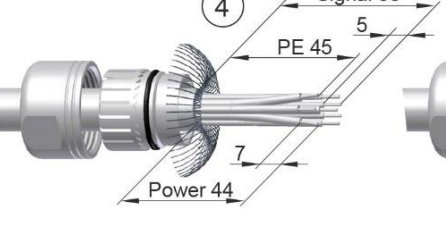
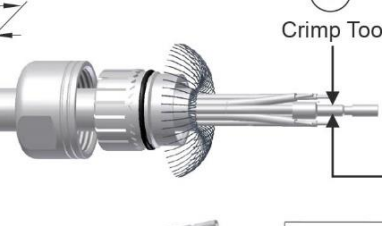
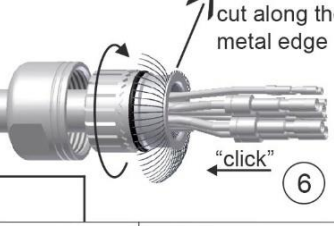
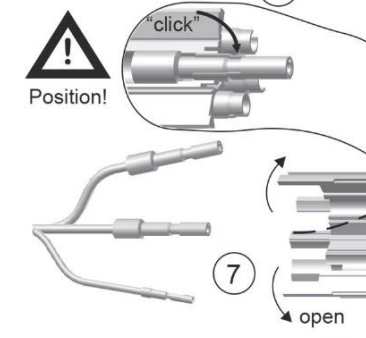
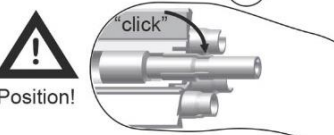
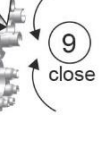
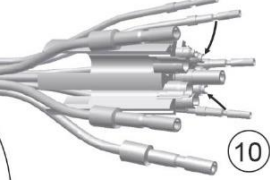
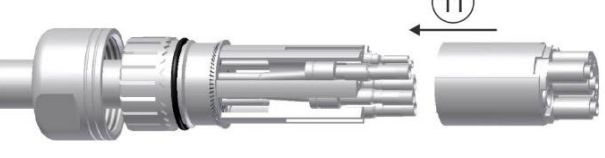
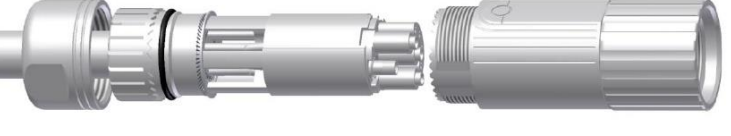
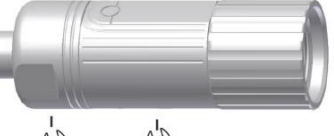
	a[mm²]	Crimp Tool No.:	Positioner No.:	Colour
Power	0,35 - 2,5	C0.201.00	C0.004.00	blue
	2,5 - 4,0	-	-	blue
Signal	0,14 - 1,0	C0.201.00	C0.003.00	green
		digital crimp tool	tool settings: see	
		C0.236.00	crimp tool manual	

13 SW 25 SW 24
M=10 - 17 Nm

¹⁾ Achtung: Unverbindlicher Verarbeitungshinweis.
Bedingt durch variierende Beschaffenheit von nicht INTERCONTEC-Komponenten können Abweichungen von dieser Anleitung erforderlich sein. Geschultes Fachpersonal hat daher vor der Montage zu prüfen, ob eine abweichende Montage durchzuführen ist. Eine Haftung seitens Intercontec für prozessbedingte Folgekosten ist ausgeschlossen. Technische Änderungen vorbehalten.
¹⁾ Attention, nonbinding processing instruction: Deviations from this instruction manual might be necessary depending on the properties and condition of non-INTERCONTEC components. Qualified personnel should check before assembling, if modification of the process is necessary. Intercontec is not liable for process-related damages. Subject to change without prior notice.

Y4-0038-000-000 erstellt: 22.09.2008/GS; geändert: 25.09.2017/Sp

7.4.2 Flying power connector 4/6 Poles MIL series (optional)

MIL power connectors are different for motors with or without the brake:

Motor type	Connector code
Without brake (4 poles)	MS3106PHM211810SA23
With brake (6 poles)	MS3106PHM211806SA23

7.4.2.1 Flying power connector MIL 4 poles MS3106PHM211810SA23

Type: Threaded
Conductors section: Power: 4 x (4 mm² - AWG12)
Cable diameter: Up to 17.5 mm
Degree of protection: IP65
Junction method: Soldering

7.4.2.2 Flying power connector MIL 6 poles MS3106PHM211806SA23

Type: Threaded
Conductors section: Power: 4 x (4 mm² - AWG12) ; Brake: 2 x (1.5 mm² - AWG16)
Cable diameter: Up to 17.5 mm
Degree of protection: IP65
Junction method: Soldering

7.4.3 Flying signal connector M23 12/17 poles (optional)

Flying M23 signal connector can be 12 or 17 poles, according to the type of transducer equipped:

Poles number	Connector code
12	ASTA021FS04400166000
17	ASTA035FS04400166000

WARNING!

Connector installed on the motor is SpeedTec ready.
If the flying connector is not SpeedTec but screw type, O-ring must be removed from the connector.



7.4.3.1 Flying signal connector M23 12 poles ASTA021FS04400166000

Type: SpeedTec
Conductors section: Signal: 12 x 1.50 mm²
Cable diameter: From 9 mm to 13.2 mm
Degree of protection: IP66 when connected
Junction method: Soldering

7.4.3.2 Flying signal connector M23 17 poles ASTA035FS04400166000

Type: SpeedTec
Conductors section: Signal: 17 x 1.50 mm²
Cable diameter: From 9 mm to 13.2 mm
Degree of protection: IP66 when connected
Junction method: Soldering

7.4.3.3 Mounting instructions flying signal connectors M23 12/17 poles



intercontec
products







MONTAGEANLEITUNG¹⁾

ASSEMBLY INSTRUCTIONS¹⁾

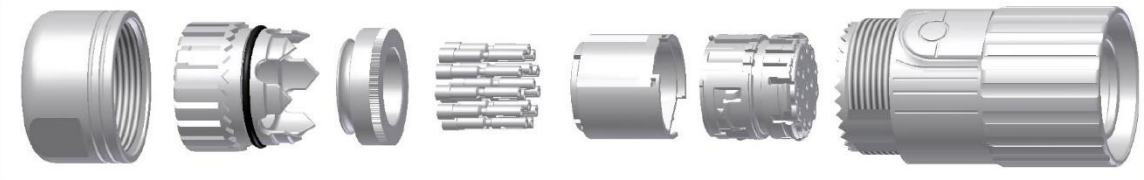

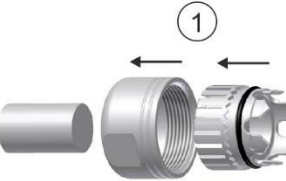
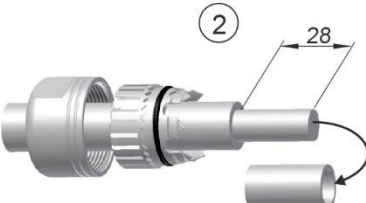
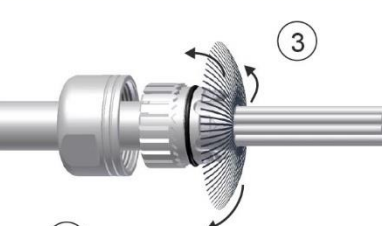



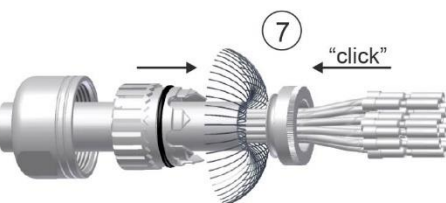

623 Stecker
für Crimpkontakte

623 Plug
crimp version

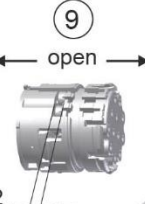

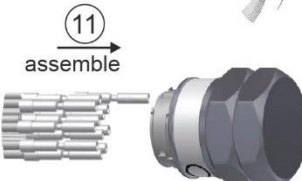
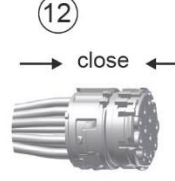
Crimpzange/ Crimp Tool	Einstellungen/ Tool Settings
C0.101.00	siehe Bedienungs- anleitung für Crimpzange/ see crimp tool manual
C0.235.00 (optional)	

¹⁾Achtung: Unverbindlicher Verarbeitungshinweis.
Bedingt durch variierende Beschaffenheit von nicht INTERCONTEC-Komponenten können Abweichungen dieser Anleitung erforderlich sein. Geschultes Fachpersonal hat daher vor der Montage zu prüfen, ob eine abweichende Montage durchzuführen ist. Eine Haftung seitens Intercontec für prozessbedingte Folgekosten ist ausgeschlossen. Technische Änderungen vorbehalten.

¹⁾Attention, nonbinding processing instruction: Deviations from this instruction manual might be necessary depending on the properties and condition of non-INTERCONTEC components. Qualified personnel should check before assembling, if modification of the process is necessary. Intercontec is not liable for process-related damages. Subject to change without prior notice.

Y4-0009-000-000 erstellt: 15.01.2002/Fu; geändert: 21.09.2017/KC

7.4.4 Flying signal connector 19P MIL series (optional)

Poles number	Connector code
19	62IN16PHM111419S4416

7.4.4.1 Flying signal connector MIL 19 poles 62IN16PHM111419S4416

Type: Bayonet
Conductors section: Signal: 19 x (0.5 mm² - AWG20)
Cable diameter: Up to 10.5 mm
Degree of protection: IP65
Junction method: Soldering

8. Transport and storage

8.1 Transport conditions

For transport, only use lifting eyes if they are provided with the motor.

WARNING!

Before lifting, check that the eyebolts are well threaded in and that the load is balanced.
Do not add any additional load, lifting tools are sized for the motor weight only.
Do not use lifting eyes if the temperature is lower than -20°C.



WARNING!

Do not manually lift the motor by grabbing the shaft. The plastic shaft cover could detach itself, causing the motor to fall with possible damage or injuries.



Motors leave the company in optimal conditions, after been checked and tested.
Inspect the motor carefully to make sure it has not undergone any damage during transport.
In case you notice any damage or anomalies, contact us as soon as possible and do not use the motor.

8.2 Storage conditions

To guarantee correct storage, ambient temperature must be between -20°C e +70°C.
If motors are stored, position it horizontally and make sure that they are kept in a dry, dust-free and without vibrations environment.
Rotate the motor shaft for some revolutions every 2-3 months.
Measure the insulation resistance before putting the motors into operation for the first time and verify that it is at least 2MΩ. Dry out the windings if the insulation resistance is $\leq 2M\Omega$.

9. Installation

9.1 Mounting

WARNING!

Motors are designed exclusively for the installation in industrial environments. Different installation conditions are allowed only if the necessary safety precautions are applied.

Read carefully all the present manual before any kind of operation.

Every mounting operation must be executed by qualified personnel, equipped properly for the kind of operation.



Make sure that the feet and flange are firmly fixed.

For mounting with flange IM B5 (IM 3001), the mount must be stable and solid to prevent vibration and bending.

For mounting the motor with foot IM B5 (IM 3001) and IM B35 (IM 2001), the motor must be attached to a flat, stable and solid base, to prevent vibration transfer.

WARNING!

The motor must be fitted in such a way that heat loss can be adequately dissipated. Do not impede free circulation of air around servo-ventilated motors or through forced-ventilated motors.

Flange opposite side must NOT be thermally insulated, because it is necessary for heat dissipation.



For larger motor (size BR 86, 88, 96, 98) a mounting IM B35 (IM2001) is recommended, or else you should use a back support in order to avoid bending or deformations of the flange/shaft (this support shouldn't be rigid, it should be provided with springs or rubber).

The push that the support must exert is 50% of total motor weight.

WARNING!

In case of vertical installation with the shaft end facing upwards, it is imperative to ensure that no liquid (water, machine coolant, etc.) can penetrate the top bearing.

In case of direct coupling in oil bath, make sure that the oil seal is equipped along with its spring.



WARNING!

In case of direct coupling with gears or gearbox, take the utmost care to make a precise alignment between the motor shaft and the driven-shaft and between the coupling flanges.

Any vibrations or irregular rotations are indications of inaccurate alignments which will cause strong vibrations, operating malfunctions or damage to rotor shaft.



In case of coupling with drive belts install the motor with the shaft perfectly parallel and aligned to that of the pulley to avoid axial thrust on the supports. The tensioning of the belts in no case must it exceed the maximum applicable load. Make sure that the axial load does not exceed 20% of the maximum radial load indicated at the nominal speed.

WARNING!

Excessive tension of the belts can cause rapid wear of the bearings and may cause shaft breakages.



Move command elements only with a suitable device.

WARNING!

The fitting and removal of drive components (e.g. coupling disc, belt pulley, gearwheel, etc.) must be carried out with suitable equipment (e.g. the transmission device must be preheated or fixed using the threaded hole on the motor shaft end with the special tool).
Before keying on the transmission gear remove the rust-preventive paint from the rotor shaft and from the key using alcohol or an appropriate solvent (it is important that the solvent does not enter inside of the bearings).



Grease the end of the shaft and the key before keying the transmission gear.

The general safety precautions regarding prevention of contact with the drive components must be observed.

WARNING!

Never strike or exert pressure on the end of the shaft when installing the motor.



Check insulating resistance before commissioning, and when you suspect humidity in the windings.

Insulating resistance must be over 100 MΩ at 25°C (measured with 500 Vdc or 1000 Vdc).

This value is halved every 20°C of ambient temperature increase.

If the value is lower than this value, the windings shall be oven dried.

Oven temperature shall be 90°C for 12-16 hours, and afterwards 105°C for 6-8 hours.

ATTENZIONE!

Use of damaged or unsuitable components can lead to damage to people or things.



Motor flange must be fixed directly to the machine using suitable screws.

Respect correct tightening torque, using proper tools.

9.2 Commissioning

Before putting the motor into operation, check that:

- The rotor can turn freely (supply the brake if necessary).
- The drive components are correctly installed.
- All electrical connections and connector match the specifications and are properly tightened.
- The protective earth connection is properly connected.
- All auxiliary equipment (e.g. separately driven fan, brake, etc.) is correctly functioning.
- Appropriate safety measures have been taken to prevent contact with live or moving parts.

WARNING!

After installing the motor, check that the brake (if installed) works properly. The brake is designed to carry out just a limited number of emergency braking operations. It must not be used as a regular service brake.

**ATTENZIONE!**

Always use safety devices, even during testing operations.

**WARNING!**

Under certain conditions, such as with long power cables or high frequencies, industrial variable speed drives may cause voltage peaks, which are dangerous to the motor's windings. Check, with proper equipment, that over-voltages do not surpass critical values.



The cause of this phenomenon is external to the motor.

If needed, we recommended to add suitable filters to reduce over-voltages $\frac{dV}{dt}$, and the use of symmetrical shielded cables.

WARNING!

This list may be incomplete.
Further verifications may be necessary.



9.3 Balance

Standard motors are dynamically balanced with half key, at no load and uncoupled.

Pay attention to balance when fitting the drive element.

Transmission elements such as pulleys, couplings, etc. must be dynamically balanced with "half key" before installations.

WARNING!

Secure feather key before testing the motor without drive elements.

Always verify the vibrations of the whole motor + transmission system, before starting up the system for good. In case of dangerous resonances, balance the system again or modify the support structure of the motor if necessary.

**ATTENZIONE!**

If motors are used in operations with frequent rotation inversion, it is unadvisable to use shaft key, because it can cause strain on the shaft and even shaft damage. It is recommended to use a shaft without key.



10. Operating conditions

10.1 Environmental conditions

WARNING!

Use in explosive areas, (e.g. Ex or ATEX), is strictly forbidden unless the motors are intentionally supplied to you for this purpose after an agreement with Brusatori.



The motors are rated for ambient temperature between -20°C and +40°C for motors without brake, or between +2 and +40 °C for motors with brake.

The motors are rated for installation at altitudes of ≤1000 m above sea level.

The motors are rated for environments with humidity under 90% (no condensation).

For different ambient conditions, power and torque can differ from the values provided.

WARNING!

As motors contain permanent magnets, avoid proximity to people who have internal medical devices (e.g. pacemaker) or to material that can be damaged by magnetic fields. It is necessary to give proper warning signs and install barriers to ensure safety.



WARNING!

Motors can reach high noise levels while operating. Take precautions to ensure safety and avoid hearing damage.



10.2 Derating of the motor in function of temperature / altitude

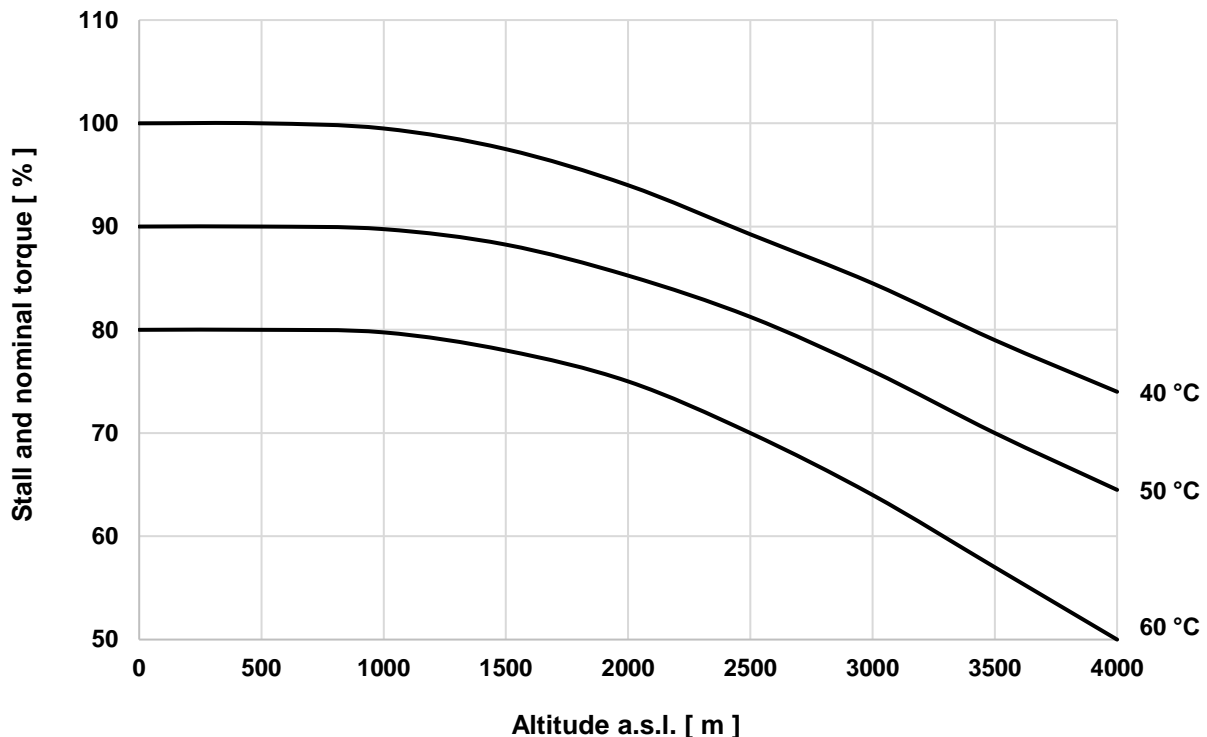

10.3 Safety information

Observe the instructions on the nameplate for mounting and degree of protection, and check that they are suitable for the installation side.

WARNING!

The surfaces of motors can reach temperatures higher than 100°C, even after powering it off. For this reason, no temperature-sensitive items such as wires or electronic components should be in contact with these surfaces.

If necessary, take precautions to prevent contact.



WARNING!

Disconnect the motor before operating on it.

After shutting off the drive, wait 5 minutes before starting to operate again, to be sure that DC bus is de-energized and therefore not dangerous.



WARNING!

The motor case must be earthed, and the windings must be discharged immediately after each measurement to avoid any risk of electric shock.



ATTENZIONE!

During operation, keep your distance from the dangerous zone.

Unauthorized personnel's access must be limited.



11. Maintenance

11.1 Maintenance instructions

WARNING!

Before carrying out any work on the motor, and especially before uncovering live parts, be sure to:

- Disconnect the motor from the power supply.
- Secure against reconnection.
- Check that equipment is not connected.
- Check ground connection.
- Cover or screen off all live adjacent parts.

Remember to disconnect any supplementary or auxiliary circuits as well as the main circuits. The above actions may only be reversed when all repair work has been completed and the motor has been completely reassembled.



WARNING!

The system must be disconnected from the power supply before any work is carried out. Since the motor contains permanent magnets, a voltage is generated at the motor terminals when the motor is in rotation.



Standard motors have ball bearings pre-lubricated for their life, maintenance free. Check their temperature and vibrations every 2000 hours of operation. We recommend that the bearings are replaced after approximately 20000 hours of operation or at most every three years. The bearings must be suitable for operations at temperatures between -20°C and +130°C.

For motors equipped with greasers for the periodic lubrication of the bearings, it is necessary to comply with the lubrication intervals suggested by the manufacturer.

Ambient temperature, operating speed and the type of lubricant oil used can affect substantially the frequency of the interventions. For further details, please refer to our technical department.

For motors directly coupled with an oil exhaust gearbox, check every 500 hours the oil exhaust hole. Replace the radial shaft seal in case of oil leakage.

For spare parts please specify in detail all data of the motor/equipment they refer to, along with possible options requested when placing the order. Consult exploded pictures for correct choice of requested components. Consult exploded drawings for the correct identification of the components.

WARNING!

Keep this manual, along with safety and operating instructions in a safe place!

If not directly authorized by the manufacturer, any repair performed by users will invalidate any manufacturer's liability for the conformity of the motor.

We recommend the repair work to be carried out by our Service Center.



Unprotected surfaces (flanges and shaft ends) must be treated with anticorrosive products.
 Cleaning the motor can cause damage if it is done incorrectly.
 Only proper products can be used.
 Avoid contact between products and oil seals or gaskets to avoid damage.

11.2 Troubleshooting



Note:

This list cannot be considered complete. If you have any doubts consult our technical office.

PROBLEM	POSSIBLE CAUSE	POSSIBLE SOLUTION
Motor does not start	No power supply	Check power supply, Check drive connections
	No brake release	Check brake connection or if there are any faults
	Encoder/resolver malfunction	Check wirings and connections, look for any encoder/resolver faults
Motor runs slowly or not as intended	Inverter malfunctioning, wrong connection or wiring	Confront that displayed and nominal values corresponds, check the inverter settings and connection
	Encoder/resolver malfunction	Check wirings and connections, look for any encoder/resolver faults
Motor overheats	Abnormal operating values, cooling problems	Verify that the fan works correctly
	Thermal protection malfunctioning	Check that thermal protection works correctly
	Overload, abnormal power supplied, inverter fault	Confront nominal values and values displayed
	No brake release	Check that the brake works correctly
Brake does not work	Brake fault, wrong brake connection/wiring	Check connections, check if the brake is damaged
Vibrations	Abnormal balance, worn out bearings, fixing screws loose	Balance the motor correctly, tighten loosen screws, replace worn out bearings
High noise level	Foreign bodies inside the motor, wrong inverter settings	Verify the presence of any foreign bodies inside the motor, check inverter settings
Other problems not listed here	Instructions not followed or accidental fault	Immediately contact our technical office

12. Disposal

Refer to the nature of the material and the rules in force regarding decommissioning and disposal of the electrical equipment, to limit the impact on the environment and avoid ecological damage.

Pay utmost attention to permanent magnets during their disposal.

13. Certifications

13.1 RoHS directive

All motors in the present manual comply with Directive 2011/65/EU (RoHS Directive) and following Delegated Directives, on limitation of hazardous substances.

13.2 EMC directive

Electrical motors are not covered by Directive 2014/30/EU (EMC Directive) on Electromagnetic Compatibility. All motors in the present manual comply with EMC Directive if said motors are equipped with electronic components, because the installed devices have been verified compliant to said Directive.

13.3 EU Declaration of Conformity

Most recent version of the Declaration of Conformity can be found on Brusatori website.

13.4 Quality management system ISO 9001: 2015

Most recent version of the document can be found on Brusatori website.

13.5 UL/CSA Certificate of compliance (optional)

Most recent version of UL and CSA certificates of compliance can be found on Brusatori website.

Notes

14. Contacts

Name	Brusatori Srl
Address	Via Antonio Meucci 5/7, 20012 Cuggiono (MI) – Italy
Phone	+39 0225068401
Fax	+39 0225060140
Website	www.brusatori.eu
E-mail	info@brusatori.eu



Via Meucci 5/7
20012 Cuggiono (MI) Italy
Tel: (0039) 02-25068401
Fax: (0039) 02-25060140
Web: <http://www.brusatori.eu/>
Mail: info@brusatori.eu

BR